

FACILITIES FOR INTERSTATE ACCESS

Regulations, Rates and Charges Applicable to  
Facilities for Interstate Access and Miscellaneous Services

provided by

BRIGHTSPEED LOCAL OPERATING COMPANIES

to Interstate Customers

All material in this Service Guide is new

Services herein are provided by means of wire, fiber optics, radio or any other suitable technology or a combination thereof.

The geographical applications are as indicated following the names of the issuing carriers on Title Page 2.

This Brightspeed Local Operating Companies Interstate Service Guide No. 2 replaces in its entirety the rates, terms and conditions previously contained in CenturyLink Operating Companies Interstate Service Guide No. 2.

FACILITIES FOR INTERSTATE ACCESS

ISSUING CARRIERS

CenturyTel of Southern Alabama  
 1120 South Tryon St, Ste. 700  
 Charlotte, NC 28203

CenturyTel of Central Missouri  
 1120 South Tryon St, Ste. 700  
 Charlotte, NC 28203

Exchanges included in CenturyTel of Southern Alabama:

Abbeville	Andalusia	Ariton
Banks	Brantley	Brundidge
Cilo	Columbia	Daleville
Dothan	Dozier	Echo
Elba	Enterprise	Forest Home
Gantt	Geneva	Georgiana
Greenville	Hartford	Headland
Kinston	Louisville	Luverne
McKenzie	Midland City	New Brockton
Newton	Newville	Opp
Ozark	Red Level	Samson
Scottsboro	Section	Skyline
Slocomb	Wickburg	

Exchanges included in CenturyTel of Central Missouri:

Ashland	Ava	Centralia
Clark	Columbia	Crane
Hallsville	Mansfield	Rocheport
Sturgeon		

## FACILITIES FOR INTERSTATE ACCESS

TABLE OF CONTENTS  
ALPHABETICAL LISTING

	<u>Section</u>	<u>Page</u>
Application of Service Guide	1.	1-1
General Regulations	2.	2-1
Miscellaneous Services	6.	6-1
Optical Networking	20.	20-1
Ordering Options for FIA	3.	3-1
Special Access	5.	5-1
Special Facilities Routing of FIA	9.	9-1
Specialized FIA or Arrangements	7.	7-1

## FACILITIES FOR INTERSTATE ACCESS

## TABLE OF CONTENTS

	<u>Page</u>
Table of Contents	1
Concurring Carriers	3
Connecting Carriers	3
Other Participating Carriers	3
Explanation of Symbols	3
Explanation of Abbreviations	3
Reference to Other Tariffs	7
Reference to NECA Tariffs	7
Reference to Technical Publications	7
1. <u>APPLICATION OF SERVICE GUIDE</u>	1-1
2. <u>GENERAL REGULATIONS</u>	2-1
3. <u>ORDERING OPTIONS FOR FIA</u>	3-1
4. <u>RESERVED FOR FUTURE USE</u>	4-1
5. <u>SPECIAL ACCESS</u>	5-1
6. <u>MISCELLANEOUS SERVICES</u>	6-1
7. <u>SPECIALIZED FIA OR ARRANGEMENTS</u>	7-1
8. <u>RESERVED FOR FUTURE USE</u>	8-1
9. <u>SPECIAL FACILITIES ROUTING OF FIA</u>	9-1
10. <u>RESERVED FOR FUTURE USE</u>	10-1
11. <u>RESERVED FOR FUTURE USE</u>	11-1
12. <u>RESERVED FOR FUTURE USE</u>	12-1
13. <u>RESERVED FOR FUTURE USE</u>	13-1
14. <u>RESERVED FOR FUTURE USE</u>	14-1
15. <u>RESERVED FOR FUTURE USE</u>	15-1
16. <u>RESERVED FOR FUTURE USE</u>	16-1
17. <u>RESERVED FOR FUTURE USE</u>	17-1
18. <u>RESERVED FOR FUTURE USE</u>	18-1
19. <u>RESERVED FOR FUTURE USE</u>	19-1
20. <u>OPTICAL NETWORKING</u>	20-1

## FACILITIES FOR INTERSTATE ACCESS

## CONCURRING CARRIERS

No Concurring Carriers

## CONNECTING CARRIERS

No Connecting Carriers

## OTHER PARTICIPATING CARRIERS

No Other Participating Carriers

## EXPLANATION OF SYMBOLS

- (C) - To signify changed regulation
- (D) - To signify discontinued rate or regulation
- (I) - To signify increase
- (N) - To signify new rate or regulation
- (R) - To signify reduction
- (S) - To signify reissued matter
- (T) - To signify a change in text but no change in rate or regulation
- (M) - To signify matter relocated without change
- (Z) - To signify a correction

## EXPLANATION OF ABBREVIATIONS

- AAM - Assumed Access Minutes
- ac - alternating current
- ACAT - Additional Cooperative Acceptance Testing
- ACD - Automatic Call Distributor
- ACNA - Access Customer Name Abbreviation
- ACTL - Access Customer Terminal Location
- ADM - Add/Drop Multiplexing
- AIOD - Automatic Identification of Outward Dialed
- AM - Access Minutes
- ANI - Automatic Number Identification
- ARD - Automatic Ringdown
- ASG - Access Services Group
- ASR - Access Service Request
- AST - Automatic Scheduled Testing
- ATM - Asynchronous Transfer Mode
- AT&TC - American Telephone and Telegraph Communications, Inc.

## FACILITIES FOR INTERSTATE ACCESS

## EXPLANATION OF ABBREVIATIONS (Cont'd)

BDS	-	Business Data Services
BHMC	-	Busy Hour Minutes of Capacity
BP	-	Billing Percentage
BSA	-	Basic Serving Arrangement
BSE	-	Basic Service Element
CAC	-	Carrier Access Code
CCS	-	Centum Call-Seconds
CCSA	-	Common Control Switching Arrangement(s)
CDL	-	Customer Designated Location
CDM	-	Call Days in Month
CFA	-	Connecting Facility Assignment
CIC	-	Carrier Identification Code
CIP	-	Carrier Identification Parameter
CMF	-	Chargeable Minimum Factor
COMPS	-	Central Office Maintenance Planning System
Cont'd	-	Continued
CST	-	Cooperative Scheduled Testing
CSU	-	Circuit Switching Unit
CTOC	-	CenturyTel Operating Company
DA	-	Digital Data Access
DAM	-	Distance in Airline Miles
dB	-	Decibel
dBm	-	Decibels below one milliwatt
dBmO	-	Transmission Level Referred to the Zero Transmission Level Point
dBmCO	-	Decibel Reference Noise C-Message Weighted O
dBv	-	Decibels Referred to One Volt
dc	-	direct current
DDS	-	Digital Data Service
DTMF	-	Dual Tone Multifrequency
DX	-	Duplex
ECCKT	-	Exchange Carrier Circuit ID
ELEPL	-	Equal Level Echo Path Loss
E&M	-	The Receive and Transmit Leads of a Signaling System
EML	-	Expected Measured Loss
EPL	-	Echo Path Loss
ERL	-	Echo Return Loss
EUCT	-	End User Channel Termination
f	-	frequency
FCC	-	Federal Communications Commission
FCO	-	Foreign Central Office Service
FIA	-	Facilities for Interstate Access
FNPA	-	Foreign Numbering Plan Area
GSEC	-	General Services and Equipment Code
HC	-	High Capacity
HNPA	-	Home Numbering Plan Area
Hz	-	Hertz
IA	-	Interface Arrangement
IC	-	Interexchange Carrier
ICB	-	Individual Case Basis

## FACILITIES FOR INTERSTATE ACCESS

## EXPLANATION OF ABBREVIATIONS (Cont'd)

IDDD	-	International Direct Distance Dialing
ILP	-	Initial Liability Period
IP	-	Interconnection Point
kbps	-	kilobits per second
kHz	-	kilohertz
LATA	-	Local Access and Transport Area
LEC	-	Local Exchange Carrier
Ma	-	Milliamperes
Mbps	-	Megabits per second
MHz	-	Megahertz
MJU	-	Multi-Junction Unit
MRC	-	Monthly Recurring Charge
MST	-	Manual Scheduled Testing
MTL	-	Maximum Termination Liability
NA	-	Not Available
NANP	-	North American Numbering Plan
NECA	-	National Exchange Carrier Association
NPA	-	Numbering Plan Area
NRC	-	Nonrecurring Charge
NST	-	Nonscheduled Testing
NXX	-	Three Digit Central Office Code
OC-n	-	Optical Carrier Rate
OPS	-	Off-Premises Station
PBX	-	Private Branch Exchange
PCM	-	Pulse Code Modulation
POT	-	Point of Termination
PSTN	-	Public Switched Telephone Network
PVU	-	Percent VoIP Usage
RMC	-	Recurring Monthly Charge
rms	-	root-mean-square
SCFA	-	Secondary Connecting Facility Assignment
SF	-	Single Frequency
SONET	-	Synchronous Optical Network
SRL	-	Singing Return Loss
STR	-	Switched Transport Rate
TDCF	-	Total Day Conversion Factor
TDM	-	Time Division Multiplexing
TLP	-	Transmission Level Point
TV	-	Television
UL	-	Under Utilization Liability
VG	-	Voice Grade
V&H	-	Vertical & Horizontal
VoIP	-	Voice over Internet Protocol
WATS	-	Wide Area Telecommunications Service

## FACILITIES FOR INTERSTATE ACCESS

EXPLANATION OF ABBREVIATIONS (Cont'd)  
STATE ABBREVIATIONS

AL - Alabama	MT - Montana
AK - Alaska	MTC - The Micronesian Telecommunications Corporation
AR - Arkansas	NE - Nebraska
AZ - Arizona	NC - North Carolina
CA - California	ND - North Dakota
CO - Colorado	NH - New Hampshire
CT - Connecticut	NJ - New Jersey
DE - Delaware	NM - New Mexico
FL - Florida	NV - Nevada
GA - Georgia	NY - New York
HI - Hawaii	OH - Ohio
IA - Iowa	OK - Oklahoma
ID - Idaho	OR - Oregon
IL - Illinois	PA - Pennsylvania
IN - Indiana	RI - Rhode Island
KS - Kansas	SC - South Carolina
KY - Kentucky	SD - South Dakota
LA - Louisiana	TN - Tennessee
MA - Massachusetts	TX - Texas
MD - Maryland	UT - Utah
ME - Maine	VA - Virginia
MI - Michigan	VT - Vermont
MN - Minnesota	WA - Washington
MO - Missouri	WI - Wisconsin
MS - Mississippi	WV - West Virginia
	WY - Wyoming



Effective: October 4, 2022

Original Page 7

## FACILITIES FOR INTERSTATE ACCESS

## REFERENCE TO OTHER TARIFFS

Whenever reference is made in this service guide to other tariffs of Brightspeed, the reference is to the tariffs in force as of the effective date of this service guide, and to amendments thereto and successive issues thereof.

## REFERENCE TO NECA TARIFFS

NECA Tariff FCC No. 4  
NECA Tariff FCC No. 5

## REFERENCE TO TECHNICAL PUBLICATIONS

NECA Technical Reference Publication AS No. 1 - Issued March, 1984; entire issue  
Addendum - Issued March, 1987

GTE Technical Interface Reference Manual, Issue 2 - Issued August, 1984, Revised December 1985,  
August 1986 and October 1988; Sections 3300, 5107, 6000, 6103 and 7000

American National Standards Institute Publication ANSI T1.102, Issued 1993  
American National Standards Institute Publication ANSI T1.105, Issued 1995

Underwriters Laboratory Publication UL 94, Issued 1990

AT&T Technical Reference Publication 41014 - Issued February, 1978; entire issue

GTE Service Corporation Telephone Operations - Traffic Grade of Service Standards, Issued April, 1985;  
entire issue

Bellcore Technical Reference Publication	
TR-TSV-000905, Issue 1, August, 1989	GR-253-CORE, Issue 2, April, 1996
TR-NWT-000499, Issue 4, November, 1991	GR-1400-CORE, Issue 1, March, 1994
TR-NWT-000063, Issue 4, July, 1991	GR-1374-CORE, Issue 1, March, 1994
TR-TSY-000191, Issue 1, May, 1986	GR-1149-CORE, Issue 1, October, 1995
TR-TSY-000487, Issue 1, July, 1989	Available February, 1997
TR-NPL-000320, Issue 1, April, 1988	

Multiple Exchange Carrier Access Billing (MECAB) Guidelines - Issued June, 1994.

Multiple Exchange Carrier Ordering and Design (MECOD) Guidelines - Issued May, 1994.

Internet Engineering Task Force (IETF) and Internet Architecture Board (IAB) documentation on Internet protocol standards.

Available from the Federal Communications Commission's commercial contractor.  
Available from Testmark Labs, 3050 Harrodsburg Rd., Lexington, Kentucky 40503.  
Available from Underwriters Laboratory, Inc. Attention: Publications, 333 Pflingsten Rd., Northbrook, Illinois 60062.

## FACILITIES FOR INTERSTATE ACCESS

## REFERENCE TO TECHNICAL PUBLICATIONS (Cont'd)

The following technical publications are referenced in this service guide and may be obtained from Telcordia Technologies, Inc., Customer Services, One Ericsson Drive., RRC 4A-1060, Piscataway, NJ 08854-4156.

Available from American National Standards Institute, 1430 Broadway, New York, NY 10018.

Available from the IETF, Corporation for National Research Initiatives (CNRI), Suite 100, Preston White Drive, Reston, VA 22091 and in electronic form at Internet locations <http://www.isi.edu/iab/> and <http://www.ietf.cnri.reston.va.us/>

Section 6.4(E)(8) NCS Manual 3-1-1 "Telecommunications Service Priority (TSP) System for National Security Emergency Preparedness (NSEP) Service User Manual", dated July 9, 1990.

Section 6.4(F)(4) NCS Handbook 3-1-2 "Telecommunications Service Priority (TSP) System for National Security Emergency Preparedness (NSEP) Service Vendor Handbook", dated July 9, 1990.

47 C.F.R. FCC Rules and Regulations, Part 15.109

Issued: April 17, 2001 10-01-95

Available 10-01-95

Society of Motion Picture and Television Engineers (SMPTE) 259M-1997 standards

Issued: April 17, 2001 09-25-97

Network Equipment – Building System (NEBS), SR-3580, Issue 1,

Issued: April 17, 2001 November 1995

Available: April 2000

GR-1089-CORE, Issue 2, Issued: April 17, 2001 December 1997, February 1999

Available: April 2000

Available from Government Printing Office, Superintendent of Documentation, Document Control Branch, 941 North Capitol Street, N.E., Washington, DC 20401.

Available from SMPTE, 595 W. Hartsdale Ave, White Plains, NY 10607.

Available from Telcordia Technologies, Inc., 8 Corporate Place, PYA 3A-184, Piscataway, NJ 08854-4156

The following publications are referenced in this service guide and may be obtained from the American National Standards Institute (ANSI), 11 West 42nd Street, New York, New York 10036.

ANSI / IEEE X3.802.3

Issue Date March 2002

ANSI / IEEE X3.802.3u

Issue Date June 1995

ANSI / IEEE X3.802.3z

Issue Date June 1998

FACILITIES FOR INTERSTATE ACCESS

REFERENCE TO TECHNICAL PUBLICATIONS (Cont'd)

The following publication is referenced in this service guide and may be obtained from the Internet Engineering Task Force (IETF), c/o Association Management Solutions, LLC, 48377 Fremont Blvd., Suite 117, Fremont, California 94538.

IETF RFC 4090

Issue Date May 2005

The following publication is referenced in this service guide and may be obtained from the International Communications Union, Place des Nations, 1211 Geneva 20, Switzerland.

ITU-TY.1731

Issue Date February 2008

## FACILITIES FOR INTERSTATE ACCESS

1. APPLICATION OF SERVICE GUIDE

- 1.1 This service guide contains regulations, rates and charges applicable to Special Access, Universal Service Fund and Optical Networking Access Service or, in combination, as Facilities for Interstate Access, hereinafter referred to as FIA, provided by the issuing carriers of this service guide, hereinafter referred to as the Company to customers. This service guide further provides for Ancillary and Miscellaneous Services. This service guide does not apply to other services offered by the Company.

Pursuant to the Commission's Rules at Section 69.4(c), 69.5(d), 69.104(1), 69.116, 69.117, 69.603(c), and 69.603(d), regulations concerning administration and billing of Universal Service Fund, rates and charges for these carrier's carrier elements are contained in Section 8 of the National Exchange Carrier Association, Inc. Tariff FCC No. 5. The National Exchange Carrier Association, Inc. will bill and collect Universal Service Fund charges on behalf of the Company.

- 1.2 Regulations, rates and charges as specified in this service guide apply to FIA and shall not serve as a substitute for IC tariff offerings of services to end users. The provision of such FIA by the Company as set forth in this service guide does not constitute a joint undertaking with an IC for the furnishing of any service.

## FACILITIES FOR INTERSTATE ACCESS

2. GENERAL REGULATIONS2.1 Undertaking of the Company2.1.1 Scope

- (A) The Company does not undertake to transmit calls or offer a telecommunications service under this service guide.
- (B) The Company shall be responsible only for the installation, operation, and maintenance of the services which it provides.
- (C) The Company will, for maintenance purposes, test its FIA only to the extent necessary to detect and/or clear troubles. Testing beyond normal parameters will be done as described in Section 6.
- (D) FIA are provided twenty-four hours daily, seven days per week.

2.1.2 Limitations

- (A) The customer may not assign or transfer the use of FIA provided under this service guide except that, where there is no interruption of use or relocation of the FIA, such assignment or transfer may be made to:
  - another customer, whether an individual, partnership, association or corporation, provided the assignee or transferee assumes all outstanding indebtedness for such FIA, and the unexpired portion of the minimum period and the termination liability applicable to such FIA, if any; or
  - a court appointed receiver, trustee or other person acting pursuant to law in bankruptcy, receivership, reorganization, insolvency, liquidation or other similar proceedings, provided the assignee or transferee assumes the unexpired portion of the minimum period and the termination liability applicable to such FIA, if any.

In all cases of assignment or transfer, the written acknowledgment of the Company is required prior to such assignment or transfer which acknowledgment shall be made within 15 days from the receipt of notification. All regulations and conditions contained in this service guide shall apply to such assignee or transferee.

The assignment or transfer of FIA does not relieve or discharge the assignor or transferor from remaining jointly or severally liable with the assignee or transferee for any obligations existing at the time of the assignment or transfer.

- (B) The emergency provisioning and restoration of FIA shall be in accordance with Part 64, Subpart D, Paragraph 64.401, of the FCC's Rules and Regulations, which specifies the priority system for such activities. Section 6.4 describes the service arrangement.

## FACILITIES FOR INTERSTATE ACCESS

2. GENERAL REGULATIONS (Cont'd)2.1 Undertaking of the Company (Cont'd)2.1.2 Limitations (Cont'd)

- (C) The Company does not warrant that its facilities and services meet standards other than those in this service guide.

2.1.3 Liability

- (A) The Company's liability, if any, for willful misconduct is not limited by this service guide. With respect to any other claim or suit by a customer for damages associated with the installation, provision, termination, maintenance, repair or restoration of FIA, and subject to the provisions of (B) and (C), the Company's liability, if any, shall not exceed an amount equal to the proportionate charge for the FIA for the period during which the provision of FIA was affected. This liability for damages shall be in addition to any amounts that may otherwise be due the customer under this service guide as a credit allowance for a provision of FIA interruption.

- (B) The Company shall not be liable for any act or omission of any other carrier or customer providing a portion of a service, nor shall the Company, for its own act or omission, hold liable any other carrier or customer providing a portion of a service.

- (C) The Company shall be indemnified, defended and held harmless by the customer against any claim, loss or damage arising from the use of FIA offered under this service guide. The foregoing indemnity shall issue on the customer separately, each being responsible for its own acts and omissions, involving:

- Claims for libel, slander, invasion of privacy, or infringement of copyright arising from any communications;
- Claims for patent infringement arising from combining or using the FIA furnished by the Company in connection with facilities or equipment furnished by the customer; or
- All other claims arising out of any act or omission of the customer in the course of using FIA provided pursuant to this service guide.

- (D) The Company does not guarantee or make any warranty with respect to its FIA when used in an explosive atmosphere. The Company shall be indemnified, defended and held harmless by the customer from any and all claims by any person relating to the FIA so provided. The foregoing indemnity shall issue on the customer separately, each being responsible for its own acts and omissions.

- (E) Except in the case of willful misconduct, under no circumstances whatever shall the Company be liable for indirect, incidental, special or consequential damages; and this disclaimer shall be effective notwithstanding any other provisions hereof.

## FACILITIES FOR INTERSTATE ACCESS

2. GENERAL REGULATIONS (Cont'd)2.1 Undertaking of the Company (Cont'd)2.1.3 Liability (Cont'd)

- (F) No license under patents is granted by the Company to the customer or shall be implied or arise by estoppel in the customer's favor with respect to any circuit, apparatus, system or method used by the customer in connection with FIA provided under this service guide. With respect to claims of patent infringement made by third persons, the Company will defend, indemnify, protect and save harmless the customer from and against all claims arising out of the use by the customer of FIA provided under this service guide.
- (G) The Company's failure to provide or maintain FIA under this service guide shall be excused by labor difficulties, governmental orders, civil commotions, acts of God and other circumstances beyond the Company's reasonable control, subject to the interruption allowance provisions.
- (H) The Company shall reimburse the customer for damages to premises or equipment of the customer resulting from the provision of FIA by the Company on such premises, or by the installation or removal thereof, caused by the negligence or willful act of the Company.

2.1.4 Provision of FIA

- (A) The Company, to the extent that such FIA are or can be made available with reasonable effort, and after provisions have been made for the Company's local service, will provide to the customer, upon reasonable notice, FIA offered in other applicable sections of this service guide at rates and charges specified therein.
- (B) FIA provided to a customer under this service guide may be connected directly to customer facilities and/or may be connected to access facilities of another telephone company or companies in the joint provision of interstate access.

2.1.5 Installation and Termination of FIA

FIA provided under this service guide (A) will include any entrance cable or drop wiring and wire or intrabuilding cable to that point where provision is made for termination of the Company's outside distribution network facilities at a suitable location inside a customer designated location, and (B) will be installed by the Company to such point of termination.

2.1.6 Maintenance of FIA

The FIA provided under this service guide shall be maintained by the Company. The customer or others may not rearrange, move, disconnect, remove or attempt to repair any FIA provided by the Company, other than by connection or disconnection to any interface means used, except with the written consent of the Company.

## FACILITIES FOR INTERSTATE ACCESS

2. GENERAL REGULATIONS (Cont'd)2.1 Undertaking of the Company (Cont'd)2.1.7 Changes and Substitutions

Except as provided for equipment and systems subject to Part 68 of the FCC Rules and Regulations in 47 C.F.R. Paragraph 68.110 (b), the Company may, where such action is reasonably required in the operation of its business, substitute, change, or rearrange any telephone plant used in providing FIA under this service guide, change minimum network protection criteria, change operating or maintenance characteristics of facilities, or change operations or procedures of the Company. In case of any such substitution, change or rearrangement, the facility parameters will be within generally accepted standards. The Company shall not be responsible if any such substitution, change or rearrangement renders any customer furnished services obsolete or requires modification or alteration thereof or otherwise affects their use or performance. If such substitution, change, or rearrangement materially affects the operating characteristics or technical parameters of the FIA, as originally ordered by the customer, the Company will notify the customer in writing prior to making such substitution, change or rearrangement. Notification will be given as follows:

- Should a major change occur, the Company shall notify the customer at least one year in advance. A major change is described as any change in telephone plant which will affect the technical parameters of the interface.
- Should a minor change occur, the Company shall notify the customer at least thirty days in advance. A minor change is described as any change in telephone plant which will not affect the technical parameters of the interface.

The Company will work cooperatively with the customer relative to the redesign and implementation required by the change in operating characteristics.

2.1.8 Discontinuance and Refusal of FIA

- (A) Unless the provisions of 2.2.1(B) or 2.5.1 apply, if the customer fails to comply with the provisions of 2.1.6, 2.3.1, and 2.4.1(D), including any payments to be made by it on the dates or at the times herein specified, and fails within thirty (30) days after written notice, by mail or by email if the customer is billed electronically or consents to receiving electronic notification, from the Company to a person designated by the customer to correct such noncompliance, the Company may discontinue the provision of the FIA to the noncomplying customer. In case of such discontinuance, all applicable charges shall become due.
- (B) If the customer repeatedly fails to comply with the provisions of this service guide in connection with the provision of a FIA or group of FIA, and fails to correct such course of action after notice as in (A), the Company may refuse applications for additional FIA to the noncomplying customer until the course of action is corrected.



## FACILITIES FOR INTERSTATE ACCESS

2. GENERAL REGULATIONS (Cont'd)2.1 Undertaking of the Company (Cont'd)2.1.9 Preemption of FIA

In certain instances, i.e., when spare facilities and/or equipment are not available, it may be necessary to preempt existing services to provision or restore National Security Emergency Preparedness (NSEP) Services. If, in its best judgment, the Telephone Company deems it necessary to preempt, then the Telephone Company will ensure that:

- (A) A sufficient number of public switched services are available for public use if preemption of such services is necessary to provision or restore NSEP Service.
- (B) The service(s) preempted have a lower or do not contain NSEP assigned priority levels.
- (C) A reasonable effort is made to notify the preempted service customer of the action to be taken.
- (D) A credit allowance for any preempted service shall be made in accordance with the provisions in Section 2.4.4(A).

## FACILITIES FOR INTERSTATE ACCESS

2. GENERAL REGULATIONS (Cont'd)2.2 Use2.2.1 Interference or Impairment

- (A) The characteristics and methods of operation of any circuits, facilities or equipment provided by other than the Telephone Company, including customer transmission equipment and facilities used with EIS, and associated with the FIA provided under this service guide shall not interfere with or impair service over any facilities of the Telephone Company, its connecting and concurring carriers, or other telephone companies involved in its services, cause damage to their plant, impair the privacy of any communications carried over their facilities or create hazards to their employees or to the public.
- (B) Except as provided for equipment or systems subject to Part 68 of the FCC Rules and Regulations in 47 C.F.R. Paragraph 68.108, if such characteristics or methods of operation are not in accordance with (A), the Telephone Company will, where practicable, notify the customer, as appropriate, that temporary discontinuance of the use of FIA may be required; however, where prior notice is not practicable, nothing contained herein shall be deemed to preclude the Telephone Company's right to temporarily discontinue forthwith the use of FIA if such action is reasonable in the circumstances. In case of such temporary discontinuance the customer will be promptly notified and afforded the opportunity to correct the condition which gave rise to the temporary discontinuance. During such period of temporary discontinuance, allowance for interruption of FIA as in 2.4.4 is not applicable.

2.2.2 Unlawful Use of FIA

The FIA are furnished subject to the condition that they will not be used for an unlawful purpose. FIA will be discontinued if any law enforcement agency, acting within its apparent jurisdiction, advises in writing that such FIA are being used in violation of law. The Telephone Company will refuse to furnish FIA when it has reasonable grounds to believe that such FIA will be used in violation of law.

## FACILITIES FOR INTERSTATE ACCESS

2. GENERAL REGULATIONS (Cont'd)2.3 Obligation of the Customer2.3.1 Damages

The customer shall reimburse the Telephone Company for damages to the Telephone Company facilities utilized to provide FIA under this service guide caused by:

- the negligence or willful act of the customer, or
- resulting from the customer's improper use of the Telephone Company facilities, or
- due to malfunction of any facilities or equipment provided by other than the Telephone Company.

Nothing in the foregoing provision shall be interpreted to hold one customer liable for another customer's actions. The Telephone Company will, upon reimbursement for damages, cooperate with the customer in prosecuting a claim against the person causing such damage and the customer shall be subrogated to the right of recovery by the Telephone Company for the damages to the extent of such payment. The amount of reimbursement shall be the actual cost of repair to the damaged facilities including labor costs as specified in 6.2(G).

2.3.2 Theft

The customer shall reimburse the Telephone Company for any loss through theft of facilities, apparatus, or equipment utilized to provide FIA under this service guide at the customer designated location or at the end user's premises. The amount of reimbursement shall be the actual cost for replacement of facilities, apparatus, or equipment lost, plus labor costs as specified in 6.2(G).

2.3.3 Equipment Space and Power

The customer shall furnish or arrange to have furnished to the Telephone Company at no charge, equipment space and electrical power required by the Telephone Company to provide FIA under this service guide at the points of termination of such FIA. The equipment space provided shall meet industry standard environmental conditions. The selection of ac or dc power shall be mutually agreed to by the customer and the Telephone Company. The customer shall also make necessary arrangements in order that the Telephone Company will have access to such spaces at reasonable times for installing, repairing or removing facilities of the Telephone Company.

2.3.4 Reserved For Future Use2.3.5 Availability for Testing

The FIA provided under this service guide shall be available to the Telephone Company at times mutually agreed upon in order to permit the Telephone Company to make tests and adjustments appropriate for maintaining the FIA in satisfactory operating condition. Such tests and adjustments shall be completed within a reasonable time. No credit will be allowed for any interruptions involved during such tests and adjustments.

## FACILITIES FOR INTERSTATE ACCESS

2. GENERAL REGULATIONS (Cont'd)2.3 Obligation of the Customer (Cont'd)2.3.6 Balance

All signals for transmission over the FIA provided under this service guide shall be delivered by the customer balanced to ground except for ground start and duplex (DX), McCulloh-loop (alarm system) type signaling, and dc telegraph transmission at speeds of 75 baud or less.

2.3.7 Design of Customer Services

Subject to the provisions of 2.1.7, the customer shall be solely responsible at its expense for the overall design of its services. The customer shall be responsible at its own expense, for any redesigning or rearrangement of its services which may be required because of changes in FIA, operations or procedures of the Company, minimum network protection criteria or operating or maintenance characteristics of the FIA.

2.3.8 References to Company

The customer may advise its end users that certain FIA are provided by the Company in connection with the service the customer furnishes to its end user; however, the customer shall not represent that the Company jointly participates in the customer's services.

## FACILITIES FOR INTERSTATE ACCESS

2. GENERAL REGULATIONS (Cont'd)2.3 Obligation of the Customer (Cont'd)2.3.9 Claims and Demands for Damages

- (A) With respect to claims of patent infringement made by third persons, the customer shall defend, indemnify, protect and save harmless the Company from and against all claims arising out of the combining with, or use in connection with, the FIA provided under this service guide, any circuit, apparatus, system or method provided by the customer, the IC or its end users.
- (B) The customer shall defend, indemnify and save harmless the Company from and against suits, claims, and demands by third persons arising out of the construction, installation, operation, maintenance, or removal of the customer's circuits, facilities, or equipment connected to the Company's FIA provided under this service guide including, without limitation, Workmen's Compensation claims, actions for infringement of copyright and/or unauthorized use of program material, libel and slander actions based on the content of communications transmitted over the customer's circuits, facilities or equipment, and proceedings to recover taxes, fines, or penalties for failure of the customer to obtain or maintain in effect any necessary certificates, permits, licenses or other authority to acquire or operate the FIA provided under this service guide; provided, however, the foregoing indemnification shall not apply to suits, claims, and demands to recover damages for damage to property, death, or personal injury unless such suits, claims or demands are based on the tortuous conduct of the customer, its officers, agents or employees.

2.3.10 Coordination With Respect to Network Contingencies

The customer shall, in cooperation with the Company, coordinate in planning the actions to be taken to maintain maximum network capability following natural or man-made disasters which affect telecommunications services.

## FACILITIES FOR INTERSTATE ACCESS

2. GENERAL REGULATIONS (Cont'd)2.4 Payment Arrangements and Credit Allowances2.4.1 Payment of Charges and Deposits

- (A) The Company may, in order to safeguard its interests, require a customer, which has a proven history of late payments to the Company or does not have established credit, to make a deposit prior to or at any time after the provision of the FIA to the customer to be held by the Company as a guarantee of the payment of rates and charges. No such deposit will be required of a customer which is a successor of a company which has established credit and has no history of late payments to the Company.

A deposit may not exceed the actual or estimated rates and charges for the FIA for a two month period. The fact that a deposit has been made in no way relieves the customer from complying with the Company's regulations as to the prompt payment of bills.

At such time as the provision of the FIA to the customer is terminated, the amount of the deposit will be credited to the customer's account and any credit balance which may remain will be refunded. After the customer has established a one year prompt payment record, such a deposit will be refunded or credited to the customer account at any time prior to the termination of the provision of the FIA to the customer.

In case of a cash deposit, for the period the deposit is held by the Company, the customer will receive interest at the same percentage rate as that set forth in (D)(2)(a) or in (D)(2)(b), whichever is lower. The rate will be compounded daily for the number of days from the date the customer deposit is received by the Telephone Company to and including the date such deposit is credited to the customer's account or the date the deposit is refunded by the Telephone Company. Should a deposit be credited to the customer's account, as indicated above, no interest will accrue on the deposit from the date such deposit is credited to the customer's account.

- (B) Reserved for future use.

## FACILITIES FOR INTERSTATE ACCESS

2. GENERAL REGULATIONS (Cont'd)2.4 Payment Arrangements and Credit Allowances (Cont'd)2.4.1 Payment of Charges and Deposits (Cont'd)

(C) The Company shall bill FIA services on a current basis for (a) all charges incurred, (b) applicable taxes, and (c) credits due the customer.

- Miscellaneous services shall be billed in arrears.
- Special Access and Multiplexing elements shall be billed in advance except for the charges and credits associated with the initial or final bills. The initial bill will also include charges for the actual period of service up to, but not including, the bill date. The unused portion of the FIA already billed will be credited on the final bill.

The customer will receive its bill in: 1) a paper format, 2) via electronic data transfer or 3) on-line bill image. Such bills are due when rendered regardless of the media utilized. Adjustments for the quantities of FIA established or discontinued in any billing period beyond the minimum period in 2.4.2 will be prorated to the number of days based on a 30 day month. The Company will, upon request and if available, furnish such detailed information as may reasonably be required for verification of any bill.

(D) All bills to the customer are due 31 days (payment date) after the bill date or by the next bill date (i.e., same date in the following month as the bill date), whichever is the shortest interval. In the event the customer does not remit payment in immediately available funds by the payment date, the FIA may be discontinued as specified in 2.1.8.

(1) If such payment date would cause payment to be due on a Saturday, Sunday or Holiday (i.e., New Year's Day, Independence Day, Labor Day, Thanksgiving Day, Christmas Day, the second Tuesday in November and a day when Washington's Birthday, Memorial Day or Columbus Day is legally observed), payment for such bills will be due from the customer as follows:

- If such payment date falls on a Saturday or on a Holiday which is observed on Tuesday, Wednesday, Thursday or Friday, the payment date shall be the last non-Holiday day preceding such Saturday or Holiday.
- If such payment date falls on a Sunday or on a Holiday which is observed on a Monday, the payment date shall be the first non-Holiday day following such Sunday or Holiday.

(2) Further, if any portion of the payment is received by the Company after the payment date as set forth in a. preceding, or if any portion of the payment is received by the Company in funds which are not immediately available to the Company, then a late payment penalty shall be due to the Company. The late payment penalty shall be the portion of the payment not received by the payment date times a late factor. The late factor shall be the lesser of:

- (a) The highest interest rate (in decimal value) which may be levied by law for commercial transactions, compounded daily for the number of days from the payment date to and including the date that the customer actually makes the payment to the Company, or
- (b) 0.000407 per day, compounded daily for the number of days from the payment date to and including the date that the customer actually makes the payment to the Company.

## FACILITIES FOR INTERSTATE ACCESS

2. GENERAL REGULATIONS (Cont'd)2.4 Payment Arrangements and Credit Allowances (Cont'd)2.4.1 Payment of Charges and Deposits (Cont'd)

## (D) (Cont'd)

- (3) In the event of a billing dispute, the customer must submit a documented claim for the disputed amount.
- If the claim is received within 6 months of the payment due date, and the customer has paid the total billed amount, any interest credits due the customer upon resolution of the dispute shall be calculated from the date of overpayment.
  - If the claim is received more than 6 months from the payment due date, any interest credits due the customer upon resolution of the dispute shall be calculated from the later of the date the claim was received or the date of overpayment.

A credit will be granted to the customer for both the disputed amount paid and an amount equal to the percentage rate in (2).

The Company will assess or credit late payment charges on disputed amounts to the customer as follows:

- If resolved in favor of the Company and the customer has paid the disputed amount on or before the payment due date, no late payment charges will apply.
- If resolved in favor of the Company and the customer has withheld the disputed amount, any payments withheld pending settlement of the dispute shall be subject to the late payment charge in (2).
- If resolved in favor of the customer and the customer has withheld the disputed amount, the customer shall be credited for each month or portion thereof that the late payment charge in (2) may have been applied. In the event the customer has paid the late payment charge, a credit will be granted to the customer for both the late payment charge paid on disputed amount and an amount equal to the percentage rate in (2).



## FACILITIES FOR INTERSTATE ACCESS

2. GENERAL REGULATIONS (Cont'd)2.4 Payment Arrangements and Credit Allowances (Cont'd)2.4.2 Minimum Periods

- (A) The minimum periods for which FIA are provided and which rates and charges are applicable are in 3.2.4.
- (B) The minimum periods for which FIA are provided and which rates and charges are applicable for Specialized FIA or Arrangements provided on an Individual Case Basis, as in Section 7 are established with the individual case filing.
- (C) For discontinuance of FIA with a one month minimum period, all applicable charges for the one month period will apply. In instances where the minimum period is greater than one month, however, the charge will be the lesser of the Company's non-recoverable costs less the net salvage value for the discontinued service of the minimum period charges.
- (D) The minimum periods for Optical Networking Services are provided and which rates and charges are applicable are in Section 20.

## FACILITIES FOR INTERSTATE ACCESS

## 2. GENERAL REGULATIONS (Cont'd)

## 2.4 Payment Arrangements and Credit Allowances (Cont'd)

## 2.4.3 Cancellation of an ASR

Provisions for the cancellation of an ASR are in 3.2.6.

## 2.4.4 Credit Allowance for FIA Interruptions

## (A) General

A FIA is interrupted when it becomes unusable to the customer because of a failure of a component used to furnish FIA under this service guide, or when the service is preempted as a result of invoking NSEP Treatment or when the application of protective controls interrupt all transmission paths as set forth in 4.2.9 following. An interruption period starts when Company personnel become aware that the FIA is inoperative.

The credit allowance(s) for an interruption or for a series of interruptions will be computed based upon the billing method which applies to the service being credited. In no case will the credit allowance for service interruptions exceed the applicable charges, less any discounts, for the billing period during which the interruption occurred.

A credit allowance for any FIA service will apply for the period specified as follows:

- (1) For Special Access services other than Program Audio and Multiplexing services a credit allowance will be made for an interruption period of 30 minutes or more. The allowance will be calculated at the rate of 1/1440 of the monthly charge for the portion of the FIA affected, for each 30 minutes or major fraction thereof that the interruption continues. A major fraction is considered to be sixteen minutes or more beyond the 30 minute period.
- (2) For Program Audio Special Access services, a credit allowance will be made for an interruption of 30 seconds or more. Two or more such interruptions occurring during a period of 5 consecutive minutes shall be considered as one interruption. The allowance will be calculated as follows:
  - (a) For Program Audio Service provided at monthly rates, the credit will be at the rate of 1/8640 of the monthly service rate.
  - (b) For Program Audio Service provided at daily rates, the credit will be at the rate of 1/288 of the daily rate.
- (3) Except as noted, all Special Access Services will be eligible for a credit allowance for each occurrence of a service interruption period greater than 30 minutes. The maximum credit allowance will be \$200.00 for each out of service condition within the Company's facilities and will not exceed the monthly charge for the interrupted service. The credit allowance will not be applied more than once per calendar month. This credit allowance is applicable in all jurisdictions. The credit allowance is in addition to the credit allowance in 2.4.4(A)(1) and 2.4.4(A)(2). A credit allowance will not be extended in accordance with conditions in 2.1.3(G) and 2.4.4(B) for repair of Company owned facilities.

The exception to this credit allowance is Part-time Program Audio Service in 5.2.3.

## FACILITIES FOR INTERSTATE ACCESS

2. GENERAL REGULATIONS (Cont'd)2.4 Payment Arrangements and Credit Allowances (Cont'd)2.4.4 Credit Allowance for FIA Interruptions (Cont'd)(A) General (Cont'd)

- (3) An out of service credit will apply for the following Optical Networking rate elements, where applicable, should the service be interrupted due to the Company's system's failure to switch to protected electronics and/or facilities within one (1) second in those locations connected to the Company surveillance system unless such interruptions are a result of conditions outside the Company's control:

- Ring Connect
- LAN-wide Premium Transport
- Ring-per-mile Transport
- ON-net Banded Optical Transport provisioned via ring topology
- Custom Connect configured via a ring topology

Credit will be predicated on information provided by the Company's and the customer's network surveillance systems associated with this service arrangement. The Company and the customer shall each have the opportunity to perform an annual inspection of the other party's network surveillance system to confirm its accuracy. The out-of-service credit will be calculated based on the monthly rate element charges of that portion of the inter-office network rendered inoperative. A maximum limit of one months recurring charge per rate element will be allotted for an interruption or series of interruptions within any one billing period.

The credit allowance for all other Optical Networking access services will be as shown in 2.4.4(1) and (3).

- (4) For Ethernet Virtual Private Line (EVPL) service, no credit allowance shall be allowed for an interruption of less than one minute. If covered facilities fail for one minute or more, the customer will be credited 100% of the monthly recurring charges associated with the interrupted facility.

## FACILITIES FOR INTERSTATE ACCESS

2. GENERAL REGULATIONS (Cont'd)2.4 Payment Arrangements and Credit Allowances (Cont'd)2.4.4 Credit Allowance for FIA Interruptions (Cont'd)(B) When Credit Allowance Does Not Apply

No credit allowance will be made for:

- (1) Interruptions caused by the negligence of the customer.
- (2) Interruptions of a FIA due to the failure of equipment or systems provided by the customer or others.
- (3) Interruptions of a FIA during any period in which the Company is not afforded access to the premises where the FIA is terminated.
- (4) Interruptions of a FIA during an agreed upon period when the customer has released a FIA to the Company for maintenance purposes, to make rearrangements, or for the implementation of an ASR for a change in the FIA. Should the maintenance, rearrangement, or ASR implementation interruption period extend beyond the agreed upon period, credit allowance will apply.
- (5) Interruptions of a FIA which continue because of the failure of the customer to authorize replacement of any element of Special Construction, as set forth in Brightspeed Local Operating Companies Tariff F.C.C. No. 5. The period for which no credit allowance is made begins on the seventh day after the Company's written notification to the customer of the need for such replacement and ends on the day after receipt of the customer's written authorization for such replacement.
- (6) Periods when the customer elects not to release the FIA for testing and/or repair and continues to use it on an impaired basis.
- (7) An interruption or a group of interruptions, resulting from a common cause, for amounts less than one dollar.

(C) Use of an Alternative Service Provided by the Company

Should the customer elect to use an alternative service provided by the Company during the period that a FIA is interrupted, the customer must pay the Company's rates and charges for the alternative service used.

(D) Temporary Surrender of a FIA

In certain instances, the customer may be requested to surrender a FIA for purposes other than maintenance, testing or activity relating to an ASR. If the customer consents, or in the instance of preemption under NSEP Treatment as set forth in Section 2.1.9 preceding, a credit allowance will be granted. The credit allowance will be determined in accordance with 2.4.4(A) preceding.

## FACILITIES FOR INTERSTATE ACCESS

2. GENERAL REGULATIONS (Cont'd)2.4 Payment Arrangements and Credit Allowances (Cont'd)2.4.5 Performance Commitment Program

All refunds under the Performance Commitment Program will be provided as a credit adjustment to the customer's bill.

(A) Performance Commitment Program - Provisioning

The Company assures that orders for FIA will be installed and available for customer use no later than the Service Date as referenced in Section 3.2.1, Service Date Intervals. The failure of the Company to meet the service date of an order will result in the refund of all NRCs associated with that order. The Company's liability for failure to meet this commitment is limited to the refund of the NRCs for the order associated with the missed Service Date.

The Performance Commitment Program - Provisioning does not apply:

- (1) when failure to meet the Service Date occurs because of conditions listed in 2.1.3 (G) or due to actions of the customer.
- (2) to Special Construction as provided in Brightspeed Local Operating Companies Tariff F.C.C. No. 5.
- (3) when the Company is not the Access Service Coordination Exchange Carrier (ASC-EC) and the Service Date is not met by the LEC acting as ASC-EC for its portion of the service. See diagram below for indication of when the Company NRC refund will apply:

FACILITIES FOR INTERSTATE ACCESS

2. GENERAL REGULATIONS (Cont'd)

2.4 Payment Arrangements and Credit Allowances (Cont'd)

2.4.5 Performance Commitment Program (Cont'd)

All refunds under the Performance Commitment Program will be provided as a credit adjustment to the customer's bill.

(A) Performance Commitment Program – Provisioning (Cont'd)

The Performance Commitment Program - Provisioning does not apply (Cont'd)

	Brightspeed ASC-EC	Another LEC ASC-EC
Brightspeed Misses Date	Refund applies	Refund applies
Another LEC Misses Date	Refund applies	Refund does not apply

- 4) to Optical Networking Access Services as provided in Section 20.
- 5) to the Expedited Due Date as provided in Section 3.2.2(E).
- 6) to LAN Extension Service as provided in Section 5.6.17.

## FACILITIES FOR INTERSTATE ACCESS

2. GENERAL REGULATIONS (Cont'd)2.5 Connections2.5.1 General

Equipment and systems (i.e., terminal equipment, multiline terminating systems, and communications systems) may be connected with Special Access furnished by the Company where such connection is made in accordance with the provisions specified in the NECA Technical Reference Publication AS No. 1 and in 2.1 preceding.

2.5.2 Standard Access Service Connections

Access services are provided by means of wire, fiber optics, radio or any other suitable technology or a combination thereof. Special Access service connections are made directly or through a Company hub where bridging or multiplexing functions are performed. These connections are analog or digital.

## FACILITIES FOR INTERSTATE ACCESS

2. GENERAL REGULATIONS (Cont'd)2.6 Definitions

Certain terms used herein are defined as follows:

Access Area

The term "Access Area" denotes a specific calling area containing those customers served by one or more Central Offices associated with the various Switched Access provisions offered under this service guide. The size and configuration of the Access Area a customer obtains is dependent upon the Feature Group type and the specific characteristics of the Central Office or Access Tandem office to which the connection is made.

Access Code

The term "Access Code" applies to Switched Access Service. It denotes a uniform seven digit code dialed by an end user to access an Interexchange Carrier's facilities. The Carrier Access Code (CAC) has the form 101XXXX and the Carrier Identification Code (CIC) has the form 950-XXXX.

Access Group

The term "Access Group" denotes a grouping of lines or trunks used to establish a connection between switching systems. Each grouping of lines or trunks is traffic engineered as a unit with each of the individual members of the group having identical characteristics and being interchangeable with any other member of the group.

Access Minutes

The term "Access Minutes" denotes that usage of exchange facilities in interstate or foreign service for the purpose of calculating chargeable usage. On the originating end of an interstate or foreign call, usage is measured from the time the originating End User's call is delivered by the Company to and acknowledged as received by the customer's facilities connected with the originating exchange. On the terminating end of an interstate or foreign call, usage is measured from the time the call is received by the End User in the terminating exchange. Timing of usage at both originating and terminating ends of an interstate or foreign call shall terminate when the calling or called party disconnects, whichever event is recognized first in the originating and terminating end exchanges, as applicable. For the calculation of total minutes, seconds are totaled and converted to minutes before rounding occurs. Remainder seconds greater than 29 are rounded to a minute.



## FACILITIES FOR INTERSTATE ACCESS

2. GENERAL REGULATIONS (Cont'd)2.6 Definitions (Cont'd)Access Service Request

The term "Access Service Request" (ASR) denotes a document (i.e., order) used by the Company to process a customer's request for Access Services as offered throughout this service guide.

Access Tandem

The term "Access Tandem" denotes a telephone company switching system that provides a traffic concentration and distribution function for inter-LATA traffic originating from or terminating at end offices in the access area.

Add/Drop Multiplexing

The term "Add/Drop Multiplexing" denotes a multiplexing function that allows lower level signals to be added or dropped with the remaining traffic continuing through the network.

Agent

The term "Agent" as used in Section 6 of this service guide, is defined as that person or entity that the Company acknowledges as controlling decisions pertaining to Pay telephone Service or, that person or entity duly authorized to act in that capacity by the physical owner of the premises.

Aggregator

The term "Aggregator" denotes any individual, partnership, association, joint-stock company, trust or corporation that, in the ordinary course of its operations, makes telephones available to the public or to transient users of its premises, for interstate telephone calls using a provider of operator services.

Alternate Billing Service

The term "Alternate Billing Service (ABS)" denotes the ability of the end user to bill calls to an account not necessarily associated with the originating line, including calling card, collect and third number billing.

Answer/Disconnect Supervision

The term "Answer/Disconnect Supervision" denotes the transmission of the switch trunk equipment supervisory signal (off-hook or on-hook) to the CDL for terminating calls to the Company end office as an indication that the called party has answered or disconnected.

## FACILITIES FOR INTERSTATE ACCESS

2. GENERAL REGULATIONS (Cont'd)2.6 Definitions (Cont'd)Answer Message

The term "Answer Message" denotes an SS7 message sent in the backward direction to indicate that the call has been answered.

Attempt

The term "Attempt" denotes a call in the originating direction from an end user to the CDL which is completed (answered) or not completed (not answered) and a call in the terminating direction from the CDL to a customer which is completed (Answered) or not completed (not answered).

Attenuation Distortion

The term "Attenuation Distortion" denotes the difference in loss at specified Frequencies relative to the loss at 1004 Hz.

Balance (100-Type) Test Line

The term "Balance (100-Type) Test Line" denotes a standard feature of FGA, FGB, FGC, FGD, 800, 888 Access Service, BSA-A, BSA-B, BSA-C, and BSA-D and refers to the end office termination provided for balance and noise testing. The termination provides off-hook supervision to the calling end, and terminates the line or trunk in a resistive and capacitive arrangement which simulates the characteristic impedance of the end office.

Basic Service Element

The term "Basic Service Element (BSE)" denotes an unbundled service option available only with Basic Serving Arrangements.

Basic Serving Arrangement

The term "Basic Serving Arrangement (BSA)" denotes a category of Switched Access Service differentiated by technical characteristics, e.g., line side versus trunk side connection at the Company's first point of switching.

BHMC

See Busy Hour Minutes of Capacity.

Billed Number Screening

The term "Billed Number Screening (BNS)" denotes the process of utilizing a line information data base to determine billing number acceptance for collect and third number calls and to perform public telephone line number checks to prevent the alternate billing of calls to public coin telephone lines.

## FACILITIES FOR INTERSTATE ACCESS

2. GENERAL REGULATIONS (Cont'd)2.6 Definitions (Cont'd)Bit

The term "Bit" denotes the smallest unit of information in the binary system of notation.

Bridging

The term "Bridging" denotes the connection of one or more circuits in parallel with another circuit without interrupting the continuity of the first circuit.

Bridging Wire Center

The term "Bridging Wire Center" denotes the Company designated wire center in which bridging is accomplished.

Business Data Services

The dedicated point-to-point transmission of data at certain guaranteed speeds and service levels using high-capacity connections.

Business Day

The term "Business Day" denotes the times of day that a company is open for business. Generally, in the business community, these are 8:00 or 9:00 a.m. to 5:00 or 6:00 p.m., respectively, with an hour for lunch, Monday through Friday, resulting in a standard forty (40) hour work week.

Busy Hour Minutes of Capacity

The term "Busy Hour Minutes of Capacity" (BHMC) denotes the trunk group usage load consisting of the average usage load for the busy season.

Busy Season

The term "Busy Season" denotes the four consecutive weeks of the calendar year having the highest daily busiest hour traffic load based on a five day week. Normally the five-day week consists of Monday through Friday. Where weekend traffic is greater than weekday traffic, one or both weekend days may be used as a substitute for a weekday as long as a consistent five-day week is maintained for the four consecutive weeks.

Bit

The term "Bit" denotes a binary digit, the smallest unit of information in the binary system of notation.

## FACILITIES FOR INTERSTATE ACCESS

2. GENERAL REGULATIONS (Cont'd)2.6 Definitions (Cont'd)Byte

The term "Byte" denotes a sequence or group of eight bits that represents one character.

Carrier Identification Code

The term "Carrier Identification Code" (CIC) denotes the uniform access code associated with a specific Interexchange Carrier.

Carrier Identification Parameter

The term "Carrier Identification Parameter" (CIP) denotes a field in the SS7 Initial Address Message (IAM) that identifies and transmits CIC information in a forward direction to an IC customer.

C-Conditioning

The term "C-Conditioning" denotes a Company special treatment of the transmission path in order to control attenuation and envelope delay distortion.

C-Message Noise

The term "C-Message Noise" denotes the frequency weighted average noise within an idle voice circuit. The frequency weighting, called C-message, is used to simulate the frequency characteristic of the 500-type telephone set and the hearing of the average subscriber.

C-Notched Noise

The term "C-Notched Noise" denotes the frequency weighted noise on a voice circuit with a holding tone, which is removed at the measuring end through a notch (very narrow band) filter.

CCS

The term "CCS" denotes a hundred call-seconds which is a standard unit of traffic load that is equal to 100 seconds of usage or capacity of a group of lines or trunks.

Call

The term "Call" denotes a communication including an off-hook signal and routing information initiated at the originating location and completed to a terminating location.

Call Branding

Call Branding is the act of providing customer identification, audibly and distinctly, to the caller at the beginning of a Preferred Directory Assistance call.

## FACILITIES FOR INTERSTATE ACCESS

2. GENERAL REGULATIONS (Cont'd)2.6 Definitions (Cont'd)Cellular Mobile Carrier (CMC)

The term "Cellular Mobile Carrier (CMC)" denotes a Common Carrier authorized by the Federal Communications Commission to provide cellular mobile radio telecommunications services.

Central Office

The term "Central Office" denotes a Company local switching system where Company local service subscriber station loops are terminated for purposes of interconnection to each other and to trunks.

Central Office Loop Around Test Line

The term "Central Office Loop Around Test Line" denotes equipment in the Company's end office which provides a means for making two-way transmission tests for Switched Access services. These transmission tests are normally for the measurement of level and noise tests. This arrangement has two terminations, each reached by means of a separate seven digit number.

Central Office Prefix

The term "Central Office Prefix" denotes the first three digits (NXX) of the telephone number assigned to a telephone company subscriber's local service.

Centralized Automatic Reporting on Trunks (CAROT) Testing

The term "Centralized Automatic Reporting on Trunks (CAROT) Testing" denotes a type of testing which includes the capacity for measuring the 1000 Hz loss, C-message weighted noise, C-notched noise, loss slope, and the provision of a balance termination.

Channelize

The term "Channelize" denotes the process of multiplexing demultiplexing circuits using analog or digital techniques.

Circuit

The term "Circuit" denotes an electrical or photonic, in the case of fiber optic based transmission systems, communications path between two or more points of termination.

Circuit Code

The term "Circuit Code" denotes the service class routing of an SS7 call that indicates the interexchange carrier trunk group to which the traffic will be routed (e.g., 0+, 0-, 500, 900, etc.).

## FACILITIES FOR INTERSTATE ACCESS

2. GENERAL REGULATIONS (Cont'd)2.6 Definitions (Cont'd)Common Channel Signaling System 7 Network (CCS7)

The term "Common Channel Signaling System 7 Network (CCS7)" denotes a dedicated out-of-band signaling network which utilizes Signaling System 7 (SS7) protocol to provide call handling and data base access services.

Common Line

The term "Common Line" denotes a line, trunk, coin line or other facility provided under the Telephone Company General and/or Local Tariffs, terminated on a Central Office switch. A Common Line - Residence is a line or trunk provided under the residence regulations of the Telephone Company General and/or Local Tariffs. A Common Line - Business is a line or trunk provided under the business regulations of the Telephone Company General and/or Local Tariffs. A coin line is a line provided under the public and/or semi-public service regulations of the Telephone Company General and/or Local Tariffs.

Communications System

The term "Communications System" denotes circuits and other facilities which are capable of communications between terminal equipment provided by other than the Company or Company stations.

Competitive Services

All packet-based business data services; circuit-based business data services above the DS3 bandwidth level; transport services which includes interoffice facilities, channel terminations between the serving wire center and point of presence, and all subelements established for the use of these transport facilities; DS1 & DS3 end user channel terminations, and other special access services, in any competitive SWC; DS1 & DS3 end user channel terminations, and other special access services, in a SWC for which the Company was granted pricing flexibility prior to June 2017.

Concatenated

The term "Concatenated" denotes the linking together of various data structures, e.g., two bandwidths joined to form a single bandwidth.

Confirmed ASR

The term "Confirmed ASR" denotes a customer's ASR for a) Switched Access FIA which the Company has processed with the Engineering Department to confirm for the customer and the Company the availability of facilities and/or equipment, and b) Special Access FIA for which the Company confirms to the customer that the established due date can be met. The date the ASR is confirmed, the standard service date interval commences.

## FACILITIES FOR INTERSTATE ACCESS

2. GENERAL REGULATIONS (Cont'd)2.6 Definitions (Cont'd)Confirming Design Layout Report Date

The term "Confirming Design Layout Report (CDLR) Date" identifies the date that the Company is scheduled to receive confirmation that the Design Layout Report provided by the Company for a confirmed ASR is acceptable.

Conventional Signaling

The term "Conventional Signaling" denotes the inter-machine signaling system which has been traditionally used in North America for the purpose of transmitting the called number's address digits from the originating end office to the switching machine which will terminate the call. In this system, all of the dialed digits are received by the originating switching machine, a path is selected, and the sequence of supervisory signals and outpulsed digits is initiated. No overlap outpulsing, ten-digit ANI, ANI information digits, or acknowledgement wink are included in this signaling sequence.

Customer

The term "Customer" denotes any individual, partnership, association, joint-stock company, trust, corporation, or governmental entity or any other entity which subscribes to the services offered under this service guide.

Customer Designated Location

The term "Customer Designated Location" (CDL) denotes a location specified by the customer for the purpose of terminating FIA services. The Company must have access to the location to perform installation, testing, and maintenance functions. The customer may or may not have access to the location. CDLs include locations such as customer premises, end user premises, customer repeater stations, customer microwave towers, a Company's first point of switching, some other point where Company testing can occur, etc. A CDL may be designated by the customer for Switched Access, Special Access, or both in combination. Customer transmission facilities and equipment may be terminated in Company wire centers or access tandems under EIS arrangements, as defined in Section 17. Company Switched and Special Access Services may be interconnected to such customer equipment using Cross Connect arrangements as described in Section 4.5.3 and Section 5.1.1(D), respectively.

D-Conditioning

The term "D-Conditioning" denotes a Company special treatment of the transmission path in order to control C-notched noise and intermodulation distortion.

Daily Busiest Hour

The term "Daily Busiest Hour" denotes the highest usage hour for each day with the reading taken on the clock hour or half hour. The clock hour or half hour selection varies from day to day, depending upon the usage measured. The Daily Busiest Hour is also known as the Bouncing Busy Hour.

## FACILITIES FOR INTERSTATE ACCESS

2. GENERAL REGULATIONS (Cont'd)2.6 Definitions (Cont'd)Data Transmission (107-Type) Test Line

The term "Data Transmission (107-Type) Test Line" denotes an arrangement which provides for the connection to a signal source which provides test signals for one-way testing of data and voice transmission parameters.

Drop Cable

A facility provided by the Company which connects the broadband feeder cable to the premises of the customer's subscribers for the purposes of Video Channel Services.

Dual Tone Multifrequency Address Signaling

The term "Dual Tone Multifrequency (DTMF) Address Signaling" denotes a type of signaling that is an optional feature of FGA and BSA-A. It may be utilized when FGA or BSA-A is being used in the terminating direction. An office arranged for signaling would expect to receive address signals from the IC in the form of DTMF format.

Echo Path Loss

The term "Echo Path Loss" denotes the measure of reflected signal at a four-wire interface without regard to the send and receive Transmission Level Point (TLP).

Echo Return Loss

The term "Echo Return Loss" denotes a frequency weighted measure of return loss over the middle of the voiceband (approximately 500 to 2500 Hz) where talker echo is most annoying.



## FACILITIES FOR INTERSTATE ACCESS

2. GENERAL REGULATIONS (Cont'd)2.6 Definitions (Cont'd)End Office Switch

The term "End Office Switch" denotes a Company local switching system located in a wire center where Company local service subscriber station loops are terminated for purposes of originating and terminating traffic to or from a customer.

End User

The term "End User" means any customer of an interstate or foreign telecommunications service that is not a carrier, except that a carrier, other than the Company, shall be deemed to be an "end user" to the extent that such carrier uses a telecommunications service for administrative purposes, and a person or entity that offers telecommunications services exclusively as a reseller shall be deemed to be an "end user" if all resale transmissions offered by such reseller originate on the premises of such reseller (e.g., hotels, motels and shared tenant services).

Engineering Review

The term "Engineering Review" denotes the examination of an ASR with a customer requested change to determine if a design change is required. It includes, but is not limited to, the review for possible change requirements in equipment, interfaces, circuit configurations, engineering records, and billing.

Entry Switch

See First Point of Switching.

Excess Capacity

The term "Excess Capacity" denotes a quantity of FIA requested by the customer which is greater than that which the Company would construct to fulfill the customer's ASR.

Exchange

The term "Exchange" denotes a unit generally smaller than a Local Access and Transport Area (LATA), established by the Company for the administration of communications service in a specified area which usually embraces a city, town or village and its environs. It consists of one or more central offices together with the associated facilities used in furnishing communications service within that area. One or more designated exchanges comprise a given LATA.

Exchange Access Signaling

The term "Exchange Access Signaling" denotes the signaling system used by equal access end offices to transmit originating information and address digits to the customer's premises and includes the means of verifying the receipt of these address digits. Features of this system include overlap outputting (in suitably equipped end offices), identification of the type of call, identification of the ten-digit telephone number of the calling party, and acknowledgement wink supervisory signals.

## FACILITIES FOR INTERSTATE ACCESS

2. GENERAL REGULATIONS (Cont'd)2.6 Definitions (Cont'd)Existing Suitable Space

The term "Existing Suitable Space" denotes a space in which ac/dc power, heat and air conditioning, battery and generator back-up power, and other requirements necessary for provision of wire center or access tandem equipment currently exists.

Exit Message

The term "Exit Message" denotes an SS7 message sent to an end office by the Company tandem switch to mark the connect time when the Company's tandem switch sends an Initial Address Message to a customer.

Extended Area Service

The term "Extended Area Service" (EAS) denotes an arrangement whereby a customer in one exchange can call a local number in another exchange that is part of the extended area without paying a toll charge.

Facility

The term facility denotes generically the various transmission media used for the transmission of telecommunication services. This includes, but is not limited to, cable (copper pair, coaxial, and fiber optic) and microwave radio equipment.

Firm Order Confirmation Date

The term "Firm Order Confirmation (FOC) Date" denotes the date that the Company will provide the schedule of dates for the provisioning activities associated with the customer's request for service.

First Point of Switching

The term "First Point of Switching" denotes either the first Company location at which switching occurs on the terminating path of a call proceeding from the CDL to the terminating end office or the last Company location at which switching occurs on the originating path of a call proceeding from the originating end office to the CDL.

Flexible Automatic Number Identification (FLEX ANI)

The term "Flexible Automatic Number Identification" denotes an optional feature or Basic Service Element that provides additional values for the information indicator digits available with the ANI feature on originating calls. These additional digits identify the type of line that is originating the call for billing, screening and routing purposes.

## FACILITIES FOR INTERSTATE ACCESS

2. GENERAL REGULATIONS (Cont'd)2.6 Definitions (Cont'd)Four-Wire to Two-Wire Conversion

The term "Four-Wire to Two-Wire Conversion" denotes an arrangement which converts a four-wire transmission path to a two-wire transmission path to allow a four-wire facility to terminate in a two-wire entity such as a central office switch trunk circuit or switching system.

Frame

The term "Frame" denotes a group of data bits, in a specific format, with a flag at either end to indicate the beginning and end of the frame. The defined format enables network equipment to recognize the meaning and purpose of specific bits.

Gateway Switch

The switch through which communication passes between public packet switched networks.

Geographically Aggregated Rate (GAR)

The term "Geographically Aggregated Rate" denotes a situation in which the rates and charges for a service offering, for which there is currently no demand, are developed based upon the aggregated revenue requirement and demand for more than one study area. Upon receipt of a request for service, the current geographically averaged rates will be redeveloped to include the new study area.

Example: Study areas A, B and C have been geographically aggregated. Geographically averaged rates for A and B were developed based upon their aggregated revenue requirement and demand, while Area C, marked "GAR", has no current demand. Should C receive a request for service, the current geographically averaged rates will be redeveloped to include C's revenue and demand. The redeveloped rates and charges will now be applicable to customers on A, B and C.

Ground Start Supervisory Signaling

The term "Ground Start Supervisory Signaling" denotes a type of signaling which provides for the application of ground on the tip side at the point of termination (assuming no signaling conversion has been provided by the Company) as an initial seizure signal before the application of ringing in the originating direction (towards the customer from the end office).

## FACILITIES FOR INTERSTATE ACCESS

2. GENERAL REGULATIONS (Cont'd)2.6 Definitions (Cont'd)Head-End

The Company location where analog video and audio signals are received from the customer for transmission over the broadband distribution facilities to subscribers for the purposes of providing Video Channel Services.

Immediately Available Funds

The term "Immediately Available Funds" denotes a corporate or personal check drawn on a bank account and funds which are available for use by the receiving party on the same day on which they are received and includes U.S. Federal Reserve bank wire transfers, U.S. Federal Reserve notes (paper cash), U.S. coins, U.S. Postal Money Orders, and New York Certificates of Deposit.

Individual Case Basis

The term "Individual Case Basis" (ICB) denotes a condition where the regulations, if applicable, rates and charges for an offering under the provisions of this service guide are developed based on the circumstances in each case.

Information Service Provider

The term "Information Service Provider" denotes one who offers a capability for generating, acquiring, storing, transforming, processing, retrieving, utilizing, or making available information which may be conveyed via telecommunications, except that such service does not include (1) any use of any such capability for the management, control, or operation of a telecommunications system or the management of a telecommunications service, or (2) the provision of time, weather, and such other similar audio services that are offered by any Brightspeed Local Operating Company.

Initial Address Message (IAM)

The term "Initial Address Message (IAM)" denotes an SS7 message sent in the forward direction to initiate trunk set up with the busying of an outgoing trunk which carries the information about that trunk along with other information relating to the routing and handling of the call to the next switch.

Installed Cost

The term "Installed Cost" denotes the total cost (estimated or actual) by the Company to provide facilities for the offered services.

## FACILITIES FOR INTERSTATE ACCESS

2. GENERAL REGULATIONS (Cont'd)2.6 Definitions (Cont'd)Interconnection

The term "Interconnection" denotes the termination of a customer's basic transmission facilities, including optical terminating equipment and multiplexers at or near Company wire center or access tandem. Interconnection is provided as physical or virtual.

Interconnection Point

The term "Interconnection Point" denotes physical EIS arrangements as the point where the customer-owned cable facilities connect to the Company termination equipment. The interconnection point for virtual EIS arrangements is the demarcation between ownership of the cable facilities.

Interexchange Carrier (IC) or Interexchange Common Carrier

The terms "Interexchange Carrier" (IC) or "Interexchange Common Carrier" denote any individual, partnership, association, joint stock company, trust, governmental entity or corporation engaged for hire in interstate or foreign communication by wire or radio, between two or more LATAs.

Intermodulation Distortion

The term "Intermodulation Distortion" denotes a measure of the nonlinearity of a circuit. It is measured using four tones, and evaluating the ratios (in dBs) of the transmitted composite four-tone signal power to the second-order products of the tones (R2), and the third-order products of the tones (R3).

Interstate Communications

The term "Interstate Communications" denotes both interstate and foreign communications.

Intrastate Communications

The term "Intrastate Communications" denotes any communications within a state subject to oversight by a state regulatory commission as provided by the laws of the state involved.

Kilosegment

The term "Kilosegment" denotes a unit of packet transmission defined as 64,000 bytes of data; one thousand segments.

## FACILITIES FOR INTERSTATE ACCESS

2. GENERAL REGULATIONS (Cont'd)2.6 Definitions (Cont'd)Local Area Network (LAN)

A network permitting the interconnection and intercommunication of a group of computers, primarily for the sharing of resources such as data storage devices and printers.

Line

The term "Line" denotes a communications path connecting an end office switch with an end user's premises or a CDL for the provision for FGA or BSA-A.

Line Group

The term "Line Group" denotes a grouping of lines which are traffic engineered as a unit for the establishment of connections between end office switches and customers in which all of the communications paths are interchangeable.

Line Information Data Base

The term "Line Information Data Base (LIDB)" denotes a data base containing billing validation data providing the ability to screen billed numbers to support Alternate Billing services.

Line Side Connection

The term "Line Side Connection" denotes a connection of a transmission path to the line side of an end office system.

Local Access and Transport Area

The term "Local Access and Transport Area" (LATA) denotes a geographic area for the provision and administration of communications service. It encompasses designated Access Areas which are grouped to serve common social, economic, and other purposes.

Logical Channel

The term "Logical Channel" denotes a communication channel which allows two-way simultaneous transmission of data packets through the network. No circuit capability is pre-assigned to a logical channel. Capacity is made available as the data is transmitted. Each virtual connection utilizes one logical channel.

## FACILITIES FOR INTERSTATE ACCESS

2. GENERAL REGULATIONS (Cont'd)2.6 Definitions (Cont'd)Maximum Termination Liability

The term "Maximum Termination Liability" (MTL) denotes the maximum amount of money for which the customer is liable in the event all FIA ordered in a Special Construction case are discontinued before a specified period of time.

Maximum Termination Liability Period

The term "Maximum Termination Liability Period" denotes the length of time the customer is liable for a termination charge in the event specially constructed FIA are terminated. The MTL period is equal to the average account life of the FIA provided.

Metropolitan Statistical Area (MSA)

The term "Metropolitan Statistical Area (MSA)" denotes a prescribed geographic area comprised of Company Wire Centers which has been grouped together.

Mid Link

The term "Mid Link" denotes the Special Transport facilities between Hub Wire Centers where the circuit is bridged and/or where switching devices such as a loop transfer arrangement are located.

Milliwatt (102 Type) Test Line

The term "Milliwatt (102-Type) Test Line" denotes an arrangement in an end office which provides a 1004 Hz tone at 0 dBm0 for one-way transmission measurements towards the CDL from the Company end office.

Mobile Telephone Switching Office (MTSO)

The term "Mobile Telephone Switching Office (MTSO)" denotes a Cellular Mobile Carrier (CMC) switching facility that is used to originate or terminate calls on the CMC network, or originate or terminate calls between the CMC and the public switched telephone network.

Multicarrier Access Area

The term "Multicarrier Access Area" denotes an EAS for FGA and BSA-A or an area for FGB and BSA-B where FIA Services are provided by more than one telephone company in which a customer obtains access to an entire EAS or FGB or BSA-B area by obtaining a FGA or BSA-A, or FGB or BSA-B access tandem arrangement that connects its switch with the First Point of Switching of the Primary Exchange Carrier.

## FACILITIES FOR INTERSTATE ACCESS

2. GENERAL REGULATIONS (Cont'd)2.6 Definitions (Cont'd)National Security Emergency Preparedness (NSEP) Services

The term "National Security Emergency Preparedness (NSEP) Services" denotes telecommunications services which are used to maintain a state of readiness or to respond to and manage any event or crisis (local, national or international), which causes or could cause injury or harm to the population, damage to or loss of property, or degrades or threatens the NSEP posture of the United States.

Net Salvage

The term "Net Salvage" denotes the estimated scrap, sale, or trade-in value, less the estimated cost of removal. Cost of removal includes the costs of demolishing, tearing down, removing, or otherwise disposing of the material and any other applicable costs. Because the cost of removal may exceed salvage, facilities may have negative net salvage.

Network Address

The term "Network Address" denotes the alphanumeric character string used to specify the destination of each switched connection made within the network.

Network Channel Interface Code

The "Network Channel Interface" code (NCI) is an ordering code that provides an indication of the generic channel type. The NCI code provides the technical characteristics of the interface and describes the physical and electrical characteristics of the special access interface to the customer designated locations. A complete description and listing of these interface codes is specified in Section 6'103 of the GTE Technical Interface Reference Manual.

Node

The term "Node" denotes a SONET ring service element that designates either a customer designated location or a Company wire center location on the SONET ring. It also denotes the location/address of where a channelized service originates or terminates on a ring.

Non-Competitive Serving Wire Center

A Company Serving Wire Center that has not met the Competitive Market Test as established by the FCC's BDS Order (17-43) on April 28, 2017 at §69.803.

Non-Overlap Outpulsing

The term "Non-Overlap Outpulsing" is the feature of the exchange access signaling system which provides initiation of pulsing to the customer's premises after the calling subscriber has completed dialing an originating call.



## FACILITIES FOR INTERSTATE ACCESS

2. GENERAL REGULATIONS (Cont'd)2.6 Definitions (Cont'd)Nonrecoverable Cost

The term "Nonrecoverable Cost" denotes the cost of specially constructed facilities for which the Company has no foreseeable use should the customer terminate service.

Nonsynchronous Test Line

The term "Nonsynchronous Test Line" denotes an arrangement in step-by-step end offices which provides operational tests which are not as complete as those provided by the synchronous test lines, but which can be made more rapidly.

North American Numbering Plan

The term "North American Numbering Plan" denotes a three-digit area or Numbering Plan Area (NPA) code and a seven-digit telephone number made up of a three-digit Central Office code (NXX) plus a four-digit station number (XXXX).

NSEP Treatment

The term "NSEP Treatment" denotes the provisioning of a telecommunications service before others based on the provisioning priority level assigned by the Executive Office of the President.

Octet

The term "Octet" denotes a group of eight binary digits operated upon as an entity.

Off-Hook

The term "Off-Hook" denotes the active condition of Switched Access or a Company local service line.

On-Hook

The term "On-Hook" denotes the idle condition of Switched Access or a Company local service line.

Open Circuit Test Line

The term "Open Circuit Test Line" denotes an arrangement in an end office which provides an ac open circuit termination of the trunk or line by means of an inductor of several Henries.

Optical Carrier Rate (OC-N)

The term "OC-N" denotes an Optical Networking transmission signal, speed, line rate, or service and may be commonly referred to as follows:

<u>OC-N Rate</u>	<u>Bandwidth Capacity</u>
OC-1	51.84 Mbps
OC-3	155.52 Mbps
OC-12	622.08 Mbps
OC-24	1.25 Gbps
OC-48	2.488 Gbps

## FACILITIES FOR INTERSTATE ACCESS

2. GENERAL REGULATIONS (Cont'd)2.6 Definitions (Cont'd)Order Interval

The term "Order Interval" denotes the interval between the Scheduled Issue Date and the Service Date.

Originating Direction

The term "Originating Direction" denotes the use of Switched Access for the origination of calls from an end user to a CDL.

Originating Point Code

The term "Originating Point Code (OPC)" denotes the identity assigned to each Operator Service System (OSS) location.

Overlap Outpulsing

The term "Overlap Outpulsing" is the feature of the exchange access signaling system which permits initiation of pulsing to the customer's premises before the calling subscriber has completed dialing an originating call.

OZZ Code

The term "OZZ Code" denotes the service class routing code of a multifrequency (MF) call that indicates the interexchange carrier trunk group to which the traffic will be routed (e.g., 0+, 0-, 500, 900, etc.).

Packet

The term "Packet" denotes a continuous sequence of binary digits of information which is switched through the network as an integral unit. The user data is divided into segments for billing purposes. The number of segments contained in a packet is dependent upon the packet size.

Packet Switch

The term "Packet Switch" denotes a central office based switch that establishes a virtual connection between two data network addresses for the transmission of discrete amounts of information.

Packet Switching Office

The term "Packet Switching Office" denotes the central office where the packet switching functions are performed and access to the packet network is accomplished.

## FACILITIES FOR INTERSTATE ACCESS

2. GENERAL REGULATIONS (Cont'd)2.6 Definitions (Cont'd)Payload

The term "Payload" denotes the portion of the SONET signal available to carry service signals such as DS0, DS1, and DS3.

Physical EIS

The term "Physical EIS" denotes an offering that enables customers to place equipment needed to terminate basic transmission facilities, including optical terminating equipment and multiplexers, within or upon the Company's wire center or Company access tandem buildings, use such equipment to connect customer's fiber optic systems or microwave radio transmission facilities (where reasonably feasible) with the local exchange carrier's equipment and facilities used to provide interstate switched and special access services.

Plant Test Date

The term "Plant Test Date" denotes the date on which installation is completed and the Company to customer testing can begin.

Point of Termination

The term "Point of Termination" denotes the point of demarcation at a CDL or end user premises at which the Company's responsibility for the provision of FIA Service ends.

Premises

The term "Premises" denotes a building or buildings on continuous property (except Railroad Right-of-Way, etc.) not separated by a public highway.

Pre-service Testing

The term "Pre-service Testing" denotes tests performed on a FIA to assure standard transmission performance/parameters meet specifications prior to acceptance testing.

Primary Exchange Carrier

The term "Primary Exchange Carrier" (PEC) denotes the telephone company in whose exchange a customer's first point of switching (i.e., dial tone for FGA or BSA-A, an access tandem for FGB or BSA-B) is located.

Protocol

The term "Protocol" denotes a set of rules governing the format to be followed when transmitting information between communicating devices.

## FACILITIES FOR INTERSTATE ACCESS

2. GENERAL REGULATIONS (Cont'd)2.6 Definitions (Cont'd)Public Pay Telephone

The term "Public Pay Telephone" denotes a switched coin line provided under the Public Telephone Service regulations of the Company's General Exchange and/or Local Exchange Tariffs.

Query

The term "Query" denotes a Signaling System 7 (SS7) message requesting specific information from a data base.

Recoverable Cost

The term "Recoverable Cost" denotes the cost of specially constructed facilities for which the Company has a foreseeable reuse, either in place or elsewhere should the customer terminate service.

Registered Equipment

The term "Registered Equipment" denotes the customer's terminal equipment which complies with or has been approved within the Registration Provisions of Part 68 of the FCC Rules and Regulations.

Release Message

The term "Release Message" denotes an SS7 Message sent in either direction to indicate that a specific circuit is being released.

Response

The term "Response" denotes an SS7 message representing a reply to a request for information contained in a query.

Route Mileage

The term "Route Mileage" denotes the actual Company provided facility mileage of a transmission circuit.

Scheduled Issue Date

The term "Scheduled Issue Date" denotes the date the Company is scheduled to issue the confirmed ASR to all associated work groups.

## FACILITIES FOR INTERSTATE ACCESS

2. GENERAL REGULATIONS (Cont'd)2.6 Definitions (Cont'd)Secondary Exchange Carrier

The term "Secondary Exchange Carrier" (SEC) denotes the telephone company in whose exchange a customer does not subscribe to FGA or BSA-A, or FGB or BSA-B service, but from whose exchange the customer's end users can call the interexchange switch or CDL of an IC in the primary exchange of another telephone company on a toll-free basis.

Segment

The term "Segment" denotes a unit of user information consisting of 64 octets or less. Billing for Packet Switching Network Service is based on the number of segments transmitted within the user data field of a packet. The number of segments transmitted within a packet is limited only by the subscribed or negotiated maximum size of the user data field for the customer interface.

Semi-Public Pay Telephone

The term "Semi-Public Pay Telephone" denotes a switched coin line provided under the Semi-Public Telephone Service regulations of the Company's General and/or Local Tariffs.

Service Control Point

The term "Service Control Point (SCP)" denotes an SS7 network control interface element between the Company's SS7 network and one or more data bases.

Service Date

The term "Service Date" denotes the date that the FIA is to be placed in service. A confirmed ASR is required to establish a service date.

Service Switching Point (SSP)

The term "Service Switching Point" (SSP) denotes a signal point equipped with the ability to halt call process, formulate and send a SS7 query to a remote location and route the call based on information contained in the response.

Serving Wire Center

The term "Serving Wire Center" denotes the wire center from which the customer designated location would normally obtain dial tone from the Company. The "Serving Wire Center" is designated by the Company based upon the location being served.

## FACILITIES FOR INTERSTATE ACCESS

2. GENERAL REGULATIONS (Cont'd)2.6 Definitions (Cont'd)Seven-Digit Manual Test Line

The term "Seven-Digit Manual Test Line" denotes a set of optional features for all Switched Access which allow the IC to select balance, milliwatt, and synchronous test lines of FGA and BSA-A, by manually dialing a seven-digit number over the associated Switched Access.

Short Circuit Test Line

The term "Short Circuit Test Line" denotes the end office circuit which provides an ac short circuit termination of the trunk or line by means of a capacitor of at least 4 microfarads.

Signaling Point

The term "Signaling Point (SP)" denotes an SS7 network interface element capable of originating and/or terminating SS7 messages.

Signaling System 7 (SS7)

The term "Signaling System 7 (SS7)" denotes the layered protocol used for standardized common channel signaling in the United States.

Signal Transfer Point (STP)

The term "Signal Transfer Point (STP)" denotes a packet switch which provides access to the Company's SS7 network and performs SS7 message signal routing and screening. The technical interface specifications, transmission specifications, and diversity requirements for interconnecting to the Company's SS7 network at the STP are as described in Bellcore Technical Reference Publication TR-TSV-000905.

Signal Transfer Point (STP) Port

The term "Signal Transfer Point (STP) Port" denotes the physical point of termination and interconnection to the STP.

Statistical Multiplexing

A multiplexing technique in which timeslots are dynamically allocated on the basis of need rather than being predetermined; the data is typically transmitted on a first served basis.

SONET

The term "SONET" (Synchronous Optical Network) denotes a family of fiber optic transmission bit rates starting at 51.84 Mbps, designed to provide the flexibility needed to transport many digital signals with different capacities.

## FACILITIES FOR INTERSTATE ACCESS

2. GENERAL REGULATIONS (Cont'd)2.6 Definitions (Cont'd)Synchronous Test Line

The term "Synchronous Test Line" denotes an arrangement of an end office which performs marginal operational tests of supervisory and ring-trip functions.

Synchronous Transfer Module (STM)

STM-1 is the international equivalent SONET's OC3 transmission rate.

Telecommunications Service Priority (TSP) System

The term "Telecommunications Service Priority (TSP) System" or "TSP System" refers to the regulatory, administrative and operational system authorizing and providing for priority treatment (i.e., the provisioning and restoration) of NSEP Services.

Temporary Facilities

The term "Temporary Facilities" denotes facilities used to provide FIA to a customer for less than the minimum service period or less than one month, whichever is longer, or to provide FIA while permanent facilities are being constructed.

Terminating Direction

The term "Terminating Direction" denotes the use of Switched Access for the completion of calls from a CDL to an end user.

Toll VoIP-PSTN Traffic

The term "Toll VoIP-PSTN Traffic" denotes a customer's interexchange voice traffic exchanged with the Company in Time Division Multiplexing format over PSTN facilities, which originates and/or terminates in Internet Protocol (IP) format. "Toll VoIP-PSTN Traffic" originates and/or terminates in IP format when it originates from and/or terminates to an end user customer of a service that requires IP-compatible customer premises equipment.

Trunk

The term "Trunk" denotes a communications path connecting two switching systems in a network, used in an end-to-end connection.

Trunk Group

The term "Trunk Group" denotes a grouping of trunks which are traffic engineered as a unit for the establishment of connections between switching systems in which all of the communications paths are interchangeable.

Trunk Side Connection

The term "Trunk Side Connection" denotes the connection of a transmission path to the trunk side of an end office switch.

## FACILITIES FOR INTERSTATE ACCESS

2. GENERAL REGULATIONS (Cont'd)2.6 Definitions (Cont'd)U.S. Domestic Offshore Points

The term "U.S. Domestic Offshore Points" denotes any U.S. location that is not part of the conterminous United States.

V&H Coordinates Method

The term "V&H Coordinates Method" denotes a method of computing airline miles between two points by utilizing an established formula which is based on the Vertical (V) and Horizontal (H) coordinates of the two points.

Virtual EIS

The term "Virtual EIS" denotes an offering that enables customers to designate or specify equipment needed to terminate basic transmission facilities, including optical terminating equipment and multiplexers, to be located within or upon Company's wire center or access tandem buildings, and dedicated to such customers use.

Virtual Connection

The term "Virtual Connection" denotes a logical channel resulting from call establishment to a network address that exists until the call is terminated by either party.



## FACILITIES FOR INTERSTATE ACCESS

2. GENERAL REGULATIONS (Cont'd)2.6 Definitions (Cont'd)WATS Serving Office

The term "WATS Serving Office" denotes a Company designated serving wire center where switching, screening and/or recording functions are performed in connection with a Special Access Line used with a Switching Interface as in 4.2.5(V) #.

Wire Center

The term "Wire Center" denotes a location in which one or more central office switches, and cross connection equipment used for the provision of Company telecommunications services, are located.

Wire Center Area

The term "Wire Center Area" denotes the geographic area served by a Wire Center through the use of central office switching equipment, cross connection equipment, and subscriber loops.

X.25 Protocol

The term "X.25 Protocol" denotes an interface between Data Terminal Equipment and Data Circuit Terminating Equipment for terminals operating in the packet mode on public data networks.

X.75 Protocol

The term "X.75 Protocol" denotes terminal and transit call control procedures and data transfer system on circuits between packet switched data networks.

- # The use of the terms WATS or WATS-type throughout this service guide is primarily for ordering purposes and is not intended to restrict the use of the customer services when ordering Special Access and Switched Access in combination.

## FACILITIES FOR INTERSTATE ACCESS

2. GENERAL REGULATIONS (Cont'd)2.7 FIA Services Provided By More Than One Telephone Company2.7.1 General

When Switched Transport or Special Transport service is provided by more than one telephone company, the telephone companies involved will mutually agree upon one of the billing methods based upon the type of access service and the interconnection arrangements between the telephone companies.

The telephone company will notify the customer which billing method will be used. The telephone company receiving the ASR from the customer will arrange to provide the service and bill the customer as in 2.7.2.

2.7.2 Single Company Billing

The telephone company receiving the ASR from the customer, as specified in 2.7.1, will arrange to provide the service, determine the applicable charges and bill the customer for the entire service in accordance with its Access tariff. The airline mileage is determined using the V&H method in the Exchange Carrier Association (ECA) Tariff FCC No. 4.

2.7.3 Meet Point Billing

Meet Point Billing is required when an access service is provided by multiple Telephone Companies\* for Special Access.

There are two Meet Point Billing Options -- Single Bill and Multiple Bill. The Telephone Company must notify the customer of:

- the Meet Point Billing Option that will be used,
- the Telephone Company(s) that will render the bill(s),
- the Telephone Company(s) to whom payment(s) should be remitted, and
- the Telephone Company(s) that will provide the bill inquiry function.

The Telephone Company shall provide such notification at the time that an ASR is placed requesting access service. Additionally, the Telephone Company shall provide this notice in writing 30 days in advance of any change.

(A) Single Bill Option

The Single Bill Option allows the customer to receive one bill from one telephone company or its billing agent for access services.

The Telephone Company(s) that renders the bill to the customer may provide to the customer, cross references to the other Telephone Company(s) service and/or the common circuit identifiers based upon industry standards as contained in the MECAB document. Should a billing dispute arise, the terms and conditions of the Billing Company(s) will apply.

\* Meet Point Billing option guidelines, as contained in the MECAB document, may also be applied to FIA services provided by one exchange carrier in two or more states within a single LATA.

## FACILITIES FOR INTERSTATE ACCESS

2. GENERAL REGULATIONS (Cont'd)2.7 FIA Services Provided By More Than One Telephone Company (Cont'd)2.7.3 Meet Point Billing (Cont'd)(A) Single Bill Option (Cont'd)

The Single Bill option provides three billing alternatives, Single Bill/Single Tariff, Single Bill/Pass-Through Billing and Single Bill/Multiple Tariff which are described following:

## (1) Single Bill/Single Tariff

Each telephone company will provide its portion of the Special Transport service within its operating territory to the meet point with the other telephone company(s). The BP will be determined by the telephone companies involved in providing the FIA service and listed in the ECA Tariff FCC No. 4.

For all Special Access Services the order will be placed with the telephone company as specified in the Ordering and Billing Forum's Multiple Exchange Carrier Ordering and Design (MECOD) guidelines.

Each Telephone Company will receive an ASR or a copy of the ASR from the customer and arrange to provide the service. The Initial Billing Company will:

- determine the applicable charges and bill in accordance with its tariff;
- include all recurring and nonrecurring rates and charges of its tariff; and
- forward the bill to the customer.

The customer will remit the payment to the Initial Billing Company.

## (2) Single Bill/Pass-Through Billing

Each Telephone Company will receive an ASR or a copy of the ASR from the customer as specified (1) and arrange to provide the service.

Each Telephone Company will:

- determine its portion of Special Transport as in 2.7.3(C);
- determine the applicable charges and bill in accordance with its tariff;
- include all recurring and nonrecurring rates and charges of its tariff; and
- forward the bill to the Initial Billing Company for meet point billed access services.

## FACILITIES FOR INTERSTATE ACCESS

2. GENERAL REGULATIONS (Cont'd)2.7 FIA Services Provided By More Than One Telephone Company (Cont'd)2.7.3 Meet Point Billing (Cont'd)(A) Single Bill Option (Cont'd)

## (2) Single Bill/Pass-Through Billing (Cont'd)

The Initial Billing Company will:

- apply usage data, when needed, to the bill and calculate the charges;
- identify each involved Telephone Company's charges separately on the bill;
- combine all the bills of the involved Telephone Companies of a meet point billed access service into one access bill;
- forward the bill to the customer; and
- advise the customer how to remit the payment, either directly to each Telephone Company involved in the provision of this meet point billed service; or, as a single payment made to the Initial Billing Company. If payments are to be sent directly to the Initial Billing Company, the Subsequent Billing Company(s) will provide the customer with written authorization for the payment arrangement.

## (3) Single Bill/Multiple Tariff

Each Telephone Company will receive an ASR or a copy of the ASR from the customer as specified in (1) and arrange to provide the service. The Initial Billing Company will:

- determine each Telephone Company's portion of special transport as set forth in 2.7.3(C);
- determine the applicable charges and bill in accordance with each Telephone Company's tariff;
- include all recurring and nonrecurring charges for each involved Telephone Company;
- identify each involved Telephone Company's charges separately on the bill;
- forward the bill to the customer; and
- advise the customer how to remit the payment, either directly to each Telephone Company involved in the provision of this meet point billed service; or, as a single payment made to the Initial Billing Company. If payments are to be sent directly to the Initial Billing Company, the Subsequent Billing Company(s) will provide the customer with written authorization for the payment arrangement.

## FACILITIES FOR INTERSTATE ACCESS

2. GENERAL REGULATIONS (Cont'd)2.7 FIA Services Provided By More Than One Telephone Company (Cont'd)2.7.3 Meet Point Billing (Cont'd)(B) Multiple Bill Option

The Multiple Bill option allows all Telephone Companies providing service to bill the customer for their portion of a jointly provided access service. Each Telephone Company will:

- determine its portion of the Special Transport as set forth in 2.7.3(C);
- determine the applicable charges and bill in accordance with its tariff;
- include all recurring and nonrecurring rates and charges of its tariff; and
- forward the bill to the customer.

The customer will remit the payments directly to each Telephone Company.

(C) Meet Point Billing Mileage Calculation

Each Telephone Company's portion of the Special Transport mileage will be determined as follows:

- (1) For Special Access Services determine the appropriate Special Transport total miles by computing the number of miles between the serving wire centers involved using the V&H method as set forth in the NECA Tariff FCC No. 4. Where the calculated miles include a fraction, the value is rounded up to the next full mile.
  - (2) Determine the billing percentage (BP), as set forth in the NECA Tariff FCC No. 4. This represents the portion of the Service provided by each telephone company.
  - (3) For Special Access, multiply the number of airline miles as in (1), times the BP for each telephone company as in (2), times the Special Transport rate elements.
- (D) All other appropriate recurring and nonrecurring charges in each telephone company's Access tariff are applicable.

2.7.4 Reserved for Future Use

## FACILITIES FOR INTERSTATE ACCESS

3. ORDERING OPTIONS FOR FIA3.1 General

This section sets forth the regulations and order related charges for FIA Orders to provide the customer with FIA. These charges are in addition to other applicable charges in other sections of this service guide.

3.1.1 Ordering Conditions

- (A) A customer may order any amount of FIA (Special) of the same interface type, same BSA or same Special Access between the same locations for installation on the same date on a single FIA ASR. A customer may order the shared use of Switched Access and Special Access over the same high capacity facility however, separate FIA ASRs are required. The methodology for shared use is set forth in 5.6.7.
- ASRs for SAC Access Service must specify the number of trunks required or Busy Hour Minutes of Capacity (BHMC).
- (B) The customer shall supply all details necessary to complete an order. The details may include the following: requested service date, customer name, customer designated location, end office, Interface Arrangement, type of Special Access, Supplemental Features, End Office Services and Signaling Interface, and originating and terminating capacity required. The customer may also be required to provide end user name and location, end user contact person, and end user premises access information to complete an order for Special Access.

When a customer orders mixed interstate and intrastate Switched Access, the customer is required to provide an estimate of the percent of traffic, as described in Brightspeed Local Operating Companies Tariff F.C.C. No. 2, Section 4.3.3, which will be interstate. If the customer fails to provide this estimate, the order will not be processed until such time as the customer provides this estimate.

When a customer orders mixed-use special access service, the customer must indicate the jurisdiction based on the criteria in Section 5.1.6.

For Packet Switching Network Service, the packet carrier must provide a Percent of Interstate Usage (PIU) in the Main Remarks section of the ASR when service is initially ordered. This PIU will be used as the basis for prorating the packet usage charges to the interstate and intrastate jurisdictions. The packet switching carrier may submit an updated PIU report in writing at any time following one full month's billing. The updated report will become effective on the first day of the next monthly billing period which begins at least 15 business days after the date the revised report is received by the Telephone Company.

## FACILITIES FOR INTERSTATE ACCESS

3. ORDERING OPTIONS FOR FIA (Cont'd)3.1 General (Cont'd)3.1.2 Provision of Other Services

- (A) At the option of a customer, Additional Labor, Telecommunications Service Priority (TSP), Testing and Special Routing services may be ordered with an ASR at the same time the ASR is accepted by the Company. Such requests will be considered to be supplemental to the ASR. The rates and charges for these services as set forth in other sections of this service guide will apply in addition to the ordering charges set forth in this section and the rates and charges for the Special Access with which they are associated.
- (B) The items listed in (A) preceding may subsequently be added to the ASR at any time, up to and including the service date established by the ASR. When ordered subsequently, charges for ASR modifications as set forth in 3.2.2 will apply.

3.1.3 Special Construction

The regulations, rates and charges for Special Construction are in Brightspeed Local Operating Companies Tariff F.C.C. No. 5 in addition to the regulations, rates and charges specified in this section.

3.1.4 Reserved For Future Use3.1.5 Reserved For Future Use3.2 Access Service Request

An ASR is used by the Company to receive orders for the following types of FIA requested by the customer:

- Special Access as in Section 5,
- Other Services as in other sections of the service guide.

3.2.1 Service Date Intervals

The time required to provision service is known as the service date interval. Such intervals will be established in accordance with published service date interval guidelines which are available to customers upon request. The service date interval guidelines will apply to ASRs and will specify the quantities of FIA that can be provided on the same service date. The customer may request a service date other than that established pursuant to the service date interval guidelines, and the Company, where possible, will establish the service date in accordance with such request, subject, however, to other applicable provisions of this service guide.

## FACILITIES FOR INTERSTATE ACCESS

3. ORDERING OPTIONS FOR FIA (Cont'd)3.2 Access Service Request (Cont'd)3.2.2 ASR Modifications

The customer may request a modification of its ASR prior to the service date. The Company will make every effort to accommodate a requested modification when it is able to do so with the normal work force assigned to complete such an ASR within normal business hours. If the modification cannot be made with the normal work force during normal business hours, the Company will notify the customer. If the customer still desires the ASR modification, the Company will schedule a new service date. All charges for ASR modifications will apply on a per occurrence basis. Where a new ASR may be required the appropriate charges in other sections of this service guide will be applicable.

Any increase in the number of Special Access circuits will require the issuance of a new ASR for the incremental capacity.

(A) Service Date Change Charge

ASR service dates may be changed, however a Service Date Change Charge will apply for each service date change after the plant test date of the original ASR.

For Special Access, except as specified below, the new service date may not exceed the original service date by more than 60 calendar days. If the requested service date is more than 60 calendar days after the original service date, the ASR will be canceled by the Company. Cancellation charges in 3.2.6 will apply and the ASR will be reissued with the new service date unless the customer indicates that billing for the service is to commence as in 3.2.6(A).

With the agreement of the Company, a new service date may be established that is prior to the original service date and the provisions in (E) will apply in addition to the Service Date Change Charge.



## FACILITIES FOR INTERSTATE ACCESS

3. ORDERING OPTIONS FOR FIA (Cont'd)3.2 Access Service Request (Cont'd)3.2.2 ASR Modifications (Cont'd)(A) Service Date Change Charge (Cont'd)

	<u>Rate</u>
<u>Jurisdiction</u>	
Alabama	\$37.51
Missouri	37.51

(B) Partial Cancellation Charge

Any decrease in the number Special Access circuits will be treated as a partial cancellation. A customer may cancel any number of Special Access circuits.

When a customer partially cancels the service ordered on an ASR, charges will apply as follows:

- (1) When an ASR for Special Access Service is partially canceled, on or after the Application Date, the charge will be determined by multiplying the total Special Access services nonrecurring charges for the canceled portion of the order by the number of business days elapsed since the Application Date and dividing that figure by the number of days in the service interval.
- (2) When a customer cancels part of an ASR for which billing has commenced as provided in 3.2.2(A) and 3.2.6(A), cancellation charges in 3.2.6(C)(3) will apply to that part of the ASR being canceled.

## FACILITIES FOR INTERSTATE ACCESS

3. ORDERING OPTIONS FOR FIA (Cont'd)3.2 Access Service Request (Cont'd)3.2.2 ASR Modifications (Cont'd)(C) Discontinuance of Service

A customer may discontinue FIA that is in service at any time. The request for discontinuance of service must be received by the Company at least two business days prior to the date on which service is to be disconnected and billing discontinued. The disconnect request may be submitted via the same method(s) used to place orders. The customer must notify the Company of a delay or cancellation in the discontinuance request prior to the disconnect date. The Company, where possible, will establish the disconnect date in accordance with such request. Billing and service will then continue until the new requested disconnect date. If a service is discontinued prior to the expiration of the Minimum Period in 3.2.4, the Minimum Period Charges in 3.2.5, may apply.

(D) Design Change Charge

The customer may request a design change to a pending ASR for Special Access Service. A design change is a change which requires engineering review. The regulations, rates and charges for a design change are in Section 5.6.1(F)(1) for Special Access Service, and are in addition to the regulations, rates and charges specified in this section.

## FACILITIES FOR INTERSTATE ACCESS

3. ORDERING OPTIONS FOR FIA (Cont'd)3.2 Access Service Request (Cont'd)3.2.2 ASR Modifications (Cont'd)

## (E) Expedited Order Charge

An Expedited Order Charge will apply when a customer requests a service date that is earlier than the standard interval date. If the company agrees to provide the service on an expedited basis, an expedited order charge will apply.

The request for an earlier service date may be received from the customer prior to the issuance of an access order, or after the access order has been issued but prior to the service date. When the request for expediting occurs subsequent to the issuance of the Access Order, a Service Date Change Charge as set forth in rate sections following also applies.

If the Company is subsequently unable to meet an agreed upon expedited service date, no Expedited Order Charge will apply unless the missed service date was caused by the customer.

In the event the customer cancels an expedited access order, the Expedited Order Charge will apply in addition to cancellation charges as described in 3.2.6 preceding.

An Expedited Order Charge will not apply to access service orders expedited for Company reasons.

The Expedited Order Charge will apply per access order, per business day improved from the standard interval date to the in-service date. The rate for an Expedited Order Charge is set forth following.

	<u>Rate</u>
Per Access Order, Per Business Day	
<u>Jurisdiction</u>	
Alabama	\$400.00
Missouri	400.00

3.2.3 Selection of Facilities for Access Service

Requests for a specific circuit is not an option of the customer except as provided for under Special Facilities Routing of FIA in Section 9.

## FACILITIES FOR INTERSTATE ACCESS

3. ORDERING OPTIONS FOR FIA (Cont'd)3.2 Access Service Request (Cont'd)3.2.4 Minimum Period

The Minimum Period for which Special Access and Monthly Optical Networking rate elements are provided and for which charges are applicable, is one month, except as follows:

- (A) The Minimum Period for Miscellaneous Services is in Section 6.
- (B) The Minimum Period for FIA provided under Special Construction provisions and for which charges are applicable in Brightspeed Local Operating Companies Tariff F.C.C. No. 5.
- (C) The Minimum Period for Program Audio Special Access is the minimum period for which rates are established in Section 5.7.
- (D) The minimum periods for Special Access DS3 Service are in Section 5.6.11.

3.2.5 Minimum Period Charges

When FIA are discontinued prior to the expiration of the Minimum Period, charges are applicable for the remaining month(s) and/or fraction thereof of the Minimum Period.

The Minimum Period Charge will be determined as follows:

- (A) For Special Access, other than DS3 Service, the charge is the applicable monthly rate for the service(s) as in 5.7. For Special Access DS3 Service, the charges are in Section 5.6.11.
- (B) For Optical Networking services, the charge is the applicable monthly rate for the service(s) as in 20(J).
- (C) For part-time or occasional Program Audio Special Access services, the rates in, 5.7 will apply.

Minimum Service Period requirements apply to all DS1 and DS3 services. Early Termination Liability not defined elsewhere for DS1 and DS3 will be 50% of the remaining months of the agreed upon term after the Minimum Service Period.

## FACILITIES FOR INTERSTATE ACCESS

3. ORDERING OPTIONS FOR FIA (Cont'd)3.2 Access Service Request (Cont'd)3.2.6 Cancellation of an ASR

(A)

A customer may cancel an Access Order for the installation of service at any time prior to notification by the Telephone Company that service is available for the customer's use. The cancellation date is the date the Telephone Company receives written or verbal notice from the customer that the order is to be canceled. The verbal notice must be followed by written confirmation within 10 days. If a customer or a customer's end user is unable to accept Access Service for any service except Ethernet Virtual Private Line (EVPL) within 30 calendar days of the latest agreed upon service date (i.e. firm order confirmation date), the customer has the choice of the following options:

- The Access Order will be canceled and charges set forth in (C) following will apply if the service has not been fully provisioned; or
- The Access Order will be completed and billing for the service will commence if the service has been fully provisioned or the customer has indicated that billing for the service should begin.

If a customer or a customer's end user is unable to accept Access Service for Ethernet Virtual Private Line (EVPL) within 5 business days of the latest agreed upon service date (i.e. firm order confirmation date), the customer has the choice of the following options:

- The Access Order will be canceled and charges set forth in (B) following will apply if the service has not been fully provisioned; or
- The Access Order will be completed and billing for the service will commence if the service has been fully provisioned or the customer has indicated that billing for the service should begin.

## FACILITIES FOR INTERSTATE ACCESS

3. ORDERING OPTIONS FOR FIA (Cont'd)3.2 Access Service Request (Cont'd)3.2.6 Cancellation of an ASR (Cont'd)

- (B) ASR costs are considered to have started when the Company incurs any cost in connection therewith or in preparation thereof which would not otherwise have been incurred. These costs include but are not limited to preliminary engineering, orders to suppliers, and other similar items of cost.
- (C) When a customer cancels an ASR for the installation of new service, or an ASR to modify existing service, charges will apply as follows:
  - (1) When an ASR for Special Access Service is canceled on or after the Application Date, the Cancellation Charge is calculated, on a per ASR basis, by multiplying the total nonrecurring charges for the quantity ordered by the number of business days elapsed since the Application Date and dividing that figure by the number of days in the service interval (i.e., the number of business days between the order date and the last day of the service date interval).

## FACILITIES FOR INTERSTATE ACCESS

3. ORDERING OPTIONS FOR FIA (Cont'd)3.2 Access Service Request (Cont'd)3.2.6 Cancellation of an ASR (Cont'd)

- (2) When a customer chooses to commence billing rather than cancel an ASR for these services specified in (A), the customer must submit an ASR prior to calendar day 31 from the original service date and request a service date change. The new service date may not exceed the original service date by more than 120 calendar days. Charges in 3.2.2(A) will only apply for each subsequent service date change request after calendar day 31, not to exceed 120 calendar days.

When a customer elects to commence billing, monthly recurring charges will begin accruing at calendar day 31 after the original service date. Upon completion of the ASR, the initial bill for the service will include these accrued charges and any additional nonrecurring charges in addition to billable charges specified in 2.4.1(C).

If the ASR is not completed within 121 calendar days of the original service date, the ASR will be canceled. Cancellation charges in (C)(2) will apply. In addition, the customer will be billed the accrued monthly recurring charges specified above plus any additional nonrecurring charges applicable for the Service. These charges will be computed commencing at day 31 after the original service date up to and including the cancellation date, not to exceed 90 days of service (120 days from the original service date). The Company will not reissue an ASR with a new service date beyond 121 calendar days. It will be the customer's responsibility to submit a new ASR for Switched or Special Access Service, as appropriate.

3.2.7 Reserved For Future Use3.2.8 Reserved For Future Use

## FACILITIES FOR INTERSTATE ACCESS

3. ORDERING OPTIONS FOR FIA (Cont'd)3.3 Access Service Requests For Services Provided By More Than One Telephone Company

Special Access Services provided by more than one telephone company are services where one end of the Special Transport facility is in the operating territory of one telephone company and the other end of the facility is in the operating territory of a different telephone company.

The ordering procedure for this service is in (A) and (B). The telephone company will notify the customer, identifying which ordering procedures will apply.

## (A) Single Company Billing

The telephone company receiving the ASR from the customer will arrange to provide the service and bill the customer as in 2.7.2.

## (B) Meet Point Billing

Each telephone company will provide its portion of the Switched Transport or Special Transport service within its operating territory to the meet point with the other telephone company(s). The BP will be determined by the telephone companies involved in providing the FIA service and listed in the ECA Tariff FCC No. 4.

For all Switched Access Services and all Special Access Services the order will be placed with the telephone company as specified in the Ordering and Billing Forum's Multiple Exchange Carrier Ordering and Design (MECOD) guidelines.



FACILITIES FOR INTERSTATE ACCESS

4. Reserved For Future Use

Effective: October 4, 2022

Original Page 5-1

## ACCESS SERVICE

5. SPECIAL ACCESS

Effective October 18, 2020, the Company offers Dedicated Ethernet, Switched Ethernet, and Wavelength Services on a private carriage basis and reserves the right to make individualized decisions regarding the provision of service to individual customers. The Company may negotiate the specific prices and terms for Dedicated Ethernet, Switched Ethernet, and Wavelength Services for each individual customer. Unless otherwise specified in this section, the general terms and conditions of this Service Guide apply to Dedicated Ethernet, Switched Ethernet, and Wavelength Services. <sup>[1]</sup>

As of August 1, 2017, Special Access Services were changed to a Competitive or Non-Competitive designation. Non-Competitive End-User Channel Terminations (EUCTs) are filed as part of Tariff F.C.C. No. 2 and remain under Price Cap Regulation. Other Special Access Services required to complete the circuit are covered by this ISG.

The following areas are deemed Non-Competitive for Special Access EUCTs and are covered by Tariff F.C.C. No. 2. Areas not listed are deemed Competitive for Special Access Services and are covered by this ISG.

ALABAMA					
Serving Wire Center	8-Digit CLLI Code	Serving Wire Center	8-Digit CLLI Code	Serving Wire Center	8-Digit CLLI Code
Abbeville	ABVLALXA	Echo	ECHOALXA	McKenzie	MCKNALXA
Andalusia	ANDSALXA	Forest Home	FRHMALXA	Midland City	MLCYALXA
Ariton	ARITALXA	Gantt	GNTTALXA	Newton	NWTNALXA
Banks	BNKSALXA	Greenville	GNVLALXA	Newville	NWVIALXA
Brundidge	BRNDALXA	Georgiana	GRGNALXA	Opp	OPP ALXA
Clio	CLIOALXA	Headland	HDLDALXA	Ozark	OZRKALXA
Daleville	DLVLALXA	Louisville	LSVLALXA	RedLevel	RDLVALXA

MISSOURI					
Serving Wire Center	8-Digit CLLI Code	Serving Wire Center	8-Digit CLLI Code	Serving Wire Center	8-Digit CLLI Code
Ava	AVA MOXA	Crane	CRANMOXA	Mansfield	MNFDMOXA

<sup>[1]</sup> Services include Ethernet Virtual Private Line, Metro Ethernet, Ethernet Transport, and Optical Wavelength.

## FACILITIES FOR INTERSTATE ACCESS

5. SPECIAL ACCESS (Cont'd)5.1 General

Special Access provides a transmission path to connect CDLs\* within a LATA for Interstate Telecommunications. Special Access provided to a customer may be connected directly to customer facilities, through Telephone Company Hub Wire Centers where bridging or multiplexing functions are performed, and/or may be connected to access facilities of another telephone company or companies in the joint provision of Special Access Service as well as may be connected to Switched Access as set forth in Section 4 of the Brightspeed Local Operating Companies Tariff F.C.C. No. 2..

The provision of Switched Access and Special Access in combination is normally for, but not limited to, the use of WATS or WATS-type Access. When Special Access is connected to Switched Access, the terms, conditions and rates for the facilities between the end user's CDL and the WATS Serving Office are as set forth in this section of the Interstate Service Guide; the terms, conditions and rates for the facilities between the WATS Serving Office and the IC's CDL, as well as the switching functionalities (e.g., end user access codes, screening) are as set forth in Section 4 of the Brightspeed Local Operating Companies Tariff F.C.C. No. 2..

Special Access can be provided in either analog or digital format. Analog formats are differentiated by spectrum and bandwidth. Digital formats are differentiated by bit rate. The specific types of Special Access provided are described in 5.2 following.

Special Access Service purchased from the provisions of this service guide may be commingled with unbundled network elements, where available, or unbundled network element combinations, where available, purchased pursuant to the Commission's Part 51 Interconnection Rules and in compliance with the Federal Communications Commission's Report and Order and Order on Remand and Further Notice of Proposed Rulemaking in CC Docket Nos. 01-338, 96-98 and 98-147, adopted February 20, 2003 and released August 21, 2003 (FCC 03-36). Unbundled elements and commingling are not available in designated rural Brightspeed Local Operating Companies where a 251 (f) exemption is in effect.

\* Company Centrex CO-like switches are considered to be CDLs for the purposes of this service guide.

## FACILITIES FOR INTERSTATE ACCESS

5. SPECIAL ACCESS (Cont'd)5.1 General (Cont'd)5.1.1 Rate Elements

Following are the basic rate elements which apply to Special Access Service:

Special Transport (described in 5.1.1(B) following)  
Special Transport Termination (described in 5.1.1(G) following)  
Channel Termination (f/k/a Special Access Line) (described in 5.1.1(C) following)  
Special Access Cross Connect (described in 20.4 following)  
Supplemental Features (described in 5.4 following)  
Multiplexing Arrangements (described in 5.5 following)

(A) Special Transport

- (1) The Special Transport rate element provides for the transmission facilities between the serving wire centers associated with two CDLs, between a serving wire center associated with a CDL and a WATS Service Office, between a serving wire center associated with a CDL and a Company Hub Wire Center or between two Company Hub Wire Centers.

The Special Transport element is distance sensitive, except for MetroLan, and varies with type of capability (i.e., analog or digital) and type of facility. Special Transport may be provided by more than one telephone company. The method of calculating applicable airline miles for rating purposes for Special Access is specified in 2.7 preceding.

MetroLAN Transport provides flat rate non-distance sensitive transport for DS1 bandwidth on fiber optic rings. The rate element associated with MetroLAN is a monthly recurring charge as set forth in 5.7.7(B).

- (2) Special Transport may be used in conjunction with Switched Access for the purpose of provisioning Originating Only, Terminating Only or Combined Originating/Terminating Access as set forth in Section 4.2.5(V) of the Brightspeed Local Operating Companies Tariff F.C.C. No. 2. Special Transport employed in this manner provides the FIA for the closed-end of the services between the wire center serving the end user's CDL where WATS Serving Office functions are not available and the WATS Serving Office.

When the necessary WATS Serving Office functions are not provided at the wire center which serves the end user's CDL, the Telephone Company will designate the wire center where the WATS Serving Office functions are available.

## FACILITIES FOR INTERSTATE ACCESS

5. SPECIAL ACCESS (Cont'd)5.1 General (Cont'd)5.1.1 Rate Elements(B) Channel Termination (f/k/a Special Access Line (SAL))

- (1) A Channel Termination provides the transmission facilities to a Customer Designated Location (CDL) or the facilities between a CDL and the serving wire center. This rate element varies by type of capability (i.e., analog or digital) and type of facility.

When a Voiceband Special Access service is ordered to be terminated at a customer's designated Interexchange Carrier's all-digital CDL which requires a minimum digital interface level of 1.544 Mbps, the Telephone Company will provide the required interface and assess the customer a Voiceband Channel Termination, for the facility between the all-digital CDL and its serving wire center. All other appropriate charges apply in addition to the Voiceband Channel Termination.

Channel Termination rates for DS3 offerings vary with the level of capacity, number of services and whether the interface provided is electrical or optical.

Installation of E1/DS1/DS3 Channel Terminations is as set forth in 5.6.1(E)(3). The applicable rates are the nonrecurring charge and monthly rate set forth per E1/DS1/DS3 Channel Termination installed.

The selection of a Terminating Option, as defined in 5.3, is required for terminating the network portion of a Channel Termination at a CDL. Terminating Options provide a clearly delineated interface which facilitates the design, isolation, and testing of the Special Access. For DS3/DS3C Special Access, the customer may specify either an electrical or optical interface as set forth in 3.1.1(F).

E1 service is provided only with an electrical interface, and is subject to the availability of suitable fiber optic facilities between the CDL and the serving wire center.

One Channel Termination charge applies per CDL at which the facility is terminated. This charge applies even if the facilities to the CDL do not transit a serving wire center; this charge also applies if the CDL and the serving wire center are co-located in a Telephone Company building. The Special Access Line charge used with a Switching Interface, as set forth in (2) below, is applicable only for the transmission facilities between the end user's CDL and the serving wire center of that location.

## FACILITIES FOR INTERSTATE ACCESS

5. SPECIAL ACCESS (Cont'd)5.1 General (Cont'd)5.1.1 Rate Elements(B) Channel Termination (Special Access Line (SAL)) (Cont'd)

- (2) A Channel Termination may be provided in conjunction with FGA, FGB, FGC, FGD, BSA-A, BSA-B, BSA-C and BSA-D Switched Access Service for the purpose of Originating Only, Terminating Only or Combined Originating and Terminating Access as set forth in Brightspeed Local Operating Companies Tariff F.C.C. No. 2 Section 4 A Switching Interface is required for the provision of this service as set forth in Brightspeed Local Operating Companies Tariff F.C.C. No. 2 Section 4. The Channel Termination provides the closed-end of the dedicated facilities between an end user's CDL and its serving wire center. This serving wire center may or may not be a WATS Serving Office. In those instances when the serving wire center is not a WATS Serving Office Special Transport is applicable to the nearest Telephone Company WATS Serving Office.

The Switched Access used in conjunction with the Channel Termination (Special Access Line) provides various standard switching functionalities and optional arrangements as set forth in Brightspeed Local Operating Companies Tariff F.C.C. No. 2 Section 4.

- (3) All Channel Terminations used with a Switching Interface are:
- provided with dial pulse address signaling or Dual Tone Multifrequency (DTMF) address signaling and either loop start or ground start supervisory signaling. The type of signaling is the option of the customer.
  - available as either a two-wire or four-wire Voiceband Special Access Service (i.e., 300-3000 Hz bandwidth). Each transmission path is provided at the option of the customer with transmission specifications as described in Section 7000 of the GTE Technical Interface Reference Manual.

All rules and regulations pertaining to Special Access are applicable to Channel Terminations (Special Access Lines) used with a Switching Interface. Rates and Charges are found in 5.7.5 for two-wire and four-wire Voiceband Special Access Lines.

## FACILITIES FOR INTERSTATE ACCESS

5. SPECIAL ACCESS (Cont'd)5.1 General (Cont'd)5.1.1 Rate Elements(B) Channel Termination (Special Access Line (SAL)) (Cont'd)

## (3) (Cont'd)

A customer may also order high capacity facilities from an end user's CDL to a Telephone Company Hub for the purpose of originating or terminating Channel Terminations used with a Switching Interface. High capacity to voice multiplexing will be required at the Hub. The customer will be required to submit an ASR for the high capacity facility and voice multiplexing. The customer will also be required to submit an ASR(s) for the individual Voiceband Channel Terminations specifying the channel facility assignment (CFA) for each service. This Hub may or may not be a WATS Serving Office. In those instances when the Hub is not a WATS Serving Office, Voiceband Special Transport is applicable as set forth in 5.1.1(A), for each individual Channel Termination used with a Switching Interface to the Telephone Company designated WATS Serving Office.

(C) Special Transport Termination(1) DS1, E1 and DS3

The Special Transport Termination rate element as set forth in 5.7, applies only to DS1, E1, Individual DS3 and System DS3 offerings and is in addition to the Special Transport rate element. Special Transport Termination provides the equipment and arrangements necessary to terminate the Special Transport facility at a serving wire center. One Special Transport Termination charge applies for the termination of each end of a Special Transport facility for E1, DS1 and DS3 (Individual and Systems) offerings.

(2) Fractional T1 Service (FT1) <sup>[1]</sup>

Fractional T1 Service Special Transport Termination must be ordered as Fractional Special Transport Termination in the same grouping (N x 56 Kbps or N x 64 Kbps where N = 2, 4, or 6) as the associated FT1 Channel Terminations (SALs).

(3) Ethernet Transport Service

The Special Transport Termination rate element as set forth in 5.7, applies only to Ethernet Transport offerings and is in addition to the Special Transport rate element. Special Transport Termination provides the equipment and arrangements necessary to terminate the Special Transport facility at a serving wire center. One Special Transport Termination charge applies for the termination of each end of a Special Transport facility for Ethernet Transport offerings.

<sup>[1]</sup> Effective February 1, 2020 Fractional Services are grandfathered. Availability to current customers is limited to circuits in service at existing locations.

## FACILITIES FOR INTERSTATE ACCESS

5. SPECIAL ACCESS (Cont'd)5.1 General (Cont'd)5.1.1 Rate Elements (Cont'd)(D) Supplemental Features

Supplemental Features may be added to a Special Access circuit to improve its quality or utility to meet specific communications requirements. These are not necessarily identifiable with specific facilities, but rather represent the end result in terms of performance characteristics which may be obtained. These characteristics may be obtained by using various combinations of facilities. Although the facilities necessary to perform a specified function may be installed at various locations along the path of the Special Access circuit, including the CDL, it will be provided for as a single rate element.

Examples of Supplemental Features that are available include, but are not limited to, bridging and conditioning. Each Supplemental Feature is described in 5.4, and rates are set forth in 5.7.

(E) Multiplexing Arrangements

Multiplexing provides for arrangements to convert a single higher capacity or bandwidth circuit for bulk transport to several lower capacity or bandwidth circuits. Multiplexing is only available at a Telephone Company designated Hub Wire Center arranged for multiplexing. All types of multiplexing may not be available at each Hub Wire Center. Refer to Section 5.6.6 for a description of Hub Wire Center. Descriptions for each type of multiplexing arrangements are provided in 5.5 following, and rates are set forth in 5.7 following.



FACILITIES FOR INTERSTATE ACCESS

5. SPECIAL ACCESS (Cont'd)

5.1 General (Cont'd)

5.1.2 Special Access Configurations

There are two types of facility configurations over which Special Access Services are provided – two-point and multipoint.

(A) Two-point Service

A two-point configuration is a circuit which is provided to connect two CDLs, either directly connected or through a Hub Wire Center where multiplexing functions are performed, or a CDL and a WATS Serving Office.

All Special Access offerings may be provided as a two-point configuration.

Applicable rate elements are:

- Channel Terminations (f/k/a Special Access Lines)
- Special Transport (when applicable)
- Special Transport Termination (when applicable)
- Supplemental Features (when applicable)
- Multiplexing Arrangements (when applicable)

The following diagram depicts a typical two-point service connecting two CDLs. The service is provided with the supplemental feature of Type C Conditioning:

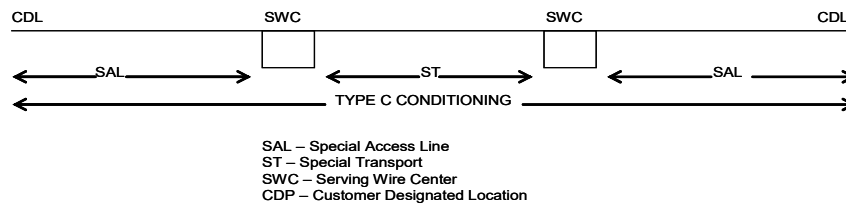

Applicable rate elements are:

- Channel Terminations (2 applicable)
- Special Transport ( per airline mile between SWCs)
- Supplemental Feature of Type C Conditioning (2 applicable)

In addition, a Special Access Surcharge, as set forth in 5.6.9 following, and a Message Station Equipment Recovery Charge, as set forth in 5.6.10 following may be applicable.

## FACILITIES FOR INTERSTATE ACCESS

5. SPECIAL ACCESS (Cont'd)5.1 General (Cont'd)5.1.2 Special Access Configurations (Cont'd)(B) Multipoint Service

A multipoint configuration is a circuit that is provided to connect three or more CDLs through a Company Hub Wire Center.

Only Voiceband, Program Audio, Digital Data Service facilities, and Miscellaneous Services where so designated, will be provided as multipoint configurations. There is no limitation on the number of mid-links, but the use of more than three mid-links in tandem may degrade the quality of the multipoint facilities. A mid-link is defined as the Special Transport facilities between Hub Wire Centers where the circuit is bridged and/or where circuit devices, such as loop transfer arrangement, are located.

Multipoint service is provided in the following manner.

- (1) Channel Termination per CDL to their respective serving wire centers.
- (2) Special Transport between serving wire centers associated with the CDLs and the Hub Wire Center.
- (3) Special Transport between Hub Wire Centers.
- (4) Supplemental Features: Bridging equipment for each bridging location and other Supplemental Features when applicable.
- (5) Multiplexing Arrangements when applicable.

FACILITIES FOR INTERSTATE ACCESS

5. SPECIAL ACCESS (Cont'd)

5.1 General (Cont'd)

5.1.2 Special Access Configurations (Cont'd)

(B) Multipoint Service (Cont'd)

The following diagram depicts a multipoint service connecting four CDLs via two customer specified Hub Wire Centers:

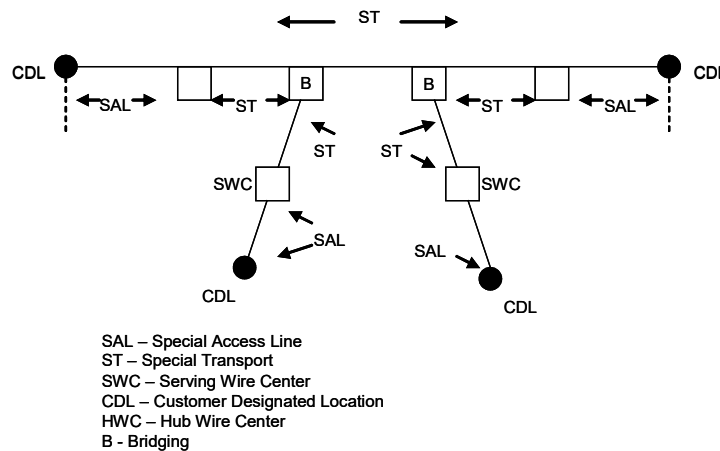

Applicable rate elements are:

- Channel Terminations (4 applicable)
- Special Transport (5 segments, per airline between SWCs and HWCs)
- Bridging (6 applicable, one per bridge port)

In addition, the Special Access Surcharge, as set forth in 5.6.9 following, and the Message Station Equipment Recovery Charge, as set forth in 5.6.10 may be applicable.

## FACILITIES FOR INTERSTATE ACCESS

5. SPECIAL ACCESS (Cont'd)5.1 General (Cont'd)5.1.3 Special Facilities Routing

A customer may request that the facilities used to provide Special Access Service be specially routed. The regulations, rates and charges for Special Facilities Routing (i.e., Avoidance and Diversity) are as set forth in Section 9 following.

5.1.4 Design Layout Report

The Company will provide to the customer the makeup of the Special Access provided under this service guide to aid the customer in designing its overall service. This information will be provided in the form of a Design Layout Report and will include the following:

- Cable gauge, length and loading.
- Specific pair of circuit assignment at the customer designated location.

The Design Layout Report will be provided to the customer within fourteen working days from the ASR Date. Updated reports will be reissued within fourteen working days whenever facilities provided to the customer are materially changed. Both the initial and updated Design Layout Reports will be provided to the customer at no charge.

5.1.5 Acceptance Testing

At the time of installation, the following test parameters apply:

- (A) For Voiceband services, acceptance testing will include tests for loss, 3-tone slope, DC continuity, operational signaling, C-notched noise, and C-message noise.

When the Interface Arrangement provides a four-wire voice transmission facility and the point of termination provides two-wire voice transmission (i.e., there is a four-wire to two-wire conversion at the point of termination) balance tests are also included in acceptance testing. When performing installation and acceptance testing, the Telephone Company will test the access service within the LATA.

On four-wire and effective four-wire circuits where the Network Channel Terminating Equipment (NCTE) has the capability of being remotely aligned, the Telephone Company may perform acceptance testing without a Telephone Company technician at the customer's premise. Should the customer request a technician be present at the customer's premise, additional charges will apply as set forth in Section 6.2(C). The applicable rates are in Section 6.2(G).

If the NCTE at the customer's premise does not have the capability of being aligned remotely, the additional charges will not apply. The Telephone Company will determine the type of NCTE placed at a customer's premise.

## FACILITIES FOR INTERSTATE ACCESS

5. SPECIAL ACCESS (Cont'd)5.1 General (Cont'd)5.1.5 Acceptance Testing (Cont'd)

- (B) For other analog services (i.e., Program Audio Services) and digital services acceptance testing will include tests for the parameters applicable to the service.

When the customer requests the performance of additional cooperative tests which are not required to meet these specified performance parameters, charges as set forth in 6.6 (B) following will apply. All test results will be made available to the customer upon request.

If acceptance tests are not started within 15 minutes after pre-service tests have been completed and the customer has been notified by the Company, additional charges may apply, as set forth in 6.2 following, unless the delay is caused by the Company.

## FACILITIES FOR INTERSTATE ACCESS

5. SPECIAL ACCESS (Cont'd)5.1 General (Cont'd)5.1.6 Ordering Conditions

Ordering conditions are set forth in detail in Section 3 preceding. Also included in that section, are other charges which may be associated with ordering Special Access (e.g., Service Date Change Charges, Cancellation Charges, etc.).

(A) Determination of Jurisdiction of Mixed Use Special Access Lines

When mixed interstate and intrastate Special Access Service is ordered, the jurisdiction will be determined as follows:

- (1) If the customer's estimate of the interstate traffic on the physically intrastate line involved constitutes 10% or less of the total traffic on that line, the line will be ordered and provided in accordance with the applicable rules and regulations of the appropriate intrastate tariff.
- (2) If the customer's estimate of the interstate traffic on the physically intrastate line involved constitutes more than 10% of the total traffic on that line, the line will be ordered and provided in accordance with the applicable rules and regulations of this service guide.
- (3) Lines in service on the effective date of this service guide certified to be jurisdictionally intrastate and having a maximum termination liability associated with them will not be assessed the termination liability. The customer must submit an ASR for each line changing jurisdiction no later than 90 days from the effective date of this service guide to have the termination liability waived.

(B) Special Access Jurisdictional Verification

If a billing dispute arises or a regulatory commission questions the customer's certification of the jurisdiction of the line the Company will ask the customer to provide the data used to determine the jurisdiction. The customer shall supply the data within 30 days of the Company's request. The customer shall keep records of system design and functions from which the jurisdiction can be ascertained and upon request of the Company make the records available for inspection as reasonably necessary for purposes of verification of the jurisdiction of the service

## FACILITIES FOR INTERSTATE ACCESS

5. SPECIAL ACCESS (Cont'd)5.2 Description of Special Access

Following are the types of Special Access offerings:

- Voiceband<sup>[1]</sup>
- Program Audio<sup>[1]</sup>
- High Capacity Digital
- Digital Data Service<sup>[1]</sup>
- Ethernet Transport
- Ethernet Virtual Private Line

Each type has its own characteristics, and are subdivided by one or more of the following:

- Transmission specifications
- Bandwidth
- Spectrum
- Speed (i.e., bit rate)

The Special Access offerings described below are comprised of a combination of the rate elements described in 5.1.1. The following descriptions indicate the most effective use for each facility. Customer use for purposes other than those indicated is limited only to the extent that such use must not harm the network. Further, the Company does not guarantee transmission performance beyond the parameters identified in the descriptions.

The transmission performance characteristics of each Special Access offering are stated in Section 7000 of the GTE Technical Interface Reference Manual. The Company will maintain existing transmission specifications on services installed prior to the effective date of this service guide, except that existing services with performance specifications exceeding the standards in the GTE Technical Interface Reference Manual will be maintained at the performance level specified in the manual. Where transmission performance characteristics are required other than those as stated in Section 7000 of the GTE Technical Interface Reference Manual, the Company will review, and where technically feasible, will develop rates and charges for the additional costs associated with provisioning the parameters. These rates and charges will be filed on an individual case basis in Section 5.9 and will apply in addition to all other applicable rates and charges.

The customer also has the option of ordering Voiceband and analog and digital high capacity facilities to a Telephone Company Hub for multiplexing to individual channels of a lower capacity or bandwidth. Descriptions of the types of multiplexing available at the Hubs, as well as the number of individual channels which may be derived from each type of facility, are set forth in 5.5. Additionally, the customer may specify supplemental features for the individual channels derived from the facility to further tailor the channel to meet specific communications requirements. Descriptions of the supplemental features available are set forth in 5.4.

For example, a customer may order a DS3 from a CDL to a Telephone Company Hub for multiplexing to 28 DS1 channels. The DS1 channels may be further multiplexed at the same or a different Hub to Voiceband channels or may be extended to other CDLs. Optional features may be added to either the DS1 or the Voiceband channels.

<sup>[1]</sup> Effective February 1, 2020 Voiceband, Program Audio and Digital Data Services are grandfathered. Availability to current customers is limited to circuits in service at existing locations.

## FACILITIES FOR INTERSTATE ACCESS

5 SPECIAL ACCESS (Cont'd)5.2 Description of Special Access (Cont'd)5.2.1 Voiceband <sup>[1]</sup>(A) Two-Wire Voiceband Facility

These facilities are unconditioned and are capable of transmitting voice or data signals within the frequency spectrum of approximately 300 Hz to 3000 Hz. These facilities are furnished on a two-point or multipoint basis and may be terminated two-wire or four-wire at the point of termination. They permit the simultaneous transmission of information in both directions over a circuit, but it is not possible to ensure independent information transmission in both directions. Supplemental features may be added, at applicable charges, to enhance the operational capabilities of these facilities.

(B) Four-Wire Voiceband Facility

These facilities are unconditioned and are capable of transmitting voice or data signals within the frequency spectrum of approximately 300 Hz to 3000 Hz. The facilities are furnished on a two-point or multipoint basis and may be terminated two-wire or four-wire at the point of termination. When terminated four-wire, they permit simultaneous independent transmission of information in both directions over a circuit. However, when terminated two-wire, simultaneous independent transmission cannot be supported. Supplemental features may be added, at applicable charges, to enhance the operational capabilities of these facilities.

<sup>[1]</sup> Effective February 1, 2020 Voiceband Services are grandfathered. Availability to current customers is limited to circuits in service at existing locations.



## FACILITIES FOR INTERSTATE ACCESS

5 SPECIAL ACCESS (Cont'd)5.2 Description of Special Access (Cont'd)5.2.2 Reserved for Future Use5.2.3 Program Audio <sup>[1]</sup>

These facilities are arranged and provided for the transmission of audio to be broadcast or which is to be used in connection with loudspeakers, wired music, closed circuit or recordings. Audio facilities are furnished for transmission in one direction. Audio facilities may be provided on a two-point or multipoint basis.

Program audio facilities are provided on either a full-time or part-time basis. The minimum periods for full-time and part-time service are set forth in Section 3.2.4. When a part-time program audio service is provided for ten or more consecutive days, it will be treated as a full-time service and rated accordingly. In no event will the charge for continuous part-time program audio exceed the amount that would have been charged in the same time period for full-time program audio facilities.

Listed below are the types of Program Audio facilities that are offered under this tariff.

(A) 200 to 3500 Hz

Facilities are generally acceptable for speech quality programming and are subject to use over limited distance due to transmission factors.

(B) 100 to 5000 Hz

Facilities are generally acceptable for music and provide good quality speech programming.

(C) 50 to 8000 Hz

Facilities for the provision of high fidelity music transmission.

(D) 50 to 15000 Hz

Facilities for the provision of high fidelity music transmission. Two such facilities may be conditioned, at applicable charges, for stereo operation.

<sup>[1]</sup> Effective February 1, 2020 Program Audio Services are grandfathered. Availability to current customers is limited to circuits in service at existing locations.

FACILITIES FOR INTERSTATE ACCESS

5 SPECIAL ACCESS (Cont'd)

5.2 Description of Special Access (Cont'd)

5.2.4 Reserved for Future Use

5.2.5 Reserved For Future Use

5.2.6 Reserved For Future Use

## FACILITIES FOR INTERSTATE ACCESS

5 SPECIAL ACCESS (Cont'd)5.2 Description of Special Access (Cont'd)5.2.7 High Capacity Digital

These facilities are two-point and are furnished between CDLs or between a CDL and a Telephone Company designated Hub Wire Center where multiplexing is offered. High Capacity facilities may be used to provide Special Access Lines as set forth in 5.1.1(C)(2). A High Capacity to Voice multiplexing arrangement, as described in Section 5.5, is required at the Hub Wire Center.

- (A) DS1 facilities provide for the transmission of isochronous bipolar serial data at a rate of 1.544 Mbps.
- (B) DS1C facilities provide for the transmission of isochronous bipolar serial data at a rate of 3.152 Mbps.
- (C) FT1 facilities <sup>[1]</sup> are furnished for the transmission of isochronous bipolar serial data and are available at transmission rate groupings of N x 56 Kbps or N x 64 Kbps where N equals 2, 4, or 6. FT1 channels are contiguous within the network and can be used to create a wideband circuit using customer provided equipment. When N x 64 FT1 is ordered in conjunction with DS1 service for multiplexing purposes, the DS1 must have Clear Channel Capability as described in 5.8.1 of the Brightspeed Local Operating Companies F.C.C. Tariff No. 2. FT1 Service at a rate of N x 64 Kbps will only be provided where Clear Channel Capability is available in the network. Where Clear Channel Capability is not available, N x 56 Kbps service can be provided in lieu of N x 64 Kbps.
- (D) Reserved for Future Use
- (E) DS3 facilities provide for the transmission of isochronous bipolar serial data at a rate of 44.736 Mbps. The Telephone Company will provide either an interface with Telephone Company electronics (electrical) or without Telephone Company electronics (optical) at the option of the customer. Ordering conditions are set forth in 3.1.1(F). EIS is not available with DS3 services provided with an optical interface.
- (F) DS3C facilities provide for the transmission of isochronous bipolar serial data at a rate of 89.472 Mbps. The Telephone Company will provide an optical interface with this service unless the service is provided via microwave, in which case an electro-magnetic interface is provided, or unless the customer requests an electrical interface. Ordering conditions are set forth in 3.1.1.

<sup>[1]</sup> Effective February 1, 2020 Fractional T1 Services are grandfathered. Availability to current customers is limited to circuits in service at existing locations.

## FACILITIES FOR INTERSTATE ACCESS

5 SPECIAL ACCESS (Cont'd)5.2 Description of Special Access (Cont'd)5.2.8 Reserved for Future Use5.2.9 Digital Data Service <sup>[1]</sup>

Facilities for Digital Data Service are furnished for the simultaneous two-way transmission of synchronous data and are available at transmission speeds of: 2.4 Kbps, 4.8 Kbps, 9.6 Kbps, 19.2 Kbps, 56 Kbps or 64 Kbps. Digital Data facilities may be provided on a two-point or multipoint basis.

5.2.10 Miscellaneous Special Access Services

A description of each service provided under Miscellaneous Special Access Services, along with the rates is set forth in 5.8 following. Other Special Access rate elements may apply in addition to those found in 5.8.

<sup>[1]</sup> Effective February 1, 2020 Digital Data Services are grandfathered. Availability to current customers is limited to circuits in service at existing locations.

## FACILITIES FOR INTERSTATE ACCESS

5. Special Access Service (Cont'd)5.2 Description of Special Access (Cont'd)5.2.11 Ethernet Transport(A) Basic Service Description

Ethernet Transport (ET) service is a high speed data transport service that provides point-to-point transmissions of customers' data communications that customers deliver to the Company in a fast packet based ethernet protocol. ET is available at eleven transport speeds: 10 Mbps, 20 Mbps, 50 Mbps, 100 Mbps, 150 Mbps, 300 Mbps, 450 Mbps, 600 Mbps, 1 Gbps, 2.5 Gbps and 10 Gbps.

ET is provided on a month-to-month basis or for periods of one, three or five years. When a customer orders ET, the customer and the Company will work cooperatively to plan, engineer, provision and manage the ET circuits. ET is only available where facilities and operating conditions exist.

(1) Ethernet Transport Special Access Line (SAL)

ET SALs may be used to connect the following:

- a customer designated premises to the serving wire center of that premises.

The ET SAL rate element may vary based on distance. The mileage used to determine the monthly rate for SALs located outside a Company Central Office is the airline distance between the customer's designated premises and the Company serving wire center. The mileage measurement is determined by utilizing exchange maps and mileage tables located in designated Company offices for such purposes.

ET SALs provided to a customer's designated premises will be installed in a single, common space under Company control. An ET SAL may not be split between premises or terminated in multiple locations within a premises. The customer must provide suitable floor space, environmental controls and non-switched AC power to support the ET SAL at the customer's premises location.

## FACILITIES FOR INTERSTATE ACCESS

5. Special Access Service (Cont'd)5.2 Description of Special Access (Cont'd)5.2.11 Ethernet Transport (Cont'd)(A) Basic Service Description (Cont'd)(2) Ethernet Transport Special Transport

Ethernet Transport Special Transport provides transport between two Company serving wire centers. Air mileage is measured using V&H coordinates between the Company serving wire centers. The ET Special Transport rates are made up of the Special Transport (per mile) rate and the Special Transport Termination rate.

Rates and charges for ET are set forth in 5.7.18 following.

(3) Technical Specifications

The technical specifications for the protocols transmitted over Ethernet Transport service are delineated in the following technical publications:

<u>Protocol</u>	<u>Publication</u>
10 Mbps Ethernet	ANSI / IEEE X3.802.3
100 Mbps Ethernet	ANSI / IEEE X3.802.3u
1 Gbps Ethernet	ANSI / IEEE X3.802.3z

FACILITIES FOR INTERSTATE ACCESS

5. Special Access Service (Cont'd)

5.2 Description of Special Access (Cont'd)

5.2.11 Ethernet Transport (Cont'd)

(A) Basic Service Description (Cont'd)

(4) Service Components

The following diagram depicts a generic view of the components of Ethernet Transport service:

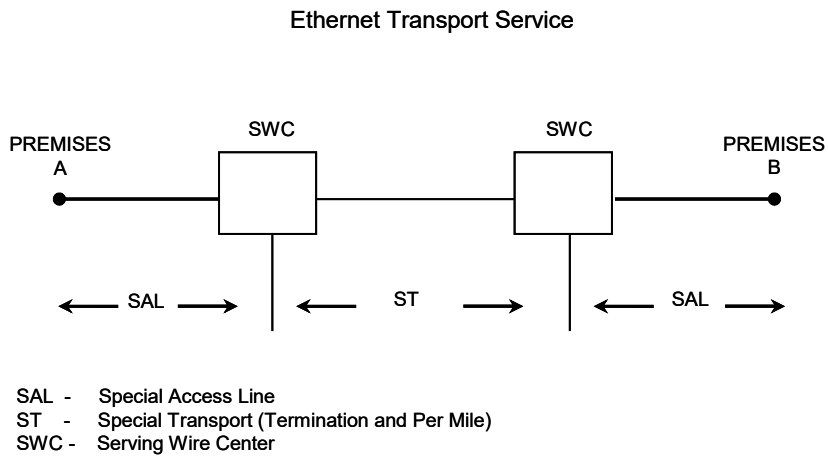

## FACILITIES FOR INTERSTATE ACCESS

5. Special Access Service (Cont'd)5.2 Description of Special Access (Cont'd)5.2.11 Ethernet Transport (Cont'd)(B) Channel Interface and Network Channel Codes

<u>Code</u>	<u>Option</u>	<u>Description</u>
KD	- A	Ethernet at 10 Mbps, full duplex LAN
	- B	Ethernet at 10 Mbps, half duplex LAN
KE	- A	Ethernet at 100 Mbps, full duplex LAN
	- B	Ethernet at 100 Mbps, half duplex LAN
KF	- L	Ethernet at 1000 Mbps, LAN
KR	- A1	Ethernet Rate-Adjustable 1 Gbps, 100 Mbps, full duplex
	- A3	Ethernet Rate-Adjustable 1 Gbps, 300 Mbps, full duplex
	- A6	Ethernet Rate-Adjustable 1 Gbps, 600 Mbps, full duplex
	- AB	Ethernet Rate-Adjustable 1 Gbps, 150 Mbps, full duplex
	- AK	Ethernet Rate-Adjustable 1 Gbps, 450 Mbps, full duplex
KQ	- A2	Ethernet Rate-Adjustable 1 Gbps, 20 Mbps, full duplex
	- B2	Ethernet Rate-Adjustable 1 Gbps, 20 Mbps, half duplex
	- A5	Ethernet Rate-Adjustable 1 Gbps, 50 Mbps, full duplex
	- B5	Ethernet Rate-Adjustable 1 Gbps, 50 Mbps, half duplex



## FACILITIES FOR INTERSTATE ACCESS

5. Special Access Service (Cont'd)5.2 Description of Special Access (Cont'd)5.2.12 Ethernet Virtual Private Line(A) Basic Service Description

Ethernet Virtual Private Line (EVPL) service provides the ability to order Ethernet service where a single customer connection can support multiple applications with varying Quality of Service (QoS). EVPL is available at transport speeds of: 10 Mbps, 100 Mbps, 1000 Mbps (1 Gbps) and 10000 Mbps (10 Gbps).

EVPL is provided on a monthly basis, under a Term Discount Plan for periods of one, two, three or five years as set forth in 5.6.20(C) following or under a Fixed Rate Term Plan for a period of seven years or as specified and set forth in 5.6.20(D) following. When a customer orders EVPL, the customer and the Company will work cooperatively to plan, engineer, provision and manage the EVPL circuits. EVPL is only available where facilities and operating conditions exist.

EVPL provides customer capabilities to support different Quality of Service (QoS) (i.e., Gold, Silver and Best Effort) as described in (5) following over the same connection and offers customers increased flexibility to match bandwidth to their real needs for voice and data applications on each connection. The customer orders the portion of their EVPL bandwidth that will be allocated for each quality of service.

For each EVPL, the customer's bandwidth will be rate limited or policed to a fixed speed for each QoS level specified in the QoS profile selected for the Ethernet Virtual Connection (EVC).

EVPL service is available 24 hours per day, 7 days per week, except for preventive maintenance. Due to the nature of EVPL it will be necessary to perform preventive maintenance and software updates. This will mean that the EVPL service will be unavailable during the period of time when preventive maintenance is being performed. The Company will provide notice to customers of such maintenance.

Rates and charges for EVPL are set forth in 5.7.20 and 5.7.21 following.

## FACILITIES FOR INTERSTATE ACCESS

5. Special Access Service (Cont'd)5.2 Description of Special Access (Cont'd)5.2.12 Ethernet Virtual Private Line (Cont'd)(A) Basic Service Description (Cont'd)(1) User to Network (UNI) Port Connection

The User to Network (UNI) Port Connection is the physical interface or port that is the demarcation between the customer and the service provider. The UNI Port Connection is always provided by the service provider. The UNI Port Connection in a Carrier Ethernet Network (CEN) is a physical Ethernet Interface at operating speeds of 10 Mbps, 100 Mbps, 1000 Mbps (1 Gbps) and 10000 Mbps (10 Gbps).

(2) Network to Network (NNI) Port Connection

The Network to Network (NNI) Port Connection is the interface between distinct CENs operated by one or more customers. The NNI Port Connection is available at operating speeds of 10 Mbps, 100 Mbps, 1000 Mbps (1 Gbps) and 10000 Mbps (10 Gbps).

(3) External Network to Network (E-NNI) Port Connection

The External Network to Network (E-NNI) Port Connection is the interface between two Operator CENs that are operated separately. The E-NNI Port Connection is available at operating speeds of 1000 Mbps (1 Gbps) and 10000 Mbps (10 Gbps).

(4) Operator Virtual Connection (OVC)

The OVC is associated with an ENNI port type. Customers may order more than one OVC per port. The Company will bill a monthly OVC charge per port that the OVC terminates on. The OVC is available at speeds of 3 Mbps, 5 Mbps, 7 Mbps, 10 Mbps, 20 Mbps, 30 Mbps, 40 Mbps, 50 Mbps, 60 Mbps, 70 Mbps, 80 Mbps, 90 Mbps, 100 Mbps, 200 Mbps, 300 Mbps, 400 Mbps, 500 Mbps, 600 Mbps, 700 Mbps, 800 Mbps, 900 Mbps and 1000 Mbps (1 Gbps).

## FACILITIES FOR INTERSTATE ACCESS

5. Special Access Service (Cont'd)5.2 Description of Special Access (Cont'd)5.2.12 Ethernet Virtual Private Line (Cont'd)(A) Basic Service Description (Cont'd)(5) Ethernet Virtual Connection (EVC)

The EVC connects two or more customer UNI port connections. The EVC prevents data transfer between locations that are not part of the same EVC. The EVC is available at speeds of 3 Mbps, 5 Mbps, 7 Mbps, 10 Mbps, 20 Mbps, 30 Mbps, 40 Mbps, 50 Mbps, 60 Mbps, 70 Mbps, 80 Mbps, 90 Mbps, 100 Mbps, 200 Mbps, 300 Mbps, 400 Mbps, 500 Mbps, 600 Mbps, 700 Mbps, 800 Mbps, 900 Mbps and 1000 Mbps (1 Gbps).

EVC reconfigurations performed by the core network under normal operating conditions should occur without packet loss. An EVC is capable of interconnecting with other EVCs of equal bandwidth in the same metropolitan area.

Two EVCs between the same two end points may be purchased by the customer in a configuration utilizing different switching locations for each EVC in order to provide a level of network diversity. In the event of interruption of the network, recovery of at least one EVC will be re-established and data flow will be restored in <50 ms.

(6) Quality of Service

The Quality of Service (QoS) is the ability to provide different priority to the various applications of EVPL in order to guarantee a certain level of performance to a data flow. The QoS is available at speeds of 3 Mbps, 5 Mbps, 7 Mbps, 10 Mbps, 20 Mbps, 30 Mbps, 40 Mbps, 50 Mbps, 60 Mbps, 70 Mbps, 80 Mbps, 90 Mbps, 100 Mbps, 200 Mbps, 300 Mbps, 400 Mbps, 500 Mbps, 600 Mbps, 700 Mbps, 800 Mbps, 900 Mbps and 1000 Mbps (1 Gbps) and is available in 3 different priority levels described following:

- Gold: The Gold QoS is supported by a low latency queue. The Low Latency Queuing (LLQ) feature in the Ethernet network is used for support of real-time service and is configured for strict priority queuing allowing latency sensitive applications, such as voice, to be sent first. Gold QoS will be marked for expedited handling within the EVPL network.

## FACILITIES FOR INTERSTATE ACCESS

5. Special Access Service (Cont'd)5.2 Description of Special Access (Cont'd)5.2.12 Ethernet Virtual Private Line (Cont'd)(A) Basic Service Description (Cont'd)(6) Quality of Service (Cont'd)

- Silver: The Silver QoS supports interactive video applications. The Silver QoS is policed to a maximum bandwidth.
- Best Effort: This QoS is the default QoS for other traffic that is not defined as Gold or Silver. Traffic that does not match any other QoS will be mapped as Best Effort. Traffic with the Best Effort QoS will have the lowest priority on the network and will support lower priority data applications, such as email and file transfer protocol (FTP).

EVPL reporting is available to customers who purchase the Gold or Silver QoS EVPL service. EVPL reporting allows customers to view their EVPL network via the use of a web interface and secure connection. EVPL reporting provides alarm surveillance, service level agreement reporting and performance report for the various network components that comprise the customer's EVPL network.

(7) OAM EVC

The Operations, Administration and Maintenance (OAM) EVC order in increments of 5Mbps only and may order up to 5 each. The OAM EVC is available for the High Volume Based Plan only. The OAM EVC will be used solely by the customer for the purposes of their own testing of traffic to determine the operational capability of the circuit that is provisioned to/from a specific location.

## FACILITIES FOR INTERSTATE ACCESS

5. Special Access Service (Cont'd)5.2 Description of Special Access (Cont'd)5.2.12 Ethernet Virtual Private Line (Cont'd)(A) Basic Service Description (Cont'd)(8) EVPL Reconfiguration

An EVPL Reconfiguration charge will apply for each Ethernet Virtual Connection (EVC) or Quality of Service (QoS) established initially or when the customer requests the EVC or QoS be reconfigured after the initial set up. The EVPL Reconfiguration charge is in addition to all applicable charges associated with the new configuration.

(9) CO NNI Arrangement (ICO Trunking Arrangement)

In some cases, the Company and another Incumbent Local Exchange Carrier (ILEC, sometimes also referred to as an Independent Company or ICO) may agree to jointly provide an Ethernet service where such service will be provided to locations in both the Company's and the other ILEC's serving territories. In such cases, the Company and the other ILEC may mutually agree to meet at a location (i.e., customer designated point of interconnection within the LATA or equivalent area) utilizing facilities suitable for delivery of EVPL service.

The rates and charges for EVPL are applicable for the Company provided portion of such service. The Company is responsible for the ordering, provisioning, billing and maintenance of EVPL up to the customer designated point of interconnection within the LATA or equivalent area.

Service Level Agreement (SLA) credits in 5.6.20(E), following, will apply for the portion of the service the Company provides.

SLA reporting does not include traffic to or from any ICO NNI Trunking Arrangement

The ICO NNI Arrangement provides a shared trunk connection from the EVPL Switch to the customer designated point of interconnection within the LATA or equivalent area that is then connected to the ILEC (ICO) Ethernet switch, for purposes of providing multiple Ethernet Virtual Connections (EVCs) for the same or different customers over this shared facility. The ICO Trunk Connection charge is applied to each EVC that is transported on the ICO NNI Trunking Arrangement.

## FACILITIES FOR INTERSTATE ACCESS

5. Special Access Service (Cont'd)5.2 Description of Special Access (Cont'd)5.2.12 Ethernet Virtual Private Line (Cont'd)(A) Basic Service Description (Cont'd)(10) Channel Mileage/ICO NNI Additional Mileage

Channel mileage and additional mileage charges are applicable only to the Bandwidth Based Plan. Channel mileage charges apply to EVPL service based on the service speed and when the total distance associated with the data channel exceeds 65 miles between Company serving wire centers. EVPL channel mileage provides transport between two Company serving wire centers. Air mileage is measured using V&H coordinates between the Company serving wire centers. The EVPL channel mileage rate element will be applied on a per mile basis for each mile exceeding the first 65 miles of transport.

The Additional Mileage charge is based on the distance measured from the EVPL switch to the customer designated point of interconnection within the LATA or equivalent area for mileage and is applicable to each ICO Trunking Arrangement EVC transported across the shared facility. Rates and charges are set forth in 5.7.21.

## FACILITIES FOR INTERSTATE ACCESS

5. Special Access Service (Cont'd)5.2 Description of Special Access (Cont'd)5.2.12 Ethernet Virtual Private Line (Cont'd)(A) Basic Service Description (Cont'd)

For each EVPL arrangement, the customer must decide the mix of applications that will be supported on that EVPL, the QoS mix that the EVPL must support and the bandwidth to be assigned for each QoS. The customer's bandwidth will be limited to the fixed speed associated with each QoS level. Therefore, total bandwidth available to support transmission of a specific QoS will depend upon the size of the customer's EVPL and the specific QoS bandwidth the customer selected for that EVPL.

A customer may select different QoS profiles for different EVPL connections that share the same network LAN, or EVPL network arrangement. However, technical limitations exist that limit the total number of different QoS profiles that can be utilized in a single EVPL network arrangement.

(B) Technical Specifications

The technical specifications for the protocols transmitted over EVPL service are delineated in the following technical publications:

<u>Protocol</u>	<u>Publication</u>
10 Mbps Ethernet	ANSI / IEEE X3.802.3
100 Mbps Ethernet	ANSI / IEEE X3.802.3u
1 Gbps Ethernet	ANSI / IEEE X3.802.3z
	IETF RFC 4090
	ITU-TY.1731

FACILITIES FOR INTERSTATE ACCESS

5. Special Access Service (Cont'd)

5.2 Description of Special Access (Cont'd)

5.2.12 Ethernet Virtual Private Line (Cont'd)

(C) Service Components

The following diagrams depict generic views of the components of EVPL service.

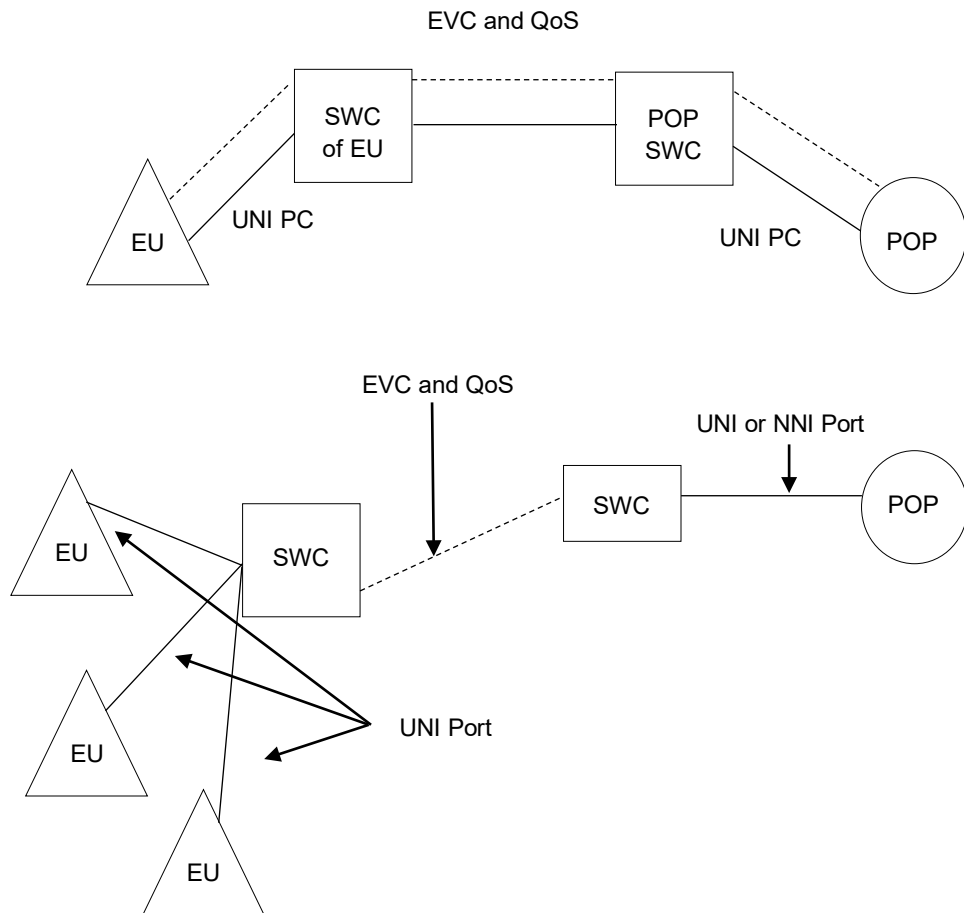



## FACILITIES FOR INTERSTATE ACCESS

5. Special Access Service (Cont'd)5.2 Description of Special Access (Cont'd)5.2.13 Optical Wavelength Service (OWS)

Optical Wavelength Service (OWS) is a high speed data transport service that provides point-to-point transmissions of data communications that customers deliver to the Company utilizing shared Dense Wave Division Multiplexing (DWDM) technology available at speeds of: 1 Gbps, 2.5 Gbps, 10 Gbps, 40 Gbps and 100 Gbps.

OWS is provided on a month-to-month basis or for periods of one, three or five years. When a customer orders OWS, the customer and the Company will work cooperatively to plan, engineer, provision and manage the OWS circuits. OWS is only available where facilities and operating conditions exist.

.There are two basic rate categories which apply to Special Access Service:

- Channel Terminations
- Channel Mileage

(A) OWS Channel Termination

OWS channel terminations may be used to connect the following:

- a customer designated premises to the serving wire center of that premise.

The OWS channel termination rate element may vary based on distance. The mileage used to determine the monthly rate for channel terminations located outside a Company Central Office is the airline distance between the customer's designated premises and the Company serving wire center. The mileage measurement is determined by utilizing exchange maps and mileage tables located in designated Company offices for such purposes

OWS channel terminations provided to a customer's designated premises will be installed in a single, common space under Company control. One Channel Termination charge applies per customer designated premises at which the channel is terminated. This charge will apply even if the customer designated premises and the serving wire center are collocated in a Company building. An OWS channel termination may not be split between premises or terminated in multiple locations within a premise. The customer must provide suitable floor space, environmental controls and non-switched AC power to support the OWS channel termination at the customer's premises location. The Channel Termination is the interface located at the Central Office that allows OWS to connect to the following Company services: SONET, ET, or EVPL.

## FACILITIES FOR INTERSTATE ACCESS

5. Special Access Service (Cont'd)5.2 Description of Special Access (Cont'd)5.2.13 Optical Wavelength Service (OWS) (Cont'd)(B) OWS Channel Mileage

OWS channel mileage provides transport between two Company serving wire centers. Air mileage is measured using V&H coordinates between the Company serving wire centers. The OWS channel mileage rates are made up of the Channel Mileage Facility (per mile) rate and the Channel Mileage Termination (fixed) rate.

Available in the following interfaces:

- 10 Gbit LAN Channel
- 10 Gbit WAN Channel
- Gbit Ethernet Channel
- SONET Channel (OC3, OC12, OC48, OC192)
- 10.709 Gbit OTU2 Channel
- 2.666 Gbit OTU1 Channel
- 111.810 Gbit OTU4 Channel
- 100GbE Ethernet Channel
- 43.018 Gbit OTU3 Channel

## FACILITIES FOR INTERSTATE ACCESS

5. Special Access Service (Cont'd)

## 5.3 Description of Terminating Options

Terminating Options provide a clearly delineated interface between Company and customer facilities at the point of termination at the CDL. Terminating Options facilitate the design, isolation, and testing of the Special Access. The description of each Terminating Option defines the most effective use of the Terminating Option. The technical parameters of each type of associated interface are set forth in Section 7000 of the GTE Technical Interface Reference Manual. Although a customer is not restricted from alternate applications, except where such application is harmful to the network, the Company cannot guarantee technical performance for other than the applications stated below. Terminating Options are nonchargeable.

5.3.1 Reserved For Future Use5.3.2 Voice Grade <sup>[1]</sup>(A) Two-Wire Voice Grade, Non-Data, Without Signaling

This option provides a two-wire interface to a customer and terminates an effective two-wire facility furnished for voice transmission only. Customer provided signaling must be limited to tones in the voice band. Customer provided voiceband signaling equipment must limit transmission power to 0.0 dBm peak and -13 dBm average power over a three-second period.

(B) Four-Wire Voice Grade, Non-Data, Without Signaling

This option provides a four-wire interface to the customer terminal equipment and terminates an effective four-wire facility furnished for voice transmission only. Customer provided signaling must be limited to tones in the voiceband. Customer provided voice band signaling equipment must limit transmission power to 0.0 dBm peak and -13 dBm average power over a three-second period.

[1] Effective February 1, 2020 Voice Grade Services are grandfathered. Availability to current customers is limited to circuits in service at existing locations.

## FACILITIES FOR INTERSTATE ACCESS

5. Special Access Service (Cont'd)

## 5.3 Description of Terminating Options

5.3.2 Voice Grade <sup>[1]</sup> (Cont'd)(C) Voice Grade Data Termination

This option provides a two-wire or four-wire transmission interface to a customer's private line data modem and terminates an effective four-wire facility furnished for voiceband data transmission.

(D) Two-Wire Voice Grade Station Connecting Facility Termination

This option provides a means to terminate an effective two-wire facility or an effective four-wire facility with a two-wire customer interface on a telephone, key system, PBX, ACD, or similar equipment. This option is normally used to terminate facilities that furnish foreign central office service, the station end of PBX off premises service, or private switched service network access lines. The option provides both the transmission and loop signaling functions normally associated with these services. The option is also used to terminate facilities arranged with automatic ringdown signaling. This option provides the loop and ringdown signaling with the facility.

(E) Four-Wire Voice Grade Station Connecting Facility Termination

A terminating option similar to (D) preceding used to terminate effective four-wire foreign central office service. The option provides a four-wire transmission interface to the customer terminal equipment and the loop signaling function normally associated with these services. This option provides the loop and ringdown signaling with the facility.

(F) Two-Wire Station Connecting Facility Termination for the Open End of an Off Premises PBX Extension

Terminating options are available depending on the signaling range of the PBX (or similar system) as defined in Part 68 of the FCC Rules and Regulations. Type 1 is an option requiring range extension equipment at the CDL. Type 2 is an option with no range extension equipment at the CDL. If needed, the loop signaling range equipment for Type 1 must be specifically specified, see Section 5.4.4 following for available arrangements.

(G) Dial Repeating Tie Trunk Termination

Two network terminating options are provided for terminating effective four-wire transmission facilities used to furnish dial repeating tie trunk services. These options are described in terms of the interface they provide to a PBX (or similar system).

- (1) A Type I tie line termination provides the customer with a two-wire transmission interface and includes either two-wire or four-wire E&M type signaling. Transmission and signaling interface options available are described in Part 68 of the FCC Rules and Regulations. This option provides the E&M type signaling with the facility.

<sup>[1]</sup> Effective February 1, 2020 Voice Grade Services are grandfathered. Availability to current customers is limited to circuits in service at existing locations.

## FACILITIES FOR INTERSTATE ACCESS

5. Special Access Service (Cont'd)

## 5.3 Description of Terminating Options

5.3.2 Voice Grade<sup>[1]</sup> (Cont'd)(G) Dial Repeating Tie Trunk Termination (Cont'd)

- (2) A Type III tie line termination provides the customer with a four-wire transmission interface and includes either two-wire or four-wire E&M type signaling. Transmission and signaling options available are described in Part 68 of the FCC Rules and Regulations. This option provides the E&M signaling with the facility.

5.3.3 Program Audio<sup>[1]</sup>(A) 200 to 3500 Hz

Provides standard program audio interface levels and impedance matching to two-wire network facilities.

(B) 100 to 5000 Hz, 50 to 8000 Hz, and 50 to 15000 Hz

Provides standard program audio interface levels, circuit equalization and impedance matching to two-wire network facilities.

5.3.4 Reserved for Future Use5.3.5 Reserved for Future Use5.3.6 Reserved for Future Use

<sup>[1]</sup> Effective February 1, 2020 Voice Grade and Program Audio Services are grandfathered. Availability to current customers is limited to circuits in service at existing locations.

## FACILITIES FOR INTERSTATE ACCESS

5. Special Access Service (Cont'd)

## 5.3 Description of Terminating Options

5.3.6 High Capacity Digital(A) High Capacity Digital DS1

Provides a High Capacity Digital DS1 Special Access interface for use in providing simultaneous two-way transmission of isochronous bipolar serial data signals at the rate of 1.544 Mbps.

(B) High Capacity Digital DS1C

Provides a High Capacity Digital DS1C Special Access interface for use in providing simultaneous two-way transmission of isochronous bipolar serial data signals at the rate of 3.152 Mbps.

(C) Fractional T1 Service <sup>[1]</sup>

Provides a DS1 Special Access interface for use in providing simultaneous two-way transmission of isochronous bipolar serial data signals and is limited to groupings of N x 56 Kbps or N X 64 Kbps where N equals 2, 4, or 6.

(D) Reserved for Future Use(E) High Capacity Digital DS3

Provides a High Capacity Digital DS3 Special Access interface for use in providing simultaneous two-way transmission of isochronous bipolar serial data signals at the rate of 44.736 Mbps. The Telephone Company will provide either an interface with Telephone Company electronics (electrical) or an interface without Telephone Company electronics (optical) as specified by the customer. EIS is not available with DS3 services provided with an optical interface. Ordering conditions are set forth in 3.1.1(F).

(F) High Capacity Digital DS3C

Provides a High Capacity Digital DS3C Special Access interface for use in providing simultaneous two-way transmission of isochronous bipolar serial data signals at the rate of 89.472 Mbps. The Telephone Company will provide an optical interface with this service unless the service is provided via microwave, in which case, an electromagnetic interface is provided, or unless the customer requests an electrical interface. Ordering conditions are set forth in 3.1.1(F).

5.3.7 Digital Data Service (DDS) <sup>[1]</sup>

Provides DDS Special Access interface for use in providing simultaneous two-way transmission of sequential bipolar data signals at transmission speeds of 2.4 Kbps, 4.8 Kbps, 9.6 Kbps, 19.2 Kbps, 56 Kbps or 64 Kbps.

<sup>[1]</sup> Effective February 1, 2020 Fractional T1 and Digital Data Services are grandfathered. Availability to current customers is limited to circuits in service at existing locations.

## FACILITIES FOR INTERSTATE ACCESS

5. Special Access Service (Cont'd)5.4 Description of Supplemental Features<sup>[1]</sup>

Supplemental Features are items which can be added to a Special Access service to provide enhanced capabilities or improve its utility. References to specific uses or Special Access types indicate the most effective use for each Supplemental Feature. Customer use for other purposes or with other Special Access types is limited only to the extent that such use must not harm the network. Further, the Telephone Company does not guarantee functional operation of Supplemental Features for these alternate applications.

Listed below are the Supplemental Features that are offered under this service guide.

5.4.1 Bridging

Bridging is the function of connecting three or more CDLs in a multipoint arrangement. Listed below are those bridging services offered under this tariff.

(A) MultiPoint Data Bridging

This feature provides the capability to derive a multipoint data circuit from a single facility and is normally provided on Voiceband facilities provided for transmission of data signals. This function is provided on a per port basis. Polled multipoint data circuits are a typical application of this feature.

(B) Voice Conference Bridging

Bridging arrangement to connect multiple Voiceband facilities in order that a voice frequency input signal from any location will be reproduced at the output of all other circuit locations. This function is provided on a per port basis.

(C) Alarm Distribution Bridging

Provides polling type bridging capabilities, band splitting filters and conversion of four-wire common terminations up to a capacity of 40 two-wire terminations. This function is offered as two tariff elements. The first element provides all shelving and common equipment for a capacity of 40 two-wire terminations. The second element provides a two-wire port. One common equipment rate element will apply to accommodate up to 40 two-wire terminations. One two-wire port charge will apply to each two-wire Special Access Line terminated in the bridge.

(D) Program Audio Bridging

An arrangement to provide multiple channel outputs from a single Program Audio or Voiceband facility. This arrangement is provided and rated on a per port basis.

(E) DDS Bridging

Provides for a multi-junction unit (MJU) arrangement to bridge 2.4 kbps, 4.8 kbps, 9.6 kbps, 19.2 kbps, 56 or 64 kbps DDS facilities. Different speeds cannot be mixed on the same bridge. This function is provided on a per port basis.

<sup>[1]</sup> Effective February 1, 2020 Voiceband, Program Audio and Digital Data Services are grandfathered. Availability to current customers is limited to circuits in service at existing locations.

## FACILITIES FOR INTERSTATE ACCESS

5. Special Access Service (Cont'd)5.4.2 Conditioning Arrangements - Data

Data conditioning, when utilized in conjunction with effective four-wire Voiceband transmission facilities, improves the characteristics of these facilities. These improved characteristics are not represented to apply to the entire end to end facility of the customer, but only to that portion of the facility provided by the Telephone Company.

There are three types of data conditioning: Type C, Type C-Improved and Type DA. Type C and Type C-Improved conditioning control attenuation distortion and envelope delay distortion. Type DA controls the signal to C-notched noise ratio and intermodulation distortion. Type C and Type DA conditioning may be combined on the same circuit. Type C-Improved and Type DA conditioning may be combined on the same circuit.

Data conditioning is charged for on a per channel termination basis. The parameters listed for each type of data conditioning apply from two or more CDLs located within the Company serving area. Conditioning parameters apply to each end of a two-point circuit. For multipoint circuits, the conditioning parameters apply from any CDL to either the point of interface at another CDL or the first Telephone Company bridging point depending on the circuit configuration. These parameters are not applicable to High Capacity points of interface, because there is no voice frequency test access point. In these instances the data conditioning parameters apply to the last telephone company voice frequency test access point before the High Capacity point of interface.

(A) Type C

Type C conditioning of Voiceband facilities provides a facility with the following transmission parameters enhanced to meet the values specified for Type C conditioning in Section 7000 of the GTE Technical Interface Reference Manual in addition to the standard parameters for Voiceband circuits.

- (1) Attenuation distortion with reference to 1004 Hz.
- (2) Envelope delay distortion.

(B) Type C-Improved

Type C-Improved conditioning of Voiceband facilities provides a facility with the following transmission parameters enhanced to meet the values specified for Type C conditioning in Section 7000 of the GTE Technical Interface Reference Manual in addition to the standard parameters for Voiceband circuits.

- (1) Improved attenuation distortion with reference to 1004 Hz.
- (2) Improved envelope delay distortion.

The customer may choose to order Improved Attenuation Distortion or Improved Envelope Delay Distortion or both configurations. The rates specified for Type C-Improved conditioning, Section 5.7.2(B), will apply regardless of the configuration specified.



## FACILITIES FOR INTERSTATE ACCESS

5. Special Access Service (Cont'd)5.4.2 Conditioning Arrangements – Data (Cont'd)(C) Type DA

Type DA conditioning of Voiceband facilities provides a facility with the following transmission parameter enhanced to meet the values specified for Type DA conditioning in Section 7000 of the GTE Technical Interface Reference Manual in addition to the standard parameters for voiceband circuits.

- (1) Signal to C-notched noise ratio.
- (2) Nonlinear signal to second order distortion.
- (3) Nonlinear signal to third order distortion.

5.4.3 Conditioning - Program Audio(A) Stereo Conditioning

Provides the option of two radio program facilities which are identical in all transmission characteristics. Two Program Audio facilities are required to provide this Supplemental Feature. This feature is normally used only with Program Audio 50 to 15000 Hz facilities. Stereo Conditioning is charged on a per occurrence basis.

(B) Zero Loss

Conditioning of Program Audio facilities to provide zero loss at 1000 Hz test frequency. Zero Loss is charged on a per Special Access Line basis.

## FACILITIES FOR INTERSTATE ACCESS

5. Special Access Service (Cont'd)5.4.4 Signaling Arrangements

Signaling arrangements, when furnished with Voiceband transmission facilities, enable the facilities to accommodate standard telecommunications signaling protocols. Signaling arrangements provide for the conversion of one signaling method to another signaling method and/or extension of a signaling method at customer and Telephone Company interfaces and enables the transmission facilities to accommodate signaling transmission. Signaling arrangements are available with Voiceband transmission facilities to enable transmission of requested signaling formats. The third and fourth protocol characters of the Network Channel Interface (NCI) and Secondary Network Channel Interface (SEC NCI) codes as indicated on the customer's order, reflect signaling activity. Typical protocol characters contained in the NCI or SEC NCI codes that designate signaling arrangements are: AB, AC, DS, DX, DY, EA, EB, EC, EX, GO, GS, LA, LB, LC, LO, LR, LS, NO, RV and SF.

The customer identified NCI and SEC NCI codes will be considered the customer's request for signaling. The Telephone Company will endeavor to provide the specific signaling protocols requested by the customer. In those cases where facilities and equipment are not available to meet the customer's specific requests, the Telephone Company will provide the customer acceptable alternate protocols. Sections 3300, 6000 and 7000 of the GTE Technical Interface Reference Manual provide detailed technical descriptions of the signaling protocols normally available with each service offering. To properly provision SF signaling, when associated signaling code, is DS (PCM), additional information of SF requirements (loop signaling type DX/E&M or ringdown) must accompany the customer's order.

Signaling arrangement charges apply whenever interfaces at the customer premises or at the customer's Telephone Company serving wire center require a signaling arrangement other than those provided with the Terminating Options in 5.3.2 preceding. Signaling Arrangements will be charged on a per SAL basis. Specifically, a signaling charge applies if the signaling protocol characters in the NCI and the SEC NCI fields are different and include one of the following codes: RV, EX, SF, DX, DY, DS, AB.

## FACILITIES FOR INTERSTATE ACCESS

5. Special Access Service (Cont'd)5.4.4 Signaling Arrangements (Cont'd)

For the above conditions, one additional signaling charge applies for each additional leg of multipoint circuit. When a Multiplexing Arrangement is ordered that converts a single higher capacity or bandwidth circuit into several lower Voiceband circuits, the Voiceband Signaling Arrangements are provided as part of the Multiplexing Arrangement, and no additional Signaling Arrangement charges will apply.

A signaling charge applies in addition to any other applicable signaling charge when loop range extension equipment is required. The Telephone Company will obtain customer approval for signaling range extension equipment.

Listed below are the Signaling Arrangements offered under this service guide:

- (A) Loop Signaling Range Extension - An arrangement to extend the metallic resistance limitations of loop type signaling.
- (B) Conversion of Loop or E&M Signaling to SF - An arrangement to convert loop or E&M signaling to the single frequency signaling format.
- (C) E&M to DX Signaling Conversion - Conversion of E&M signaling to the DX signaling format.
- (D) E&M to Loop Signaling Conversion - Conversion of E&M signaling format to the loop type signaling.
- (E) Loop or E&M to PCM Signaling - Conversion of loop or E&M signaling to the digital (PCM) signaling format.
- (F) Automatic Ringdown Signaling (ARD) - A signaling arrangement on a two-point Special Access which converts loop seizure at one end of the facility into ringing signal at the opposite end.

5.4.5 Echo Control(A) Echo Cancellor

An arrangement provided at the customer's request to cancel reflected speech energy on a four-wire facility. This conditioning is generally required on circuits with long propagation delay. Echo canceller is charged on a per Special Access circuit basis.

## FACILITIES FOR INTERSTATE ACCESS

5. Special Access Service (Cont'd)5.4.6 Improved Return Loss

Improved Return Loss provides for increased echo return and ringing return parameters of an effective two-wire channel. This optional feature is available with certain Voiceband services at a two-wire point of termination when the transmission interface is four-wire at one CDL and two-wire at the other CDL. Placement of Company equipment may be required at the customer's premises with the two-wire point of termination.

Improved Return Loss rates and charges will apply on a per Special Channel Termination basis at the rates specified in 5.7.2(B) following. Technical parameters and the applicable Voiceband services are specified in Section 7000 of the GTE Technical Interface Reference Manual.

5.4.7 Voiceband Facility Switching Arrangement

An arrangement to provide switching between two Voiceband Special Access Services. This arrangement may require a Voiceband control circuit to control the switching arrangement at an additional charge.

5.4.8 Automatic Protection Switch

Consists of special switching equipment placed at both ends of a duplicate DS1 facility (i.e., DS1, High Capacity Circuit) for automatic switching to the duplicate (standby) facility in the event the active facility is inoperative.

Duplicate facilities may terminate at a serving wire center, a CDL or both. The option provided under this service guide only includes the APS(s) located at a serving wire center(s). When the duplicate facility terminates at a CDL, the customer will be responsible for providing the associated APS and ensuring it is compatible with the Company provided switch if appropriate.

The duplicate facilities are not a part of this supplemental feature.

## FACILITIES FOR INTERSTATE ACCESS

5. Special Access Service (Cont'd)5.4.9 Improved Termination Option

Improved Termination provides for a fixed 600 ohm impedance, an increased range of transmission levels, and simplex reversal (when applicable) on an effective four-wire channel. This optional feature is available with most Voiceband services with a four-wire point of termination. Telephone Company equipment is required at the customer's premises where this option is ordered.

The Improved Termination option will be ordered and rates and charges, as set forth in 5.7.2(B) following, will apply on a per Channel Termination basis. Technical parameters and the applicable Voiceband services are specified in Section 7000 of the GTE Technical Interface Reference Manual.

5.4.10 Improved Equal Level Echo Path Loss Option - ELEPL-2

This option provides improved echo control parameters for an effective two-wire channel at a four-wire point of termination. Placement of Company equipment may be required at the customer's premises with the two-wire point of termination.

The term "Equal Level Echo Path Loss" (ELEPL) represents the measure of Echo Path Loss (EPL) at a four-wire interface which is corrected by the difference between the send and receive Transmission Level Point (TLP), i.e.,  $ELEPL = EPL - TLP(\text{send}) + TLP(\text{receive})$ .

Improved ELEPL rates and charges will apply on a perChannel Termination basis at the rates set forth in 5.7.2(B) following. Technical parameters are specified in Section 7000 of the GTE Technical Interface Reference Manual.

5.4.11 Digital Data Service Secondary Channel

This feature is offered on an optional basis to customers of Digital Data Service. It is a separate, slower speed digital channel that operates in parallel with the companion Digital Data Service primary channel. The secondary channel allows for remote control and testing of the network and peripheral devices without taking the network out of service and without lowering the speed of the primary Digital Data Service channel. This feature is not available with 19.2 Kbps or 64 Kbps Digital Data Service.

Rates and charges as set forth in 5.7.5(C) will apply on a per Digital Data Service Channel Termination basis (each end of a two-point circuit and all ends of a multi-point circuit).

The provisioning of this option to existing Digital Data Service requires the discontinuance of the existing Digital Data Service and the establishment of new Digital Data Service for both ends of a two-point circuit and all ends of a multi-point circuit. The nonrecurring charges associated with the installation of Digital Data Service will apply.

## FACILITIES FOR INTERSTATE ACCESS

5. Special Access Service (Cont'd)5.5 Description of Multiplexing Arrangements

Multiplexing Arrangements provide the function to convert a single higher capacity or bandwidth circuit for bulk transport to several lower capacity or bandwidth circuits. Cascading multiplexing occurs when a high capacity analog or digital channel is de-multiplexed to provide channels with a lesser capacity and one of the lesser capacity channels is further de-multiplexed. For example, a DS1C may be de-multiplexed to two DS1 facilities and then the DS1 facilities may be further de-multiplexed to 24 Voiceband channels.

When cascading multiplexing is performed in the same or different Hub Wire Center, a charge for the additional multiplexing unit will also apply. When cascading multiplexing is performed at a different Hub Wire Center, Special Transport will also apply between the involved Hub Wire Centers.

Listed below are the multiplexing arrangements offered under this tariff.

(A) Group to Voice

An arrangement that multiplexes twelve voice grade circuits to a single wideband analog group band circuit, or multiplexes a single wideband analog group band circuit to twelve voice grade circuits.

(B) Supergroup to Group

An arrangement that multiplexes five wideband analog group band circuits to a single wideband analog supergroup band circuit, or multiplexes a single wideband analog supergroup band circuit to five wideband analog group band circuits.

(C) Mastergroup to Supergroup

An arrangement that multiplexes ten wideband analog supergroup band circuits to a single wideband analog mastergroup band circuit, or multiplexes a single wideband analog mastergroup band circuit to ten wideband analog supergroup band circuits.

(D) DS1 to Voice

An arrangement that multiplexes twenty-four voice grade circuits to a single DS1 digital circuit at a rate of 1.544 Mbps, or multiplexes a single DS1 digital circuit at a rate of 1.544 Mbps to twenty-four voice grade circuits. If this DS1 terminates in a DDS hub, a channel(s) of the DS1 can be used to provide DDS; however, DDS service stops at the DS1 interface. Multiple channels may be required to provide individual Program Audio Channels.

Up to 16 channels of this DS1 can be used for Direct Digital Service (DDS-like service) with the assurance that circuit performance parameters will be met. If more than 16 channels are used for DDS-like service, the performance parameters for the DS1 and all circuits riding the DS1 will not be guaranteed.

FT1 can be used in conjunction with DS1 to Voice Multiplexing in groupings of  $N \times 56$  Kbps or  $N \times 64$  Kbps where  $N = 2, 4$  or  $6$ , to a single DS1 digital circuit at a rate of 1.544 Mbps.

## FACILITIES FOR INTERSTATE ACCESS

5. Special Access Service (Cont'd)5.5 Description of Multiplexing Arrangements (Cont'd)(E) DS1C to Voice

An arrangement that multiplexes forty-eight voice grade circuits to a single DS1C digital circuit at a rate of 3.152 Mbps, or multiplexes a single DS1C digital circuit at a rate of 3.152 Mbps to forty-eight voice grade circuits.

(F) DS1C to DS1

An arrangement that multiplexes two DS1 digital circuits to a single DS1C digital circuit at a rate of 3.152 Mbps, or multiplexes a single DS1C digital circuit at a rate of 3.152 Mbps to two DS1 digital circuits.

(G) DS3 to DS1 and/or E1

An arrangement that multiplexes twenty-eight DS1 digital circuits to a single DS3 digital circuit at a rate of 44.736 Mbps, or multiplexes a single DS3 digital circuit at a rate of 44.736 Mbps to twenty-eight DS1 digital circuits.

In addition, where E1 service is available, this arrangement is capable of multiplexing:

- (1) twenty-one E1 digital circuits
- (2) four DS1 and eighteen E1 digital circuits
- (3) eight DS1 and fifteen E1 digital circuits
- (4) twelve DS1 and twelve E1 digital circuits
- (5) sixteen DS1 and nine E1 digital circuits
- (6) twenty DS1 and six E1 digital circuits
- (7) twenty-four DS1 and three E1 digital circuits

to a single DS3 digital circuit at a rate of 44.736 Mbps, or a single DS3 digital circuit at a rate of 44.736 Mbps to one of the combinations set forth in (1) through (7) above.

(H) DS3C to DS1

An arrangement that multiplexes fifty-six DS1 digital circuits to a single DS3C digital circuit at a rate of 89.472 Mbps, or multiplexes a single DS3C digital circuit at a rate of 89.472 Mbps to fifty-six DS1 digital circuits.

(I) Group to DS1

An arrangement that multiplexes two wideband analog groupband circuits to a single DS1 digital circuit at a rate of 1.544 Mbps, or multiplexes a single DS1 digital circuit at a rate of 1.544 Mbps to two wideband analog groupband circuits.

## FACILITIES FOR INTERSTATE ACCESS

5. Special Access Service (Cont'd)5.5 Description of Multiplexing Arrangements (Cont'd)(J) Digital Data Carrier Multiplexer

An arrangement that multiplexes a single DS1 1.544 Mbps digital circuit to twenty-three DSO digital ports for connection to either a subrate data multiplexer as described in 5.5(K) following or 56 Kbps digital circuits.

(K) Digital Data Subrate Multiplexer

Used with cascading multiplexing, the Digital Data Subrate Multiplexer is an arrangement that multiplexes the following quantities of subrate digital data circuits into a single DSO digital port: 1) twenty 2.4 Kbps, 2) ten 4.8 Kbps or 3) five 9.6 Kbps. In turn, the DSO digital port is then multiplexed to a single DS1 digital circuit using the Digital Data Carrier Multiplexer described in 5.5(J) preceding.



## FACILITIES FOR INTERSTATE ACCESS

5. Special Access Service (Cont'd)

## 5.6 Rate Regulations

This section contains specific regulations governing the rates and charges that apply for Special Access Service.

## 5.6.1 Types of Rates and Charges

These are the types of rates and charges. These are monthly rates and nonrecurring charges. The rates and charges are described as follows:

(A) Monthly Rates

Monthly rates are recurring charges that apply each month or fraction thereof that a Special Access Service is provided. For billing purposes, each month is considered to have 30 days.

(B) Daily Rates

Daily rates are recurring charges that apply to each 24 hour period or fraction thereof that a part-time Program Audio Special Access Service is provided. When part-time Program Audio service is provided for ten or more consecutive days it will be treated as a full-time service and monthly rates will apply. In no event will the charges for continuous part-time Program Audio service exceed the amount that would be charged in the same billing time period for full-time service.

(C) Reserved for Future Use(D) Reserved for Future Use

## FACILITIES FOR INTERSTATE ACCESS

5. Special Access (Cont'd)5.6 Rate Regulations (Cont'd)5.6.1 Types of Rates and Charges (Cont'd)(E) Nonrecurring Charges

Nonrecurring charges are one-time charges that apply for specific work activity, (i.e., installation of service or change to an existing service). The types of nonrecurring charges that apply for Special Access Service are those listed below.

(1) Design Change Charge

The customer may request a design change to the service ordered. A design change is any change to a pending ASR for Special Access Service which requires engineering review. Design changes include such things as the addition or deletion of supplemental features or changes in the terminating options. Changes of this nature will require the issuance of a new ASR and the cancellation of the original ASR. The cancellation charges apply as set forth in 3.2.6 preceding.

The Company will review the requested change, notify the customer whether the change can be accommodated and specify if a new service date is required. If the customer authorizes the Company to proceed with the design change, a Design Change Charge will apply.

The Design Change Charge, as set forth in 5.7.1 following, will apply on a per ASR per occurrence basis, for each ASR requiring a design change.

If a change of service date is required, the Service Date Change Charge as set forth in Section 3 preceding will also apply.

## FACILITIES FOR INTERSTATE ACCESS

5. Special Access (Cont'd)5.6 Rate Regulations (Cont'd)5.6.1 Types of Rates and Charges (Cont'd)(E) Nonrecurring Charges (Cont'd)(2) Installation of Supplemental Features and Multiplexing Arrangements

Nonrecurring charges apply for the installation of some supplemental features and multiplexing arrangements available with Special Access service. The charge applies whether the feature or multiplexing arrangement is installed coincident with the initial installation of service or at any time subsequent to the installation of service.

For additions of supplemental features without an NRC, a charge equal to a Channel Termination NRC will apply. Only one such charge per service, per order will apply.

(3) Installation of FT1, DS3, E1 and DS1 Channel Terminations(a) Fractional T1 Standard Arrangements

Customers subscribing to Fractional T1 service, at rates set forth in 5.7.8(A), will be assessed a nonrecurring charge. The NRC for Fractional T1 service will be assessed per Channel Termination.

(b) Fractional T1 Optional Payment Plan (OPP) Arrangements

Customers subscribing to the Fractional T1 OPP arrangements, at rates set forth in 5.7.8(B), will not be assessed a nonrecurring charge.

The Regulations in Section 5.6.1(E) will apply to FT1 OPP customers when required for changes and other service rearrangements.

## FACILITIES FOR INTERSTATE ACCESS

5. Special Access (Cont'd)5.6 Rate Regulations (Cont'd)5.6.1 Types of Rates and Charges (Cont'd)(E) Nonrecurring Charges (Cont'd)(3) Installation of FT1, DS3, E1 and DS1 Channel Terminations(c) DS3 Arrangements

There are two levels of charges for the installation of 3 System DS3 and Unlimited System DS3 Channel Terminations as set forth in 5.7.9 and 5.7.10. The "First System" charge is assessed for the first DS3 Channel Termination ordered by a customer. When the same customer requests additional DS3 Channel Terminations, to be installed between the same locations, the "Additional System" charge will apply for each Channel Termination ordered (maximum of two Additional System Channel Terminations in a 3 System DS3 and no maximum in an Unlimited System DS3).

For Individual DS3s, the charge for installation will apply at the same rate per DS3 Channel Termination, and for Group System DS3s\*, the charge applies per Group System Channel Termination.

(d) E1 Arrangements

Customers subscribing to E1 service will be assessed a nonrecurring charge and monthly rates. Suitable fiber optic facilities must be available at the CDL with no physical change in the existing configuration at the CDL. If this condition is not met, the customer will be advised that the ASR will not be processed. The customer may then cancel the ASR without charge, or may request the Company to provide such facilities in accordance with the Special Construction provisions in Brightspeed Local Operating Companies Tariff F.C.C. No. 5.

(e) DS1 Standard Arrangements

Customers subscribing to DS1 Standard Arrangements, at rates set forth in 5.7.7(A), will be assessed a nonrecurring charge. The NRC for DS1 Standard Arrangements will be assessed per Channel Termination.

The regulations in Section 5.6.1(E) will apply to existing DS1 Standard Arrangements customers when required for changes and other service arrangements.

## FACILITIES FOR INTERSTATE ACCESS

5. Special Access (Cont'd)5.6 Rate Regulations (Cont'd)5.6.1 Types of Rates and Charges (Cont'd)(E) Nonrecurring Charges (Cont'd)(4) Reserved for Future Use(5) Installation of Voice Grade, Program Audio and Digital Data Service Special Access Lines

The nonrecurring charge associated with the installation of voice grade Channel Terminations is specified in 5.7.2(A). The nonrecurring charge associated with the installation of program audio Channel Terminations is specified in 5.7.3(A) through (D). This charge will not apply to part-time Program Audio Channel Terminations which are left in place and reused.

The nonrecurring charge associated with the installation of DDS Channel Termination facilities and the provisioning of the customer specified transmission speed of 2.4, 4.8, 9.6, 19.2, 56 or 64 Kbps is specified in Section 5.7.5(A).

(6) Service Rearrangements

Service rearrangements are changes to existing (installed) services which may be administrative only in nature or involve an actual physical change to the service. Changes to pending orders are in 3.2.2.

Changes in the type of service will be treated as a discontinuance of the service and an installation of a new service.

Changes in the physical location of the point of termination are treated as moves which are described and charged for as in 5.6.4.

Administrative changes will be made without charge(s) to the customer.

## FACILITIES FOR INTERSTATE ACCESS

5. Special Access (Cont'd)5.6 Rate Regulations (Cont'd)5.6.1 Types of Rates and Charges (Cont'd)(6) Service Rearrangements (Cont'd)

Administrative changes are as follows:

- Change in name or ownership or transfer of responsibility from one customer to another, provided there is no interruption of use or relocation of Special Access service.
- Change of customer or customer's end user premises address when the change of address is not a result of a physical relocation of equipment,
- Change in billing data (name, address, or contact name or telephone number),
- Change of customer circuit identification,
- Change of billing account number,
- Change of customer test line number,
- Change of customer or customer's end user contact name or telephone number,
- Change of agency authorization, and
- Change in jurisdiction involving no physical changes to the service.

## FACILITIES FOR INTERSTATE ACCESS

5. Special Access (Cont'd)5.6 Rate Regulations (Cont'd)5.6.1 Types of Rates and Charges (Cont'd)(E) Nonrecurring Charges (Cont'd)(6) Service Rearrangements (Cont'd)

All other service rearrangements will be charged for as follows:

- If the change involves the addition of another termination to an existing two-point or multipoint service, installation charges for each location added will apply.
- If the change involves the addition of supplemental feature or multiplexing arrangement, the installation charge associated with the supplemental feature or multiplexing arrangement will apply. When the supplemental feature or arrangement has no associated nonrecurring charge (or rated at \$.00), one Channel Termination nonrecurring charge for the type of service involved (i.e., Voice Grade Channel Termination, DDS Channel Termination, etc.) will be applied to the order.
- If the change involves only changing the type of network interface, with no change in facility, the installation charge associated with each service receiving a network interface change will apply.
- If the change involves changing a two-wire service to a four-wire service or vice versa, the installation charge for each location changed will apply.
- If the change involves only rollovers or grooming, then no charges will apply. A rollover is the retermination of a segment of a lower capacity special access service onto a higher capacity special access service. The rollover must occur in the wire center where the higher capacity service is multiplexed with no other changes to the lower capacity service being reterminated (i.e., the segment must not require rerouting to connect to the multiplexer of the higher capacity service).

Grooming is the retermination of a lower capacity special access service from one channel in a higher capacity special access service to another channel in the same higher capacity service or to another channel in another higher capacity special access service (i.e., change in connecting facility assignment) in the same wire center, with no other changes to the lower capacity service.

FACILITIES FOR INTERSTATE ACCESS

5 SPECIAL ACCESS (Cont'd)

5.6 Rate Regulations (Cont'd)

5.6.1 Types of Rates and Charges (Cont'd)

(E) Nonrecurring Charges (Cont'd)

(6) Service Rearrangements (Cont'd)

ROLLOVER – EXAMPLE 1  
Current Configuration

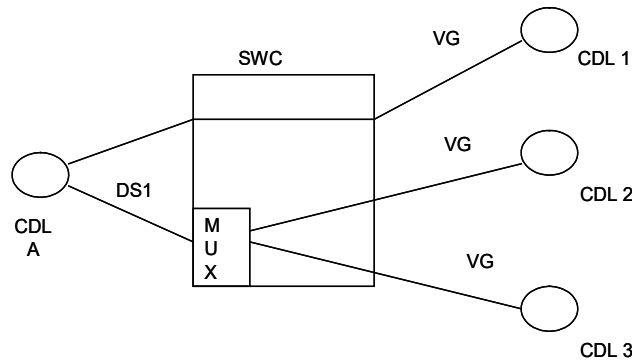

The customer requests that the voiceband circuit (VG) between CDL A and CDL 1 be "rolled over" to the DS1 serving CDL A. No NRCs apply for this request.

ROLLOVER – EXAMPLE 1  
New Configuration

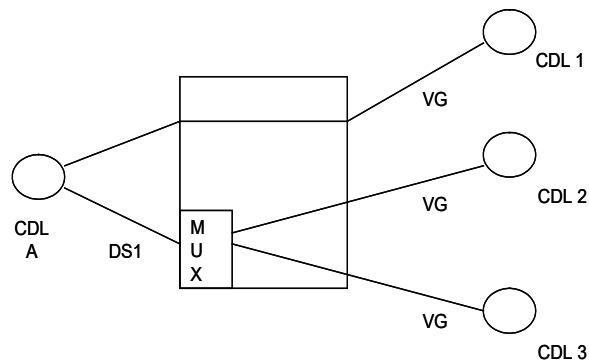



FACILITIES FOR INTERSTATE ACCESS

5 SPECIAL ACCESS (Cont'd)

5.6 Rate Regulations (Cont'd)

5.6.1 Types of Rates and Charges (Cont'd)

(E) Nonrecurring Charges (Cont'd)

(6) Service Rearrangements (Cont'd)

ROLLOVER – EXAMPLE 2  
Current Configuration

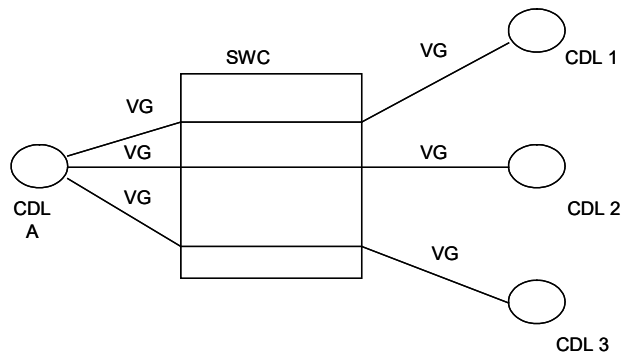

The customer requests the installation of a DS1 between the serving wire center (SWC) and CDL A and a DS1/voice multiplexer in the SWC. The customer also requests that the voiceband circuits serving CDLs 1, 2 and 3 be "rolled over" to the new DS1. All NRCs apply for the installation of the DS1 and multiplexer. No NRCs apply for the voiceband rollovers to the new high capacity circuit.

ROLLOVER – EXAMPLE 2  
New Configuration

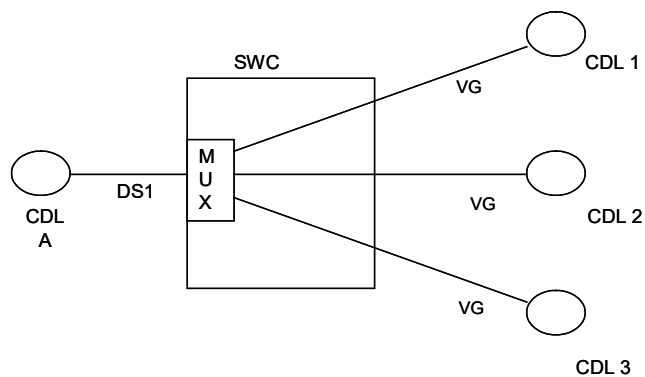

FACILITIES FOR INTERSTATE ACCESS

5 SPECIAL ACCESS (Cont'd)

5.6 Rate Regulations (Cont'd)

5.6.1 Types of Rates and Charges (Cont'd)

(E) Nonrecurring Charges (Cont'd)

(6) Service Rearrangements (Cont'd)

GROOMING – EXAMPLE 1  
Current Configuration

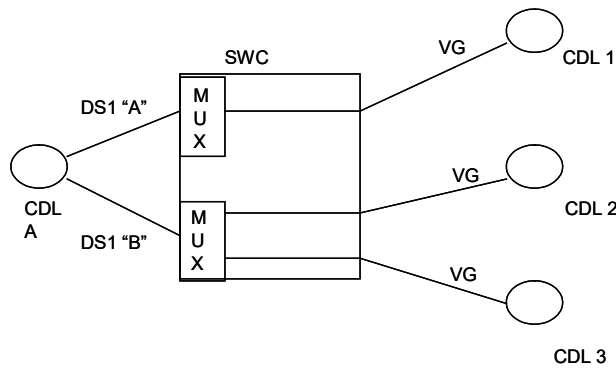

The customer requests that the voiceband (VG) circuit serving CDL 1 be moved from the DS1 "A" circuit to the DS1 "B" circuit. No NRCs apply for this request.

GROOMING – EXAMPLE 1  
New Configuration

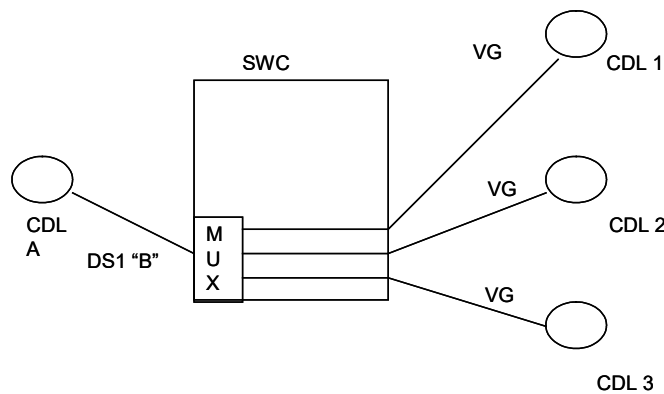

FACILITIES FOR INTERSTATE ACCESS

5 SPECIAL ACCESS (Cont'd)

5.6 Rate Regulations (Cont'd)

5.6.1 Types of Rates and Charges (Cont'd)

(E) Nonrecurring Charges (Cont'd)

(6) Service Rearrangements (Cont'd)

GROOMING – EXAMPLE 2  
Current Configuration

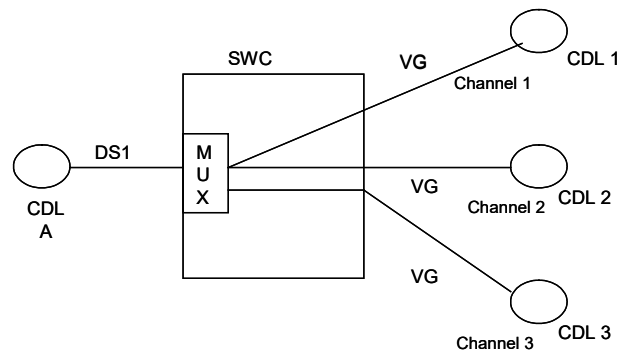

The customer requests that the voiceband circuit serving CDL 3 be moved from channel 20 in the DS1 serving CDL A to Channel 3 in the same DS1. No NRCs apply for this request.

GROOMING – EXAMPLE 2  
New Configuration

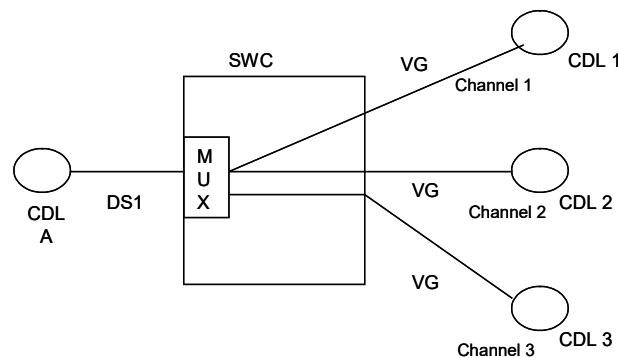

- If the change involves reterminations other than Rollovers and/or Grooming, all NRCs associated with the installation of the lower capacity service will apply.
- In cases where multiple service rearrangements or an additional termination or a move and a service rearrangement are requested on a single ASR, the total charge will never exceed the full nonrecurring charge for the base service.

## FACILITIES FOR INTERSTATE ACCESS

5. Special Access (Cont'd)5.6 Rate Regulations (Cont'd)5.6.2 Minimum Periods

Special Access is provided for a specified minimum period. Additional Minimum periods on other services, minimum period charges and associated termination liability charges are described in Section 3 preceding.

5.6.3 Mileage Measurement

The mileage to be used to determine the monthly rate for the Special Transport is calculated on the airline distance between the serving wire centers involved (i.e., CDL serving wire center or Hub Wire Center or WATS Serving Office). Where the calculated miles include a fraction, the value is always rounded up to the next full mile. Where the calculated value is zero, no Special Transport mileage is charged.

When there is a Hub Wire Center involved, the Special Transport mileage will be measured from the Hub Wire Center to the serving wire centers of each of the CDLs connected to the hubbed facilities. Mileage is computed for each section and rates are applied accordingly. However, when a Special Access facility is routed through a Hub Wire Center for purposes other than customer specified rates will be applied only to the distance calculated between the wire centers serving the CDLs.

The rates for the mileage are applied per airline mile. The serving wire center V&H coordinates and the method of calculation are specified in the National Exchange Carrier Association, Tariff F.C.C. No. 4.

5.6.4 Moves

A move involves a change in the physical location of the point of termination of Special Access. A move normally involves an interruption of Special Access for the period required to complete the move. No credit allowance will be granted for that period. Special Construction as set forth in Brightspeed Local Operating Companies Tariff F.C.C. No. 5 may also be applicable at the different CDL.

A customer may request that Special Access not be interrupted during a move. To comply with that request, it may be necessary to install a duplicate Special Access, and subsequently discontinue the existing Special Access. Charges, monthly and nonrecurring, will apply for the duplicate Special Access. A new minimum period will be established for the duplicate portion of the Special Access, depending on which end of the Special Access is moved. The customer will remain responsible for all minimum period charges associated with the corresponding portion of the disconnected Special Access.

The charge for the move depends on whether the move is within the same CDL or to a different CDL.

## FACILITIES FOR INTERSTATE ACCESS

5. SPECIAL ACCESS (Cont'd)5.6 Rate Regulations (Cont'd)5.6.4 Moves (Cont'd)(A) Same CDL

When the move of a termination of FIA, as defined in Section 2.1.5, for special access is to a new point within the same CDL (same address and/or same building), the charge for the move will be the installation charge for the portion of the service being reterminated. There will be no change in the minimum period requirements. For services subject to payment plan regulations, the same payment period will remain in force.

(B) Different CDL

(1) When the move is to a different CDL (different address and different building), except as specified below, it will be treated as a disconnect and an installation of service. The appropriate service installation charge for the service termination(s) affected will apply. A new minimum period will be established for the installed Special Access Service. The customer will remain responsible for all minimum period charges associated with the disconnected Special Access Service. For services subject to payment plan regulations, a new payment plan will be established and full assessment of the remaining liabilities will be applicable.

(2) When the move is to a different CDL but served by the same serving wire center, the following conditions apply:

- A change ASR will be required.
- The appropriate service installation charge for the service termination(s) affected will apply.
- For Special Access services subject to payment plan regulations, if the customer of record remains the same with no lapse in service, the appropriate NRCs for changes will apply. Otherwise, the move will be treated as a disconnect and an installation of service and all appropriate NRCs and full assessment of the remaining liabilities will be applicable.

## FACILITIES FOR INTERSTATE ACCESS

5. SPECIAL ACCESS (Cont'd)5.6 Rate Regulations (Cont'd)5.6.5 Rates and Charges on an Individual Case Basis

(A) The monthly rates and nonrecurring charges for the following service offerings will be developed on an Individual Case Basis:

- High Capacity Digital DS1C (3.152 Mbps) Special Access Lines
- High Capacity Digital DS1C (3.152 Mbps) Special Transport
- High Capacity Digital DS3C (89.472 Mbps) Facilities

(B) The monthly rates and nonrecurring charges for the following Multiplexing Arrangements will be developed on an Individual Case Basis:

Group to Voice  
Supergroup to Group  
Mastergroup to Supergroup  
DS1C to Voice  
DS1C to DS1  
DS3C to DS1  
Group to DS1

## FACILITIES FOR INTERSTATE ACCESS

5. SPECIAL ACCESS (Cont'd)5.6 Rate Regulations (Cont'd)5.6.6 Hub Wire Centers

A Hub Wire Center is a Company designated serving wire center at which bridging or multiplexing arrangements are provided. Bridging is used to connect three or more CDLs in a multipoint arrangement. The multiplexing arrangements channelize analog or digital facilities to individual services requiring a lower capacity or bandwidth.

Although Hub Wire Centers are defined as serving wire centers at which bridging or multiplexing arrangements are performed, they are not limited to providing these functions and may provide any other types of Special Access services offered in this service guide. For example, the Company will designate certain Hub Wire Centers for Program Audio service offerings.

The Telephone Company will designate the Hub Wire Center locations. Different locations may be designated as Hub Wire Centers for different functions, such as bridging or multiplexing arrangements, for different facility capacities (e.g., multiplexing from digital to digital may occur at one wire center while multiplexing from digital to analog may occur at a different wire center). The location of Hub Wire Centers and the types of hubbing functions offered at that location are identified in the NECA Tariff FCC No. 4.

Some of the types of multiplexing provided include the following:

- from higher to lower bit rate,
- from higher to lower bandwidth,
- from digital to voice grade service.

The transmission performance for the end to end Special Access provided from CDLs will be that of the lower capacity or bit rate. For example, when a DS1 Special Access is multiplexed to voice frequency circuits, the transmission performance will be Voiceband, not High Capacity.

The Company will commence billing the monthly rate for the High Capacity facility to the Hub Wire Center as of the service date, even though individual services utilizing those facilities may not be installed until a later date. If the customer has designated the type of multiplexing to be provided with the High Capacity facility, the nonrecurring charge for the Multiplexing Arrangement will be billed to the same customer at that same time, and the billing for the monthly rate will begin.

Individual Special Access rates (by Special Access type) will apply for the Channel Termination and additional Special Transport facilities (if required) for each channelized Special Access. These will be billed to the customer specified on the ASR as each individual Special Access is installed. Shared use of a digital high capacity facility is provided for in 5.6.7.

A customer may order full-time and/or part-time Program Audio Services between two CDLs, or between a CDL and a Hub Wire Center, and will be billed accordingly at the rates set forth in Sections 5.7.3(A), 5.7.3(B), 5.7.3(C) and 5.7.3(D) following.

At the request of the customer, the full-time and/or part-time services provided to a Hub Wire Center may be connected together in the following configurations: full-time to full-time, full-time to part-time, or part-time to part-time.

The rates that apply for Program Audio Services between each CDL and the Hub Wire Center are Special Transport, if applicable, and Special Access Line. In addition, rates for Supplemental Features may be applicable.

## FACILITIES FOR INTERSTATE ACCESS

5. SPECIAL ACCESS (Cont'd)5.6 Rate Regulations (Cont'd)5.6.7 Shared Use Analog and Digital High Capacity Services

Monthly charges for a DS1 or DS3 high capacity shared used facility will be apportioned between Switched and Special Access based on the relative proportion of channels used for switched and special access in the following manner.

If the facility is ordered as Special Access, rating as Special Access will continue until such time as a portion of the available capacity is used to provide Switched Access service. As individual channels are activated for Switched Access, monthly charges will be apportioned between Switched and Special Access based on the number of channels used for Switched Access and the number of remaining channels on the Special Access facility according to the following formula:

- The total shared use charge is equal to the Monthly Switched Access Charge times the number of channels used for Switched Access divided by 24 for DS1 or 672 for DS3 plus the monthly Special Access Charge times the number of channels remaining for Special Access divided by 24 for DS1 or 672 for DS3.

If the facility is ordered as Switched Access, rating as Switched Access will continue until such time as a portion of the available capacity is used to provide Special Access service. As individual channels are activated for Special Access, monthly charges will be apportioned between Switched and Special Access based on the number of channels used for Special Access and the number of remaining channels on the Switched Access Facility according to the following formula:

- The total shared use charge is equal to the Monthly Special Access Charge times the number of channels used for Special Access divided by 24 for DS1 or 672 for DS3 plus the monthly Switched Access Charge times the number of channels remaining for Switched Access divided by 24 for DS1 or 672 for DS3.

The monthly Switched and Special Access rate used will be the appropriate rate (Special Access SAL, Transport, Multiplexer and Switched Access Entrance Facility, Direct-Trunked Transport and Multiplexer for the underlying shared use facility, i.e., if the underlying facility is a Special Access DS3 service, the corresponding Switched Access DS3 Transport will be used to determine the Switched Access monthly charges.

Shared use of Special Access Fractional T1 (FT1) is not available.

5.6.8 Reserved for Future Use



## FACILITIES FOR INTERSTATE ACCESS

5. SPECIAL ACCESS (Cont'd)5.6 Rate Regulations (Cont'd)5.6.9 Special Access Surcharge

Pending the development of techniques to accurately measure usage of local facilities which are interconnected by users by means of interstate or foreign telecommunications, a surcharge of \$25.00 per service per month will be assessed to a two point Special Access Service, and to each additional Special Access Line when the service is configured as multipoint. The Special Access Surcharge will also be assessed upon High Capacity Digital and FT1 Services on a voiceband equivalent basis. The voiceband equivalency for these type services is as follows:

- High Capacity DS1 equates to 24 Voiceband Facilities
- High Capacity DS1C equates to 48 Voiceband Facilities
- High Capacity DS3 equates to 672 Voiceband Facilities
- High Capacity DS3C equates to 1344 Voiceband Facilities
- Each 56 Kbps or 64 Kbps channel in a FT1 Service equates to one Voiceband Facility.
- High Capacity E1 equates to 30 Voiceband Facilities

The Special Access Service will be exempted from the monthly surcharge if the customer provides the Company written certification that the termination is as follows:

- A termination that the customer certifies to the Company is not connected to a PBX or other device capable of interconnecting the Special Access Service to the local network. If the PBX or other device has been configured either through software programming or physical restrictions not to access the local network, then the customer may file the surcharge exemption for the Special Access Service terminating on this equipment.

In order for the Company to determine the application of the surcharge with respect to specific services, the customer must report the intended use of all services when placing ASRs for Special Access Service. If the intended use is not reported, the surcharge will apply. In addition, when ordering High Capacity Analog or Digital services, the customer must report the use for each voice equivalent circuit of the high capacity service.

If, at any time after the installation of a service which is subject to the surcharge, the customer reports that the service should have been exempted, the Company will credit the customer for the surcharge. Credit will not be given beyond the receipt date of the certification for exemption.

5.6.10 Message Station Equipment Recovery Charge

Message Station Equipment Recovery Charge is a charge to recover that portion of message station equipment which is assigned to Special Access Service. Since there is zero cost assigned to Message Station Equipment Recovery in Special Access the charge is \$.00.

## FACILITIES FOR INTERSTATE ACCESS

5. SPECIAL ACCESS (Cont'd)5.6 Rate Regulations (Cont'd)5.6.11 DS3 High Capacity Service

Effective May 16, 2019 the following DS3 High Capacity 1, 3 5 and 7 Year Rate Plans will be grandfathered until the expiration date of the current term. Term renewals will not be offered on these plans going forward as of this effective date. Upon expiration of the current term, rates will revert to month-to-month.

(A) DS3 Rate Structure

A DS3 (44.736Mbps) High Capacity Channel Termination, whether an Individual, 3-System or Unlimited System, may be purchased with or without electronics. When a Channel Termination is ordered with electronics the Company will place electronics at both the CDL and the serving wire center. When a Channel Termination is ordered without electronics the Company will only place electronics at the serving wire center and not at the CDL. Effective May 18, 2002 when a DS3 Channel Termination is ordered without electronics the interface must be optical unless an Additional Channel Termination is added to an existing System with an electrical interface. When ordered with electronics the interface may be electrical or optical.

DS3 Channel Terminations are non-distance sensitive and are provided on a protected basis.

Individual System

An Individual System is a single DS3 between a CDL and the serving wire center. The appropriate NRC is applied per Channel Termination.

Transport rate elements are applied per Channel Termination when transport between offices is required. In instances when a Channel Termination is ordered to a second CDL in conjunction with an Individual System Channel Termination and Transport between offices is required Transport rate elements are applied per circuit.

## FACILITIES FOR INTERSTATE ACCESS

5. SPECIAL ACCESS (Cont'd)5.6 Rate Regulations (Cont'd)5.6.11 DS3 High Capacity Service [1] (Cont'd)(A) DS3 Rate Structure (Cont'd)3-System

The 3-System allows the same customer, between the same CDL and the serving wire center, to order additional DS3 Channel Terminations, up to a maximum of two. Additional Channel Terminations may only be added with the same interface, electrical or optical, and with Company electronics or without Company electronics as the First System. The appropriate NRC is applied per Channel Termination.

Transport rate elements are applied per Channel Termination when transport between offices is required. In instances when a Channel Termination is ordered to a second CDL in conjunction with a 3-System Channel Termination and Transport between offices is required, Transport rate elements are applied per circuit.

Unlimited System

The Unlimited System allows the same customer, between the same CDL and the serving wire center, to order additional DS3 Channel Terminations, with no maximum. Additional Channel Terminations may only be added with the same interface, electrical or optical, and with Company electronics or without Company electronics as the First System. The appropriate NRC is applied per Channel Termination.

Transport rate elements are applied per Channel Termination when transport between offices is required. In instances when a Channel Termination is ordered to a second CDL in conjunction with an Unlimited System Channel Termination and Transport between offices is required, Transport rate elements are applied per circuit.

[1] Effective May 16, 2019 the DS3 High Capacity 1, 3, 5 and 7 Year Rate Plans will be grandfathered until the expiration date of the current term. Term renewals will not be offered on these plans going forward as of this effective date. Upon expiration of the current term, rates will revert to month-to-month.

## FACILITIES FOR INTERSTATE ACCESS

5. SPECIAL ACCESS (Cont'd)5.6 Rate Regulations (Cont'd)5.6.11 DS3 High Capacity Service [1] (Cont'd)(A) DS3 Rate Structure (Cont'd)

A DS3 Channel Termination provides a spare transmission path (transmit and receive) connected to an automatic protection switch. In the event of failure in the primary service, traffic will be automatically transferred to the spare transmission facilities. The spare transmission path will normally be provided on the same route as the primary path. When a customer orders a DS3 Channel Termination, the customer may request that the spare transmission path be provided via an alternate route provisioned as the Company may elect. If common points for the primary and alternate route become necessary, these points will be identified by the Company and provided to the ordering customer. Should the routing arrangement require special routing requirements specified by the customer, other rates and regulations as set forth in Section 9 of this service guide or special construction under Brightspeed Local Operating Companies Tariff F.C.C. No. 5 may be applicable.

A customer may order the same or different type of DS3 Channel Terminations for each CDL(s) at which DS3 service is terminated.

When a customer requests the disconnect of a DS3 service in the 3 System DS3 or Unlimited System DS3, an Additional System DS3 Channel Termination must be disconnected first. When only the First DS3 service exists, that service will be disconnected.

Any costs associated with Special Construction as set forth in Section 10 will apply.

DS3 Special Transport contains two rate elements, Special Transport Termination and Special Transport Facility. Special Transport Termination rates apply for the termination of each end of the interoffice facility. Special Transport Facility rates apply for each airline mile of the interoffice facility.

[1] Effective May 16, 2019 the DS3 High Capacity 1, 3, 5 and 7 Year Rate Plans will be grandfathered until the expiration date of the current term. Term renewals will not be offered on these plans going forward as of this effective date. Upon expiration of the current term, rates will revert to month-to-month.

## FACILITIES FOR INTERSTATE ACCESS

5. SPECIAL ACCESS (Cont'd)5.6 Rate Regulations (Cont'd)5.6.11 DS3 High Capacity Service [1] (Cont'd)(B) Minimum Service Periods

Effective May 6, 2019 the minimum service period for Individual DS3s and System DS3s is one month. Prior to May 16, 2019 Individual DS3s and System DS3s are offered under four minimum service periods, each with different rate levels. The minimum service periods are 1, 3, 5 and 7 years. The customer must specify the minimum service period at the time the service is ordered. First and Additional DS3 SALs (3 System DS3s and Unlimited System DS3s) can have a different minimum service period. However, each DS3 SAL of a two-point DS3 service must have the same minimum service period.

The customer may select a longer minimum service period at any time, without penalty or application of nonrecurring charges, to obtain the lower monthly recurring rates associated with a longer minimum service period. When the customer selects this option, no credit toward the new service period will be given for the amount of time they were under the shorter minimum service period. The new recurring charges will apply subsequent to the effective date of the new minimum service period.

(C) Expiration of Service Period

Effective May 16, 2019 term renewals will not be offered on the DS3 HighCapacity 1, 3, 5 and 7 Year Rate Plans. Upon expiration of the current term, rates will revert to month-to-month. Prior to May 16, 2019, at the expiration of a service commitment period, the customer may select a new DS3 commitment period. If the customer does not select a new minimum service period within 60 days from the expiration date, billing will remain at the current service period and a new DS3 minimum service period will begin based on the previously effective service period. All terms and conditions, including Subsequent Termination Liabilities, will apply to the new DS3 period.

Customers with expired service periods for the Individual System, Three System and Unlimited System DS3s, prior to the effective date of this tariff offering will have up to 180 days to select a new commitment service period. If the customer does not select a new service period within 180 days of the effective date of this tariff, billing will remain at the current service period and a new DS3 minimum service period will begin based on the last service period. The beginning date of the new service period will be the date immediately following the expiration date of the expired service period.

[1] Effective May 16, 2019 the DS3 High Capacity 1, 3, 5 and 7 Year Rate Plans will be grandfathered until the expiration date of the current term. Term renewals will not be offered on these plans going forward as of this effective date. Upon expiration of the current term, rates will revert to month-to-month.

## FACILITIES FOR INTERSTATE ACCESS

5. SPECIAL ACCESS (Cont'd)5.6 Rate Regulations (Cont'd)5.6.11 DS3 High Capacity Service [1] (Cont'd)(D) Discontinuance Without Liability - DS3 Minimum Service Period

Should the recurring charges for a customer's DS3 service increase, in aggregate, by more than 10% from the original recurring charges during the minimum service period, the customer may, at their option, terminate the DS3 service without penalty or liability.

[1] Effective May 16, 2019 the DS3 High Capacity 1, 3, 5 and 7 Year Rate Plans will be grandfathered until the expiration date of the current term. Term renewals will not be offered on these plans going forward as of this effective date. Upon expiration of the current term, rates will revert to month-to-month.

FACILITIES FOR INTERSTATE ACCESS

5. SPECIAL ACCESS (Cont'd)

5.6 Rate Regulations (Cont'd)

5.6.11 DS3 High Capacity Service [1] (Cont'd)

(E) Discontinuance With Liability - DS3 Minimum Service Period

When a DS3 service is discontinued prior to the end of the minimum service period, the customer will be liable for a percentage of the total monthly charges for the remaining portion of the applicable minimum service period. This charge will be based on the rates in effect at the time of disconnect. There are two liability periods for DS3 service, "first liability period" and "subsequent liability period". The "first liability period" is the period beginning from the establishment of the DS3 and is based on the customer's initial commitment term for the DS3. The "subsequent liability period" is the period after the customer's initial commitment term has expired and the customer wants to renew the DS3 service with the existing term period or select a new DS3 term period. The customer's total liability for the "first liability period" or "subsequent liability period" is dependent upon the number of months remaining within the year that the service is discontinued times the liability rate for that year plus the total monthly charges for each annual period remaining in the "first liability period" or "subsequent liability period" times the applicable liability rate. The liability rates for each year of the minimum service period are as follows:

<u>Year In Which Service Is Discontinued</u>	<u>1st Liability Period Rate</u>	<u>Subsequent Liability Period Rate</u>
1	45%	20%
2	30%	20%
3	25%	20%
4	20%	20%
5	20%	20%
6	20%	20%
7	20%	20%

For example, if a customer with a first liability period of seven years discontinues the DS3 service after six months within the 4th year, the customer will be liable for 20% of the total monthly charges for six months, 20% of the total monthly charges for the 6th year and 20% of the total monthly charges for the 7th year.

For example, if DS3 service is disconnected during the subsequent seven year liability period, the customer will be liable for 20% of the total monthly charges for the remaining months for each annual period remaining in the seven year minimum service period.

Customers with a minimum service period arrangement of three years or greater established on or prior to September 17, 1992, who discontinue service are eligible for limitation of the termination liability as set forth below.

Customer liability will be calculated as previously stated but will be limited to:

The dollar difference between 1) the amount the customer has already paid and, 2) any additional charges that the customer would have paid for service if the customer had taken a shorter term offering corresponding to the term actually used.

For example, if a customer with a seven year minimum service period discontinues service six months after the end of the third year, the customer liability will not exceed:

$$(Three\ year\ monthly\ rate - Seven\ year\ monthly\ rate) \times 42\ months$$

[1] Effective May 16, 2019 the DS3 High Capacity 1, 3, 5 and 7 Year Rate Plans will be grandfathered until the expiration date of the current term. Term renewals will not be offered on these plans going forward as of this effective date. Upon expiration of the current term, rates will revert to month-to-month.

## FACILITIES FOR INTERSTATE ACCESS

5. SPECIAL ACCESS (Cont'd)5.6 Rate Regulations (Cont'd)5.6.11 DS3 High Capacity Service [1] (Cont'd)(F) Notification of Discontinuance

Notice of discontinuance must be given by the customer at least thirty days prior to actual discontinuance. Monthly charges will apply for a period of thirty days from the date the Company receives discontinuance notification or until the requested discontinuance date, whichever period is longer.

(G) Upgrade to Higher Speed Service

Customers may elect to upgrade DS3 service(s) to a higher speed during a first liability period or subsequent liability period. The upgraded service will be subject to all appropriate NRCs.

If the following conditions exist, no termination liabilities will be applied:

- Both the existing and the new services are provided solely by the Company.
- The order to discontinue a service at an existing speed or capacity and the order for the upgraded service are received by the Company at the same time.
- The new service will be provided at the same customer location(s) as the discontinued service.
- The fixed-period plan for the upgraded service(s) meets or exceeds the remaining length of the existing fixed-period plan.
- The total monthly rate of the new agreement is equal to or greater than the total monthly rate of the existing agreement period.
- The monthly rates for the upgraded services and/or service elements will be those in effect at the time of the service upgrade. The upgraded service will be subject to all appropriate nonrecurring charges.
- Termination liability charges will not apply as long as the upgraded service remains connected at the same point of termination(s) or meets the requirements set forth in Section 5.6.4(B)2.

[1] Effective May 16, 2019 the DS3 High Capacity 1, 3, 5 and 7 Year Rate Plans will be grandfathered until the expiration date of the current term. Term renewals will not be offered on these plans going forward as of this effective date. Upon expiration of the current term, rates will revert to month-to-month.



## FACILITIES FOR INTERSTATE ACCESS

5. SPECIAL ACCESS (Cont'd)5.6 Rate Regulations (Cont'd)5.6.12 Optional Payment Plan (OPP)

Effective May 16, 2019 the following Optional Payment Plan (OPP) will be grandfathered until the expiration date of the current term. Term renewals will not be offered on these plans going forward as of this effective date. Upon expiration of the current term, rates will revert to month-to-month.

(A) General

- (1) The terms and conditions specified herein are applicable to FT1 and DDS services. Additional terms and conditions for FT1 OPP are set forth in 5.6.12(H). Additional terms and conditions for DDS are set forth in 5.6.12(I).
- (2) Only the Channel Termination rate element is available under an OPP. All other associated rate elements or additional features are available at the standard month-to-month tariffed rates and regulations.
- (3) FT1 OPP Channel Termination rates will not be greater than standard month-to-month Channel Termination rates.
- (4) Three year and five year OPP rates will be equal to or less than the one year OPP rates. Decreases to the one year OPP will flow through to the three year and five year OPP.
- (5) Payment periods of one year, three year, and five years are available to all customers at the applicable rates set forth in 5.7.5(B), 5.7.8 or 5.7.9 regardless of when they subscribe to an OPP arrangement.
- (6) The customer must designate on the ASR the payment period for the OPP.
- (7) Inside moves, provided in accordance with 5.6.4, will not incur termination liability charges.
- (8) Outside moves provided in accordance with 5.6.4(B)(2) will allow the customer to retain the same OPP payment period. Any other move will be treated as a disconnect of the service and termination liability charges will apply.

## FACILITIES FOR INTERSTATE ACCESS

5. SPECIAL ACCESS (Cont'd)5.6 Rate Regulations (Cont'd)5.6.12 Optional Payment Plan (OPP)(B) Changes in Length of OPP Period

Prior to the completion of the selected OPP period, the customer may elect to convert to a new OPP period of the same or different length, subject to the following conditions:

- No credit toward the new payment period will be given for payments made under the original OPP arrangement.
- Nonrecurring charges will not be reapplied for existing service(s).
- If the new OPP period is shorter in length than the time remaining under the existing OPP, the change to the new OPP period constitutes a disconnect of the existing OPP service and termination liability charges apply.

(C) Renewal Options

- (1) At the expiration of an OPP period, the Company will automatically renew the service at the same OPP period unless the customer chooses to convert to a different OPP period, convert to month-to-month rates or discontinue service.
- (2) Conversion to a different OPP period will require the customer to submit a change order ASR. Conversion to a different OPP period will be allowed without application of any nonrecurring or ordering charges.
- (3) Conversion to month-to-month rates will be treated as a disconnect of service and establishment of new service. If no other changes are ordered, no NRCs will apply.

(D) Notification of Discontinuance

An ASR for discontinuance of an OPP arrangement must be received by the Company at least thirty (30) days prior to actual disconnect of service. Monthly charges will apply for a period of thirty (30) days from the date the Company receives disconnect notification or until the requested disconnect date, whichever period is longer.

## FACILITIES FOR INTERSTATE ACCESS

5. SPECIAL ACCESS (Cont'd)5.6 Rate Regulations (Cont'd)5.6.12 Optional Payment Plan (OPP) [1] (Cont'd)(E) Upgrade to Higher Speed Service

Customers may elect to upgrade service(s) to a higher speed during an OPP period, subject to the following conditions:

- The upgraded service will be subject to all appropriate nonrecurring charges.
- Termination liability charges will not apply as long as the upgraded service remains connected at the same point of termination(s) or meets the requirements set forth in 5.6.4(B)(2).
- If the upgrade involves establishing a multiplexing arrangement, termination liability charges will not apply if the hub wire center is the same one associated with the customer designated location.

(F) Termination Liability

When an OPP service is discontinued prior to the end of the period, termination liability charges, as set forth below, will apply based on the remainder of the OPP period in effect at the time of disconnect.

One Year OPP - 50% of any remaining portion of the first year's recurring charges.

Three Year OPP - 50% of any remaining portion of the first year's recurring charges. In addition, for any remaining portion of the second and third years, the customer will be liable for 10% of the total monthly recurring charges in that time period.

Five Year OPP - 50% of any remaining portion of the first year's recurring charges. In addition, for any remaining portion of the second through fifth years, the customer will be liable for 20% of the total monthly recurring charges in that time period.

[1] Effective May 16, 2019 the Optional Payment Plan (OPP) will be grandfathered until the expiration date of the current term. Term renewals will not be offered on these plans going forward as of this effective date. Upon expiration of the current term, rates will revert to month-to-month.

## FACILITIES FOR INTERSTATE ACCESS

5. SPECIAL ACCESS (Cont'd)5.6 Rate Regulations (Cont'd)5.6.12 Optional Payment Plan (OPP) [1] (Cont'd)(G) Termination Without Liability

During an OPP period, should the currently effective rate for a customer's service increase, the customer may, at their option, terminate the OPP arrangement without penalty or liability.

(H) OPP for FT1 Service

A customer may change from DS1 OPP service to an FT1 OPP service subject to the following rate applications. Also, a customer may change the number of channels of an N x 56 Kbps or N x 64 Kbps service to another higher value of N (where N = 2, 4 or 6), subject to the following rate applications:

- The changed service will be subject to all appropriate nonrecurring charges.
- Termination liability charges will not apply as long as the changed service remains connected at the same point of termination(s) or meets the requirements of 5.6.4(B)(2).
- If the change involves establishing a multiplexing arrangement, termination liability charges will not apply if the hub wire center is the same one associated with the customer designated location.

[1] Effective May 16, 2019 the Optional Payment Plan (OPP) will be grandfathered until the expiration date of the current term. Term renewals will not be offered on these plans going forward as of this effective date. Upon expiration of the current term, rates will revert to month-to-month.

## FACILITIES FOR INTERSTATE ACCESS

5. SPECIAL ACCESS (Cont'd)5.6 Rate Regulations (Cont'd)5.6.12 Optional Payment Plan (OPP) [1] (Cont'd)(I) OPP for DDS

- (1) For conversion of existing month-to-month DDS to an OPP arrangement, the customer will be required to submit a change order ASR to convert to the OPP. No service or billing interruption will occur when a customer converts from month-to-month rates to OPP rates. If no other changes to the service are ordered, no charges will apply.
- (2) A customer may upgrade from a DDS OPP to an FT1 OPP subject to the following rate applications:
  - The changed service will be subject to all appropriate nonrecurring charges.
  - Termination liability charges will not apply as long as the changed service remains connected at the same point(s) of termination or meets the requirements of 5.6.4(B)(2).

[1] Effective May 16, 2019 the Optional Payment Plan (OPP) will be grandfathered until the expiration date of the current term. Term renewals will not be offered on these plans going forward as of this effective date. Upon expiration of the current term, rates will revert to month-to-month.

## FACILITIES FOR INTERSTATE ACCESS

5. SPECIAL ACCESS (Cont'd)5.6 Rate Regulations (Cont'd)5.6.13 Four-Wire Voiceband and Digital Data Service (DDS) Rate Stability Plan (RSP)

Effective May 16, 2019 the following Four-Wire Voiceband and Digital Data Service Rate Stability Plan (RSP) will be grandfathered until the expiration date of the current term. Term renewals will not be offered on these plans going forward as of this effective date. Upon expiration of the current term, rates will revert to month-to-month.

(A) Description

The Four-Wire Voiceband and DDS RSP will allow customers to stabilize their monthly recurring rates (MRCs) for Four-Wire Voiceband and DDS Channel Terminations and associated Voiceband and DDS Special Transport. This service is offered for a fixed service period at the rates specified in Section 5.7.15. The RSP allows customers to select a service commitment period during which the rates will be stabilized. The service commitment periods are 3 years or 5 years, which must be specified in writing at the time of enrollment.

The RSP is available to customers who qualify for the Plan's eligibility requirements and agree to the Plan's terms and conditions.

Customers of the Plan will not be subject to Company initiated rate increases during their service commitment period. Rate changes may occur as a result of FCC action.

Four-Wire Voiceband and DDS RSP rates will not be greater than standard month-to-month Four-Wire Voiceband and DDS Channel Termination rates and associated Voiceband and DDS Special Transport rates.

## FACILITIES FOR INTERSTATE ACCESS

5. SPECIAL ACCESS (Cont'd)5.6 Rate Regulations (Cont'd)5.6.13 Four-Wire Voiceband and Digital Data Service (DDS) Rate Stability Plan (RSP)(B) Eligibility Requirement

The eligibility requirement for RSP is a minimum combined national commitment level of 500 Four-Wire Voiceband and DDS Channel Terminations. These Channel Terminations must be interstate services and provided by the BLOC's in their serving areas. Any associated Special Transport is also subject to the terms and conditions of the RSP.

At an annual review, if the customer has committed to more than the minimum number of 500 Channel Terminations required, an allowance of minus 2% or plus 5% will be considered as having met the commitment level.

When the customer elects to enroll in an RSP, they must specify, in writing, the enrollment date (which will be the anniversary date) and the commitment level. The specified enrollment date must be within 30 days of receipt by the Company. By the specified date, the customer must issue ASRs to add Channel Terminations to the RSP and/or convert month-to-month Channel Terminations to the RSP to fall within the commitment range specified above.

Besides the eligibility requirement, customers of this plan are also subject to the terms and conditions specified in Section 5.6.13(C).

(C) RSP Terms and Conditions

(1) Written notice must be submitted by the customer to change the commitment level of Channel Terminations. If, as the result of increasing or decreasing the commitment level, service is changed from the RSP to a month-to-month arrangement or from a month-to-month arrangement to the RSP, an ASR will be required within 30 days for all services changed. Only one RSP will be allowed per customer. Penalties for decreasing the commitment level are discussed in 5.6.13(C)(4).

## FACILITIES FOR INTERSTATE ACCESS

5. SPECIAL ACCESS (Cont'd)5.6 Rate Regulations (Cont'd)5.6.13 Four-Wire Voiceband and Digital Data Service (DDS) Rate Stability Plan (RSP) [1]  
(Cont'd)(C) RSP Terms and Conditions

- (2) Each customer's RSP will be reviewed annually. The customer will be notified in writing as to the status of the RSP. This notification will inform the customer of any RSP Channel Terminations that must be converted. If the customer has increased the number of Channel Terminations from the initial commitment beyond the range specified in 5.6.13(B), he will have the option of increasing the commitment level for the remainder of the plan. If the customer chooses not to increase the commitment level of Channel Terminations for the remaining year(s) of the plan, he must convert the increased number of Channel Terminations to standard month-to-month Channel Terminations to a level within the range specified in 5.6.13(B). The customer may decrease the commitment level at the time of the annual review and pay the applicable penalties for the amount of Channel Terminations being decreased. The customer will have 30 days from the receipt of this notification to convert Channel Terminations.
- (3) If a service has two Channel Terminations, to include this service as part of the RSP, both Channel Terminations must be in the RSP. RSP rates for Special Transport are only applicable when the associated Channel Terminations are included in the RSP.

After enrolling in the plan, the customer may add or delete RSP Channel Terminations at any time during the plan.

- (4) When the number of RSP Channel Terminations at the annual review is less than the acceptable commitment range, penalty charges will apply, based on the difference between the commitment level less 2% and the number of RSP Channel Terminations in effect at the annual review. For example, if the commitment level is 100 and the customer has 90 RSP Channel Terminations at the time of the annual review, the penalties described below will be applied to the difference of 98 (2% less than 100) and 90, which would be 8 in this example.

[1] Effective May 16, 2019 the Four-Wire Voiceband and Digital Data Service Rate Stability Plan (RSP) will be grandfathered until the expiration date of the current term. Term renewals will not be offered on these plans going forward as of this effective date. Upon expiration of the current term, rates will revert to month-to-month.



## FACILITIES FOR INTERSTATE ACCESS

5. SPECIAL ACCESS (Cont'd)5.6 Rate Regulations (Cont'd)5.6.13 Four-Wire Voiceband and Digital Data Service (DDS) Rate Stability Plan (RSP) [1]  
(Cont'd)(C) RSP Terms and Conditions (Cont'd)

## (4) Continued

The penalty charged is equal to the unweighted average of the customer's applicable RSP Four-Wire Voiceband Channel Termination and DDS Channel Termination monthly rates multiplied by the deficient number of Channel Terminations.

(D) RSP Nonrecurring Charges

No nonrecurring charge will apply for the ASRs processed to convert existing Channel Terminations to or from the RSP. All applicable Special Access NRCs will apply for ASRs processed to add new Channel Terminations. Refer to Section 5.7.2 for Voiceband Channel Termination NRCs and Section 5.7.5 for Digital Data Service Channel Termination NRCs.

(E) RSP Services

This Plan is offered only for Four-Wire Voiceband and Digital Data Service (DDS).

[1] Effective May 16, 2019 the Four-Wire Voiceband and Digital Data Service Rate Stability Plan (RSP) will be grandfathered until the expiration date of the current term. Term renewals will not be offered on these plans going forward as of this effective date. Upon expiration of the current term, rates will revert to month-to-month.

## FACILITIES FOR INTERSTATE ACCESS

5. SPECIAL ACCESS (Cont'd)5.6 Rate Regulations (Cont'd)5.6.13 Four-Wire Voiceband and Digital Data Service (DDS) Rate Stability Plan (RSP) [1]  
(Cont'd)(F) RSP Application(1) Rate Elements Subject to the Plan

The RSP stabilizes the MRCs for Four-Wire Voiceband Channel Terminations, DDS Channel Terminations, and their associated Voiceband and DDS Special Transport MRCs. The MRCs for these rate elements will not be increased by initiation of the Company from the rates in effect as of the RSP enrollment date for the duration of the service commitment period. The RSP enrollment date is the date on which the RSP customer signs a written agreement for RSP and otherwise meets the Plan's eligibility requirements.

All RSP customers will pay the same RSP rate at any given point in time. However, each RSP customer will have only one RSP enrollment date, which will apply to all of the customer's rate elements subject to the Plan. This is regardless of whether services were existing and converted to the RSP, added at the time of enrollment, or added subsequently during the RSP service commitment period.

Before the expiration of a customer's RSP service commitment period, the RSP may be replaced by a new RSP at the tariffed rates currently in effect. The customer will not incur any penalties associated with their current plan if the elected service period is equal to or greater than the time remaining on the current RSP. For any new services added to the Plan, the MRCs will be at the rate in effect when the customer elects the new plan. However, billing for these services will not begin until the services have been installed.

The RSP does not apply to NRCs associated with Four-Wire Voiceband and DDS, supplemental features and multiplexing arrangements.

[1] Effective May 16, 2019 the Four-Wire Voiceband and Digital Data Service Rate Stability Plan (RSP) will be grandfathered until the expiration date of the current term. Term renewals will not be offered on these plans going forward as of this effective date. Upon expiration of the current term, rates will revert to month-to-month.

## FACILITIES FOR INTERSTATE ACCESS

5. SPECIAL ACCESS (Cont'd)5.6 Rate Regulations (Cont'd)5.6.13 Four-Wire Voiceband and Digital Data Service (DDS) Rate Stability Plan (RSP) [1]  
(Cont'd)(F) RSP Application (Cont'd)(2) RSP Expiration

At the end of the service commitment period, the customer may either continue the services at non-RSP rates in effect or elect a new RSP. If the customer chooses to convert to a new RSP, the new service period will begin the day following the expiration of the old Plan. The RSP rate for the new Plan will be at those in effect at the beginning of the new service period. If the customer fails to make this selection, the Company will notify the customer and continue one additional month of RSP billing. If the customer does not notify the Company of its intentions within 30 days from the expiration date of the RSP, the services under the plan will revert to general tariffed rates.

(3) Upgrade to Higher Capacity Service

The customer may upgrade service to a high capacity service during the RSP period. The upgraded service will be subject to all appropriate NRCs.

If both of the following conditions exist, the commitment level will be decreased by the number of RSP Channel Terminations that are upgraded to a high capacity service.

- The customer must notify the Company in writing in addition to issuing an ASR.
- The high capacity service period must be equal to or longer in length than the time remaining under the RSP.

[1] Effective May 16, 2019 the Four-Wire Voiceband and Digital Data Service Rate Stability Plan (RSP) will be grandfathered until the expiration date of the current term. Term renewals will not be offered on these plans going forward as of this effective date. Upon expiration of the current term, rates will revert to month-to-month.

## FACILITIES FOR INTERSTATE ACCESS

5. SPECIAL ACCESS (Cont'd)5.6 Rate Regulations (Cont'd)5.6.14 DS1 Term Volume Plan (TVP)

Effective May 16, 2019 the following DS1 Term Volume Plan (TVP) will be grandfathered until the expiration date of the current term. Term renewals will not be offered on these plans going forward as of this effective date. Upon expiration of the current term, rates will revert to month-to-month.

(A) Description

The DS1 Term Volume Plan (TVP) allows customers discounts, which are applied to DS1 Channel Terminations based upon a volume and term commitment. The customer's DS1 Channel Termination commitment level can be established on a nationwide basis or negotiated between the customer and the Company (i.e., state basis, regional basis, etc.). The TVP is offered for a 1, 2, 3 or 5 year term commitment period. All of the customer's TVP DS1 Channel Terminations will be billed at the same rate, based upon the state where the service is located, the length of the term selected by the customer, and the threshold level in which the commitment quantity falls. All other associated rate elements or additional features are available at the standard month-to-month rates and regulations.

During the TVP term, the customer may elect to increase the term or commitment level of the plan without any Termination Liability, provided there is no lapse of time between the effective date of the increase and the termination of the previously effective term or commitment quantity.

The new term length begins on the same start day as the term length it replaces. There will not be any retroactive adjustments of a discount due to a customer-initiated change in term or commitment quantity.

(B) Rate Application

For conversion of existing month-to-month DS1 service to a TVP arrangement, the customer will be required to submit written notification or a change order ASR to convert to the TVP. No service or billing interruption will occur when a customer converts from month-to-month rates to a TVP. If no other changes to the service(s) are ordered, no charges will apply.

If a change involves establishing a multiplexing arrangement, termination liability charges will not apply if the hub wire center and the serving wire center of the customer designated location are the same.

## FACILITIES FOR INTERSTATE ACCESS

5. SPECIAL ACCESS (Cont'd)5.6 Rate Regulations (Cont'd)5.6.14 DS1 Term Volume Plan (TVP) [1] (Cont'd)(C) Rate Changes

Rate changes in the TVP monthly recurring DS1 Channel Termination rates will be passed on to subscribers of the plan. However, during the TVP period, should the rates increase, the customer may, at his/her option, terminate the TVP arrangement without penalty or liability, unless the increase is a result of FCC action.

(D) Threshold Levels

Two or more DS1 Channel Terminations are required to qualify for a TVP. Rates are applied based on the following DS1 Channel Termination threshold levels: 2-60, 61-120, 121-240, 241-500, 501-1000, 1001-3000, 3001-6000, 6001-11,000 and Over 11,000.

(E) Changes to Commitment Quantity or Term

At any time during the plan term, the customer may increase the commitment quantity of DS1 Channel Terminations or commitment term to receive a lower threshold rate by submitting written notification to the Company.

When a penalty is assessed at the annual review, as set forth in 5.6.14(I), the number of DS1 Channel Terminations in service will become the commitment quantity for the subsequent years' annual review.

The customer will be entitled to be assessed at a lower DS1 commitment level, without penalty if the Company sells off its assets in specific states.

(F) TVP Plan Enrollment

When the customer elects to enroll in a TVP he/she must specify, in writing, the enrollment date (which will be the anniversary date) and the DS1 Channel Termination commitment quantity. The specified enrollment date must be within 30 days of receipt. By the specified date, the customer must submit a request in writing or issue ASR(s) to add DS1 Channel Terminations to the TVP and/or convert month-to-month arrangement DS1 Channel Terminations to the TVP to fall within the commitment quantity specified.

[1] Effective May 16, 2019 the DS1 Term Volume Plan (TVP) will be grandfathered until the expiration date of the current term. Term renewals will not be offered on these plans going forward as of this effective date. Upon expiration of the current term, rates will revert to month-to-month.

## FACILITIES FOR INTERSTATE ACCESS

5. SPECIAL ACCESS (Cont'd)5.6 Rate Regulations (Cont'd)5.6.14 DS1 Term Volume Plan (TVP) [1] (Cont'd)(G) Annual Review

Each customer's TVP will be reviewed annually. The customer will be notified in writing as to the status of the TVP. If the in-service DS1 Channel Termination quantity falls below the commitment quantity, an allowance of 3% will be considered as having met the commitment quantity. Where the customer does not meet the minimum quantity of DS1 Channel Terminations in service, penalties will be assessed as set forth under 5.6.14(I).

If the number of DS1 Channel Terminations increase from the initial commitment, the customer will have the option of increasing the commitment level for the remainder of their TVP. If the customer chooses not to increase the commitment level, he/she may convert the increased number of DS1 Channel Terminations to a monthly plan or a second TVP plan.

The customer may decrease the commitment level at the time of the annual review and pay the applicable penalties for the amount of DS1 Channel Terminations being decreased. Penalties will apply as set forth in 5.6.14(I).

The customer will have 30 days from receipt of notification to convert DS1 Channel Terminations. If the customer does not take action during the 30 day period, the commitment level will be automatically changed to the number of TVP DS1 Channel Terminations in effect at the annual review.

(H) TVP Conditions

If a DS1 service (circuit) consists of two DS1 Channel Terminations, both DS1 Channel Terminations must be in the TVP.

After enrolling in the plan, the customer may delete or add DS1 Channel Terminations rated at the specified term period/threshold level rate at any time during the plan. For example, if the customer subscribes to a 2 year TVP at the 61-120 DS1 Channel Termination threshold level, DS1 Channel Terminations may be added at any time at the 2 year 61-120 threshold rate level.

[1] Effective May 16, 2019 the DS1 Term Volume Plan (TVP) will be grandfathered until the expiration date of the current term. Term renewals will not be offered on these plans going forward as of this effective date. Upon expiration of the current term, rates will revert to month-to-month.

## FACILITIES FOR INTERSTATE ACCESS

5. SPECIAL ACCESS (Cont'd)5.6 Rate Regulations (Cont'd)5.6.14 DS1 Term Volume Plan (TVP) [1] (Cont'd)(I) Penalties for Failing To Meet Commitment

When the number of TVP DS1 Channel Terminations at the annual review is less than the commitment quantity minus 3%, the penalty will be the lowest TVP rate for the current threshold in the states where the service is located, multiplied by the shortfall multiplied by 4 months.

For example, if the commitment quantity is 100 and the customer has 90 DS1 TVP Channel Terminations at the time of the annual review, the penalty described below will be applied to the shortfall difference of 97 (3% less than 100), and 90. Customer has DS1 Channel Terminations in Alabama and Missouri.

- Current threshold level is 61-120, 5 Year term
- In-service quantity at annual review = 90
- Shortfall is  $97 - 90 = 7$
- Penalty is calculated as follows:

$\$150.00^* \times 7 \times 4 \text{ months} = \$4,200.00 \text{ penalty}$

\* Lowest TVP MRC applied the customer

(J) TVP Nonrecurring Charge

Customers subscribing to a TVP will be assessed a nonrecurring charge per DS1 Channel Termination except when converting standard month-to-month DS1 Channel Terminations to a TVP.

(K) Changes in Length of a TVP Period

Prior to the expiration of a TVP period, the customer may elect to convert to a new TVP period of the same or different length, subject to the following conditions:

- no credit will be given for the new payment period for payments made under the original TVP arrangement
- NRCs will not be reapplied for existing service(s)
- if the new TVP period is shorter in length than the time remaining under the existing TVP, the change to the new TVP period constitutes a disconnect of the existing TVP and termination liability charges will apply as set forth under 5.7.16.

[1] Effective May 16, 2019 the DS1 Term Volume Plan (TVP) will be grandfathered until the expiration date of the current term. Term renewals will not be offered on these plans going forward as of this effective date. Upon expiration of the current term, rates will revert to month-to-month.

## FACILITIES FOR INTERSTATE ACCESS

5. SPECIAL ACCESS (Cont'd)5.6 Rate Regulations (Cont'd)5.6.14 DS1 Term Volume Plan (TVP) [1] (Cont'd)(L) Renewal Options

At the expiration of a TVP period, the customer may select a new TVP period or convert to a month-to-month payment plan. If the customer fails to make this selection, the Company will notify the customer and continue two additional months of TVP billing. If the customer does not select a new payment plan within 60 days from the expiration date, billing will remain at the current threshold level and a new TVP period will begin based on the previously effective term and quantity commitment. All terms and conditions, including Termination Liabilities will apply to the new TVP period.

(M) Upgrade to Higher Speed Service

The customer may upgrade service to a higher speed during a TVP period. The upgraded service will be subject to all appropriate NRCs.

If the following conditions exist, no termination liabilities will be applied for the decreased number of TVP Channel Terminations that are upgraded to a higher speed service.

- The customer must notify the Company in writing, in addition to the ASR.
- The higher speed service period must be equal to or longer in length than the time remaining under the TVP.
- The upgraded service remains connected at the same point(s) of termination.

When TVP DS1 Channel Terminations are upgraded to an Optical Networking arrangement, the number of DS1 Channel Terminations upgraded will remain in the quantity count for the purpose of determining the applicable threshold level rate

(N) Termination Liability

When a TVP arrangement is discontinued prior to the end of the commitment period, termination liability charges, as set forth below, will apply based on the remainder of the TVP period in effect at the time of disconnect.

One Year TVP - 50% of any remaining portion of the first year's recurring charges.

Two Year TVP - 50% of any remaining portion of the first year's recurring charges. In addition, for any remaining portion of the second year, the customer will be liable for 5% of the total monthly recurring charges in that period.

Three Year TVP - 50% of any remaining portion of the first year's recurring charges. In addition, for any remaining portion of the second and third years, the customer will be liable for 10% of the total monthly recurring charges in that time period.

Five Year TVP - 50% of any remaining portion of the first year's recurring charges. In addition, for any remaining portion of the second through fifth years, the customer will be liable for 20% of the total monthly recurring charges in that time period.

[1] Effective May 16, 2019 the DS1 Term Volume Plan (TVP) will be grandfathered until the expiration date of the current term. Term renewals will not be offered on these plans going forward as of this effective date. Upon expiration of the current term, rates will revert to month-to-month.



## FACILITIES FOR INTERSTATE ACCESS

5. SPECIAL ACCESS (Cont'd)5.6 Rate Regulations (Cont'd)5.6.14 DS1 Term Volume Plan (TVP) [1] (Cont'd)(O) Termination Without Liability

During a TVP period, should the currently effective rate for a customer's service increase, the customer may, at their option, terminate the TVP arrangement without penalty or liability, unless the increase is a result of FCC action.

5.6.15 Reserved for Future Use5.6.16 Reserved for Future Use

[1] Effective May 16, 2019 the DS1 Term Volume Plan (TVP) will be grandfathered until the expiration date of the current term. Term renewals will not be offered on these plans going forward as of this effective date. Upon expiration of the current term, rates will revert to month-to-month.

## FACILITIES FOR INTERSTATE ACCESS

5. SPECIAL ACCESS (Cont'd)5.6 Rate Regulations (Cont'd)5.6.17 LAN Extension Service(A) General

LAN (Local Area Network) Extension Service, LES, is not available in Alabama or Missouri but it provides fiber transport connectivity between two customer designated locations (CDLs). LES is made available to network service providers, herein referred to as the customer, for provision of LES to their customers (end users).

LES is a point-to-point service, offered with a 10 Mbps, 100 Mbps or 1 Gbps Ethernet interface connection, available where facilities and conditions permit. For locations where a customer requests LES and fiber facilities are not available, special construction charges may apply as set forth in Brightspeed Local Operating Companies Tariff F.C.C. No. 5.

The regulations and rates specified herein are in addition to the applicable regulations and rates specified in other sections of this service guide.

(B) Service Description

LES is provisioned over two dedicated fiber strands between the customer and its end user's location. At the CDL, LES is connected, as specified by the customer, through the LES network interface. The LES network interface converts the optical signal to an electrical Ethernet signal at speeds of 10Mbps or 100 Mbps. The LES network interface converts the optical signal to an electrical Ethernet signal at speeds of 10 Mbps or 100 Mbps. The LES 1 Gbps interface is an optical signal.

The Company's equipment at the customer's CDL must be on conditioned power circuits (surge protected); the Company recommends an uninterrupted power supply (UPS).

The Company does not provide any service guarantees for LES, including credit for service outages.

LES is provisioned in accordance with the Service Date Intervals as set forth in Section 3.2.1.

## FACILITIES FOR INTERSTATE ACCESS

5. SPECIAL ACCESS (Cont'd)5.6 Rate Regulations (Cont'd)5.6.17 LAN Extension Service (Cont'd)(C) Technical Specifications - Limitations

- (1) The fiber optic specifications are single mode, 1310nm with the following dB loss:

10Mbps Ethernet – 20dB loss or less

100Mbps Ethernet – 26dB loss or less

1Gbps Ethernet – 18dB loss or less

- (2) The fiber optic specifications are single mode 1550nm with the following dB loss for:

1Gbps Ethernet (extended distance) - 26dB loss or less

- (3) The dB loss is measured to include the special transport facility when applicable and any local and intra-building fibers used in the provision of LES.

(D) Responsibilities and Rights of the Company

In addition to the general conditions described in Section 2 preceding:

- The Company will provide the necessary fiber converter at the customer's designated locations to meet the interface requirements specified on the order for service.
- The Company is responsible for service up to and including the network interface and the cross connect. The Company's responsibility is limited to the furnishing of communications facilities and switches suitable for LES.
- In order to perform software updates and other maintenance, it may be necessary to take the wire centers associated with LES out of service during the Company's maintenance window. The Company will provide customers reasonable and timely notification to minimize impacts to the customer's service. The Company reserves the right to temporarily interrupt LES at other times in emergency situations.

## FACILITIES FOR INTERSTATE ACCESS

5. SPECIAL ACCESS (Cont'd)5.6 Rate Regulations (Cont'd)5.6.17 LAN Extension Service (Cont'd)(E) Responsibilities of the Customer

In addition to the general conditions described in Section 2 preceding:

- The customer is responsible for all wiring and connections to its side of the network interface required for connecting the LAN to the LES equipment.
- The customer is responsible for the installation, operation and maintenance of any customer provided equipment.
- The customer must provide a protected path for all network fibers on private property, sufficient AC power to network interface equipment, access to all sites as needed by the Company personnel to perform services and a secure environment for the network equipment.
- The customer must provide a relay rack or wall space for mounting of the network interface device.
- The customer must provide connecting facility assignment, CFA, to the designated fiber cross connect in an EIS arrangement.

## FACILITIES FOR INTERSTATE ACCESS

5. SPECIAL ACCESS (Cont'd)5.6 Rate Regulations (Cont'd)5.6.17 LAN Extension Service (Cont'd)(F) Rate Regulations

LES service is not available in Alabama or Missouri. All LES rate elements with the exception of the LES Cross Connect, are offered in term plans of three and five years. The customer must designate on the Access Service Request (ASR) the term commitment, if applicable for LES.

- The customer may, at any time, upgrade the LES transmission rate without incurring termination liability as long as a term plan of equal or greater length than the original term plan is established.
- The customer may at any time request to change from an existing term to a new term of equal or greater length without charge.
- Cancellation of the service in whole or in part by the customer prior to the establishment thereof, will require payment to the Company of an amount equal to the total nonrecurring charges for the services ordered.
- Rate elements must be ordered under the same service term period.
- Inside moves, provided in accordance with Section 5.6.4(A), will not incur termination liability charges.
- Outside moves, provided in accordance with Section 5.6.4(B), will allow the customer to retain the same payment period. Any other move will be treated as a disconnect of the service and termination liability charges will apply.
- Once the term has expired, prevailing rates for the expiring term plan will apply.
- The Special Access Surcharge set forth under 5.6.9 does not apply to LES connections.

(1) Minimum Period

The minimum term for LES is three years.

## FACILITIES FOR INTERSTATE ACCESS

5. SPECIAL ACCESS (Cont'd)5.6 Rate Regulations (Cont'd)5.6.17 LAN Extension Service (Cont'd)(F) Rate Regulations (Cont'd)(2) Rate Elements(a) LES Special Access Line (SAL)

A nonrecurring charge and a monthly rate apply based on each 10 Mbps, 100 Mbps or 1 Gbps LES SAL termination. The LES SAL provides for the communications path between a customer's designated location and the serving wire center of that location. Included, as part of the LES SAL is a converter interface arrangement, which defines the technical characteristics associated with the LES SAL. The LES SAL is available as a three or five year term.

(b) LES Transport

A monthly charge applies per airline mile for the transmission facilities between Company wire centers when the customer and its end users are not located in the same serving wire center. LES Transport is available as a 10 Mbps, 100 Mbps or 1 Gbps arrangement. LES Transport is available as a three or five year term. The LES Transport term must equal the term of the LES SAL.

(3) Changes in Length of LES Period

Before the completion of the selected LES period, the customer may elect to convert to a new LES period of the same or different length, subject to the following conditions:

- No credit toward the new payment period will be given for payments made under the original LES arrangement.
- If the new LES period is shorter in length than the time remaining under the existing LES, the change to the new LES period constitutes a discontinuance of the existing LES service and termination liability charges apply.

## FACILITIES FOR INTERSTATE ACCESS

5. SPECIAL ACCESS (Cont'd)5.6 Rate Regulations (Cont'd)5.6.17 LAN Extension Service (Cont'd)(F) Rate Regulations (Cont'd)(4) Expiration of Minimum Service Period

Upon expiration of a Less term, the customer may choose a new LES term, terminate the service or continue with the rates, charges, terms and conditions in effect at the end of the expiring term.

When a customer retains LES for the duration of a term, the termination liabilities expire. As long as the customer makes no physical changes to the configuration of service(s), the customer will no longer be liable for early termination discontinuance charges regardless of the minimum service period rate level.

(5) Termination Liability

If the customer terminates service in whole or in part prior to the end of the selected term plan, a termination charge applies that is equal to the applicable monthly recurring rate for the terminated service multiplied by the number of months remaining in the unexpired portion of the term plan. Minimum period charges may also apply.

(6) Termination Without Liability

During a LES period, should the currently effective rate for a customer's service increase, the customer may discontinue service without liability as long as the Company is notified of the customer's intent within sixty days of the rate increase and service is discontinued within ninety days of the increases.

## FACILITIES FOR INTERSTATE ACCESS

5. Special Access Service (Cont'd)5.6 Rate Regulations (Cont'd)5.6.18 Ethernet Transport

The rates and charges for Ethernet Transport (ET) service are set forth in 5.7.18 following and are in addition to any applicable rates and charges set forth in any other sections of this service guide. Nonrecurring charges and monthly recurring rates applicable for ET service are billed in advance.

- (A) Nonrecurring charges are one-time charges that apply for a specific work activity (i.e., installation of service) and are developed at full cost recovery on a labor hours per labor time basis. Nonrecurring charges will apply for Ethernet Transport regardless of the option selected (i.e., month-to-month, one, three or five year commitment). However, if at the end of the one, three or five year commitment period, the customer elects to renew their commitment plan or revert to the month-to-month rates, a nonrecurring charge will not apply for this renewal.
- (B) Monthly recurring charges are flat recurring rates that apply each month or fraction thereof that a specific rate element is provided regardless of the amount of usage. For billing purposes, each month is considered to have 30 days.
- (C) Ethernet Transport service is available on a month-to-month basis or for a period of one, three or five years. All ET arrangements will begin in month one. If the customer requests that the service be disconnected prior to the expiration of the one, three or five year service period selected, termination liability charges equal to 50% of the remaining months of the term will apply. For example, a customer disconnecting in the 12th month of a 3 year plan will be charged 50% of the remaining 24 months of billing. The Federal Government and its authorized agents are exempt from the 50% termination liability penalty charge if service is discontinued prior to the expiration of the one, three or five year minimum commitment period.

Additionally, customers may disconnect ET service, without penalty, should the total monthly recurring rates associated with ET service increase by 10% or more at any one time. The customer must notify the Company in writing within 90 days after the effective date of the rate increase if they elect to discontinue service. Rate decreases will automatically be applied to the monthly recurring rates for the remainder of the service period.



## FACILITIES FOR INTERSTATE ACCESS

5. Special Access Service (Cont'd)5.6 Rate Regulations (Cont'd)5.6.18 Ethernet Transport (Cont'd)

## (C) (Cont'd)

If the customer does not specify renewal terms in writing 90 days prior to the expiration of the one, three or five year period, the commitment period and ET service rates in effect at the time of expiration will automatically renew. Alternatively, 90 days prior to the expiration of the one, three or five year period the customer may specify in writing their intent to continue use of the services under month-to-month rates. The customer can terminate ET service at the end of the minimum commitment period with no penalty or obligation to continue the service. Further, if the customer notifies the Company in writing 90 days prior to the expiration date of their minimum commitment period with their intent to not renew their ET service, the customer will have six (6) months after the expiration date to submit their disconnect order(s). If the customer fails to submit their disconnect order(s), by the end of the six (6) month period, the commitment period in effect at the time of the original expiration period will automatically renew at the current service guide rates. If the customer submits their disconnect orders(s) after the six (6) month period, termination liability charges will apply. Termination liability charges will be calculated at 50% of the monthly recurring charges for the remaining months of the commitment period up to a maximum of twelve (12) months. Time from the expiration of the original commitment period until the disconnect order(s) are received will apply for calculation of the termination liability charges.

Customers may upgrade Ethernet Transport without incurring termination liability charges under the following circumstances:

- (1) The order for the disconnect of the existing Ethernet Transport and the order for the upgraded Ethernet Transport must be received at the same time.
- (2) The new Ethernet Transport is provided between the same customer and central office locations as the discontinued service.
- (3) The service period of the new Ethernet Transport is equal to or greater than the service period of the existing Ethernet Transport service.

5.6.19 Reserved for Future Use

## FACILITIES FOR INTERSTATE ACCESS

5. Special Access Service (Cont'd)5.6 Rate Regulations (Cont'd)5.6.20 Ethernet Virtual Private Line

The rates and charges for Ethernet Virtual Private Line (EVPL) service are set forth in Sections 5.7.20 following and are in addition to any applicable rates and charges set forth in any other sections of this service guide. Monthly recurring rates and nonrecurring charges applicable for EVPL service are billed in advance.

(A) Monthly Recurring Charges

Monthly recurring charges are flat recurring rates that apply each month or fraction thereof that a specific rate element is provided regardless of the amount of usage. For billing purposes, each month is considered to have 30 days.

(B) Nonrecurring Charges

Nonrecurring charges are one-time charges that apply for a specific work activity (i.e., installation of service or change to an existing service) and are developed at full cost recovery on a labor hours per labor time basis. In addition, an EVPL Reconfiguration charge, as set forth in 5.7.20 following, will apply for each Ethernet Virtual Connection (EVC), Operator Virtual Connection (OVC), or Quality of Service (QoS) established initially or when the customer requests the EVC, OVC or QoS be reconfigured after the initial set up. The EVPL Reconfiguration charge is in addition to all applicable charges associated with the new configuration. The EVPL Reconfiguration charge will not apply to customers who purchase EVPL under the 7 year Fixed Rate Term Plan (FRTP).

Special construction charges, as set forth in Brightspeed Operating Companies Tariff F.C.C. No. 5, may apply when technical limitations and/or lack of facilities exist, or if it is necessary to construct facilities to satisfy service requests.

(C) Term Discount Plan

The Service Element Term Plan is a Term Discount Plan (TDP) available for EVPL service and applies to UNI and NNI port connections, EVC/OVC connections, QoS and ICO NNI Trunking Arrangement. A TDP provides the customer discounted rates for the rate elements listed.

The customer has the option of ordering EVPL under a term commitment period of 1, 2, 3 or 5 years. The customer must notify the Company in writing the length of its selected term commitment period. In order for a circuit to be eligible for TDP pricing, the customer must commit a UNI and/or NNI port connection to a TDP. All committed ports must be ordered for the same term commitment period (i.e., all 3 years or all 5 years) and remain in-service at the same bandwidth capacity throughout the entire term commitment period. UNI or NNI port connections installed after the establishment of the customer's TDP may be ordered on a month-to-month basis or added as additional committed ports to a customer's existing term commitment period as described in (1) following.

## FACILITIES FOR INTERSTATE ACCESS

5. Special Access Service (Cont'd)5.6 Rate Regulations (Cont'd)5.6.20 Ethernet Virtual Private Line (Cont'd)(C) Term Discount Plan (Cont'd)

The monthly rates for EVPL service under a TDP are set forth in 5.7.20 following.

Although the customer commits the UNI and NNI port connections to the TDP, the following rate elements will receive TDP rates:

UNI Port Connection  
NNI Port Connection  
EVC/OVC Connections  
ICO NNI Trunking Arrangement  
QoS

Since there is no bandwidth or minimum commitment levels required for the UNI or NNI port connections under the TDP, disconnection of or change in the number or bandwidth capacities for these elements do not affect the customer's TDP.

Except as specified in (1) through (3) following, termination liability charges will apply when the customer fails to satisfy the term commitment period or the in-service requirements for their committed port connections.

Rate increases or decreases will automatically be applied to the monthly recurring rates for the remaining term of the TDP. If a Company initiated rate increase causes a customer's rate to increase by 10% or more at any one time, the customer may cancel their TDP without incurring termination liability charges.

At the end of the term commitment period, the customer may subscribe to a new TDP commitment period or month-to-month rates. If the customer does not notify the Company in writing within 60 calendar days prior to the expiration of their 1, 2, 3 or 5 year term commitment period, the term commitment period and TDP rates and conditions in effect at the time of expiration will automatically renew.

## FACILITIES FOR INTERSTATE ACCESS

5. Special Access Service (Cont'd)5.6 Rate Regulations (Cont'd)5.6.20 Ethernet Virtual Private Line (Cont'd)(C) Term Discount Plan (Cont'd)(1) Addition of UNI/NNI Port Connection

When the customer requests the addition of a port connection, the customer will choose one of the following options when ordering a new port connection during its existing term commitment period:

- (a) Add the new port connection to its existing TDP, provided the customer commits to retain the newly installed port connection in-service at the same bandwidth capacity for the remainder of the existing term commitment period. The term commitment period of the customer's existing TDP will continue uninterrupted.
- (b) Convert the existing TDP in its entirety with a new TDP as described in (3) following.

(2) Upgrading a Committed UNI/NNI Port Connection

- (a) A TDP customer may upgrade a committed port connection without incurring termination liability charges, as set forth in (4) following, provided:
  - (1) the bandwidth capacity of the upgraded committed port connection is greater than the bandwidth capacity of the original committed port connection;
  - (2) the customer commits to retain the upgraded committed port connections in-service for the remainder of the existing term commitment period; and
  - (3) the customer purchased the original port connection to offer to third party end users and the end user is the same for both the original committed port connections and the upgraded committed port connection. In the case of a move to a different building, the end user must be the same at the old and the new location.

## FACILITIES FOR INTERSTATE ACCESS

5. Special Access Service (Cont'd)5.6 Rate Regulations (Cont'd)5.6.20 Ethernet Virtual Private Line (Cont'd)(C) Term Discount Plan (Cont'd)(3) Converting a TDP

- (a) The customer may also convert an existing TDP with the Fixed Rate Term Plan (FRTP) described in (D) following without incurring termination liability charges provided the bandwidth capacity of the committed FRTP port connections meets the minimum bandwidth capacity requirement of the FRTP.

(4) Termination Liability

Except as provided for in (2) and (3) preceding, termination liability charges will apply as follows:

- (a) the customer disconnects a committed TDP port connection prior to the end of the term commitment period;
- (b) the customer discontinues an existing TDP in its entirety prior to the end of the term commitment period; or
- (c) the customer converts an existing TDP with a new TDP that does not satisfy the requirements specified in (3) preceding.

## FACILITIES FOR INTERSTATE ACCESS

5. Special Access Service (Cont'd)5.6 Rate Regulations (Cont'd)5.6.20 Ethernet Virtual Private Line (Cont'd)(C) Term Discount Plan (Cont'd)(4) Termination Liability (Cont'd)

The termination liability charge will be equal to 50% of the total monthly recurring rates for each committed TDP port connection included in the customer's TDP for each month remaining in the term commitment period.

The following examples illustrate how the Company will calculate the applicable termination liability charges.

Example 1

A customer discontinues its existing TDP in its entirety in the 20th month of a 3 year term commitment period. The customer included three 100 Mbps committed port connections when they established their initial term plan commitment.

Using an illustrative monthly rate of \$300.00 for the 100 Mbps committed port connection, the Company would bill the customer termination liability charges totaling \$7,200.00 (i.e., \$300.00 x 50% x 3 port connections x 16 months remaining in the term commitment period).

Example 2

A customer discontinues one of the four 30 Mbps committed port connections included in their TDP in the 39th month of a 5 year term commitment period. The customer included all four of these port connections when they established their initial TDP.

Using an illustrative monthly rate of \$100.00 for a 30 Mbps committed port connection, the Company would bill the customer termination liability charges totaling \$1,050.00 for the disconnection of the one port connection (i.e., \$100.00 x 50% x 21 months remaining in the term commitment period).

## FACILITIES FOR INTERSTATE ACCESS

5. Special Access Service (Cont'd)5.6 Rate Regulations (Cont'd)5.6.20 Ethernet Virtual Private Line (Cont'd)(C) Term Discount Plan (Cont'd)(5) Termination Liability - Downgrades

The customer may subsequently decrease existing speed or capacity for EVPL port connections, QoS and EVC/OVC (i.e., 100 Mbps to 50 Mbps; 1 Gbps to 100 Mbps) as low as the previously configured speed without being assessed termination liability. If the customer chooses to decrease the existing speed or capacity to a lower bandwidth than what was on the previous order prior to the expiration date of the fixed period service rate plan termination liability will apply. However, if the customer commits to a new term discount plan and if the total monthly recurring revenue of the new service is equal to or greater than 115% of the remaining value of the existing term plan, no termination liability will apply.

The customer must note on the order that the speed or capacity is being downgraded.

The new service due date must be within 30 days of the due date of the disconnection of the old service, unless the installation is delayed due to Company reasons;

New minimum service period applies to the new service,

The customer agrees to pay all outstanding recurring and nonrecurring charges (these charges will not be included in the new service pricing plan); and

Applicable nonrecurring charges apply and are the charges in effect at the time the service is changed.

Example: 5 year Term Plan: Previous Order: 1000Mb UNI Port @ \$800.00 + 50Mb EVC/OVC @ \$530/ea + Gold 50MB QoS @\$470.00 = \$1,800.00. Total monthly recurring revenue over 5 years is \$108,000.00. Customer decreases from 50Mb EVC/OVC in month 24, to a 20Mb EVC/OVC @ \$420 and decreases to Silver 20MB QoS @ 51.00 along with original 1000MB UNI Port @ \$800.00 = \$1,271.00. The customer must commit the circuit to a new 5 year term for a total monthly recurring revenue over 5 years of \$76,260.00. The remaining value of the previous order (36 months) is \$64,800. The new 5 year commitment is greater than the required 115% of the remaining value (\$64,800) of the existing term plan, so no termination liability applies.

## FACILITIES FOR INTERSTATE ACCESS

5. Special Access Service (Cont'd)5.6 Rate Regulations (Cont'd)5.6.20 Ethernet Virtual Private Line (Cont'd)(D) Fixed Rate Term Plans

The following Fixed Rate Term Plans (FRTPs) are available for EVPL service. These plans are described in detail in 5.6.20 (D) (5), (6), (7) and (8):

Service Element Term Plan – 7 Year Term  
Bandwidth Profile Plan – Monthly and 12, 24, 35 and 60 Month Term  
High Volume Based Plan– 7 Year Term  
Low Volume Based Plan– 7 Year Term

The Service Element Term Plan is available for customers who generally have only one EVC/OVC. The Bandwidth Profile Plan is available for customers who want a pricing advantage to order multiple EVC/OVC's. The High Volume Based Plan is available for customers who purchase a minimum of 1,896 locations during the first calendar year. The Low Volume Based Plan is available for customers who purchase a minimum of 100 locations during the first calendar year.



## FACILITIES FOR INTERSTATE ACCESS

5. Special Access Service (Cont'd)5.6 Rate Regulations (Cont'd)5.6.20 Ethernet Virtual Private Line (Cont'd)(D) Fixed Rate Term Plans (Cont'd)

The customer may move the EVPL circuit and replace it with another EVPL circuit at a different location during the term commitment without early termination liability charges provided (1) the customer agrees to retain the new EVPL circuits at the new location for the remainder of the term period; (2) the relocated EVPL circuit is of equal or greater value to the one being removed; (3) customer submits the orders for the disconnection of the existing EVPL circuit and the installation of the new EVPL circuit at the new location at the same time; and (4) the new EVPL must be ordered under the same term plan as the existing circuit being disconnected.

If the provisions set forth in the previous paragraph are not met, then termination liability charges, set forth in (3) following, will apply for the customer's failure to satisfy the term commitment period requirement for their committed port connections.

Nonrecurring charges will not apply to EVPL arrangements installed under the High Volume and Low Volume Based Plans. Monthly rates for the entire term commitment period of the FRTP will not be increased by the Company for the term commitment period for each EVPL arrangement.

At the end of the term commitment period, the customer may subscribe to a new EVPL commitment period or to month-to-month rates. If the customer does not notify the Company in writing within 60 calendar days prior to the expiration of their term commitment period, the commitment period, rates and conditions in effect at the time of expiration will automatically renew.

## FACILITIES FOR INTERSTATE ACCESS

5. Special Access Service (Cont'd)5.6 Rate Regulations (Cont'd)5.6.20 Ethernet Virtual Private Line (Cont'd)(D) Fixed Rate Term Plans (Cont'd)(1) Upgrades

Customers who subscribe to an EVPL Term Discount Plan (TDP) in (C) preceding may upgrade those services to an EVPL Fixed Rate Term Plan (FRTP) without incurring termination liability charges. The time in service under the EVPL TDP will count toward the minimum term commitment period of the FRTP.

Customers may upgrade existing speed or capacity for EVPL port connections, QoS and EVC (i.e., 50 Mbps to 100 Mbps; 100 Mbps to 1 Gbps) without incurring termination liability charges and time in service under the existing EVPL service will count toward the term commitment period for the new EVPL arrangement.

(2) Downgrades

The customer may subsequently decrease existing speed or capacity for EVPL port connections, QoS and EVC/OVC (i.e., 100 Mbps to 50 Mbps; 1 Gbps to 100 Mbps) as low as the previously configured speed without being assessed termination liability. If the customer chooses to decrease the existing speed or capacity to a lower bandwidth than what was on the previous order prior to the expiration date of the fixed period service rate plan termination liability will apply. However, if the total monthly recurring revenue of the new service is equal to or greater than 115% of the remaining value of the existing term plan, no termination liability will apply.

## FACILITIES FOR INTERSTATE ACCESS

5. Special Access Service (Cont'd)5.6 Rate Regulations (Cont'd)5.6.20 Ethernet Virtual Private Line (Cont'd)(D) Fixed Rate Term Plans (Cont'd)(2) Downgrades (Cont'd)

The customer must note on the order that the speed or capacity is being downgraded.

The new service due date must be within 30 days of the due date of the disconnection of the old service, unless the installation is delayed due to Company reasons; and

New minimum service period applies to the new service; and

The customer agrees to pay all outstanding recurring and nonrecurring charges (these charges will not be included in the new service pricing plan); and

Applicable nonrecurring charges apply and are the charges in effect at the time the service is changed.

Example: 7 year High Volume Based Plan: Previous Order: 1000Mb UNI Port @ \$3,726.00 + 4 – 100Mb EVCs @ \$25/ea = \$3,826.00. Total monthly recurring revenue over 7 years is \$321,384.00. Customer decreases from 1000Mb port in month 24, to a 700Mb UNI Port @ \$3,145 + 4 – 100Mb EVCs @ \$25/ea = \$3,245.00. The customer must commit the circuit to a new 7 year term for a total monthly recurring revenue over 7 years of \$272,580. The remaining value of the previous order (60 months) is \$229,560. The new 7 year commitment is greater than the required 115% of the remaining value (\$229,560) of the existing term plan, so no termination liability applies.

## FACILITIES FOR INTERSTATE ACCESS

5. Special Access Service (Cont'd)5.6 Rate Regulations (Cont'd)5.6.20 Ethernet Virtual Private Line (Cont'd)(D) Fixed Rate Term Plans (Cont'd)(3) Termination Liability

Except where termination liability is waived as set forth in this section, if during the term of the Fixed Rate Term Plan (FRTTP) the customer disconnects an EVPL arrangement prior to the expiration of the 7 year minimum commitment period, termination liability charges will apply as follows:

- (a) an amount equal to 100% of monthly recurring charges for each EVPL arrangement disconnected for the months remaining for year 1 of the 7 year term commitment period of the FRTTP, if any, plus
- (b) an amount equal to 50% of monthly recurring charges for each EVPL arrangement disconnected for the months remaining in year 2 through year 5 of the 7 year term commitment period of the FRTTP, if any, plus
- (c) an amount equal to 20% of monthly recurring charges for each EVPL arrangement disconnected for the months remaining in year 6 through year 7 of the 7 year term commitment period of the FRTTP.

The following example illustrates how the Company will calculate the applicable termination liability charges.

Example:

A customer discontinues an EVPL arrangement committed to the 7 year FRTTP in month 20 of the 7 year minimum term commitment period. Using an illustrative monthly recurring rate of \$1800.00 for the EVPL arrangement, the Company would bill the customer termination liability charges totaling \$44,640.00.

$$\$1800.00 @ 50\% = \$900.00 \times 40 \text{ months} = \$36,000.00$$

$$\$1800.00 @ 20\% = \$360.00 \times 24 \text{ months} = \$8,640.00$$

$$\$36,000.00 + \$8,640.00 = \$44,640.00$$

## FACILITIES FOR INTERSTATE ACCESS

5. Special Access Service (Cont'd)5.6 Rate Regulations (Cont'd)5.6.20 Ethernet Virtual Private Line (Cont'd)(D) Fixed Rate Term Plans (Cont'd)(3) Termination Liability

Should the customer choose to discontinue fixed period service prior to completion of the minimum service period of the Bandwidth Profile, termination charges will apply. The termination charge is 100% of the minimum billing level for the remaining months of the minimum service period, plus 40% for EVPL, of the remaining portion of the fixed period service. Should the customer choose to discontinue fixed period service after the completion of the minimum service period, termination charges equal to 40% for EVPL, of the minimum billing level for the remaining portion of the fixed period service will apply. For example, if an EVPL customer discontinues a service after completing 17 months of a 36-month term, the termination charge will be the minimum billing level for the service, multiplied by 40%, multiplied by 19 months.

## FACILITIES FOR INTERSTATE ACCESS

5. Special Access Service (Cont'd)5.6 Rate Regulations (Cont'd)5.6.20 Ethernet Virtual Private Line (Cont'd)(D) Fixed Rate Term Plans (Cont'd)(4) Chronic Interruption

For purposes of the Fixed Rate Term Plan (F RTP), a Chronic Interruption is defined as (1) an interruption in service due to a failure on the core portion of the EVPL network on four (4) or more separate occasions of five (5) minutes or more each, or twenty-four (24) hours or more in the aggregate, in any calendar month; or (2) both EVC/OVCs do not meet network latency, jitter or packet delivery performance standards provided in 5.6.20(E)(2) following in any three (3) separate months during any period of six (6) consecutive months.

When a customer orders EVPL under a F RTP and a Chronic Interruption occurs with respect to EVPL, the Company will provide to the customer, within ten (10) calendar days of the last interruption or within a month after any failure to meet the network latency, jitter or packet delivery performance standards, a detailed report with respect to such interruptions on the EVPL service that will include the root causes of such interruptions, remedial actions being taken to prevent similar future interruptions and timelines for the completion of such actions. The Company will provide bi-weekly written updates on the progress of such remedial actions until completed to the reasonable satisfaction of the customer. The timeline for the completion of such remedial actions will not exceed thirty (30) days. If after the completion of such remedial actions an interruption or performance failure occurs on the same EVPL service, or the Company fails to complete such remedial action within such thirty (30) day period, the customer may terminate the affected EVPL service without incurring early termination liability charges, upon providing written notice of such termination to the Company within twelve (12) months of the date of the last interruption or failure to meet the network latency, jitter or packet delivery performance standards triggering a Chronic Interruption.

## FACILITIES FOR INTERSTATE ACCESS

5. Special Access Service (Cont'd)5.6 Rate Regulations (Cont'd)5.6.20 Ethernet Virtual Private Line (Cont'd)(D) Fixed Rate Term Plans (Cont'd)(5) Service Element Term Plan

An Ethernet Virtual Private Line Service Element Term Plan is available for EVPL service and applies to UNI and NNI port connections, EVC/OVC connections and QoS. This plan provides the customer discounted rates for the rate elements listed below.

The customer orders the EVPL Service Element Term Plan under a term commitment period of 7 years. In order for a circuit to be eligible for Service Element Term Plan pricing, the customer must commit a UNI and/or NNI port connection to the Service Element Term Plan. All EVPL circuits ordered under the Service Element Term Plan will begin in month one.

The monthly rates for EVPL service under a Service Element Term Plan are set forth in 5.7.20 following.

Although the customer commits the UNI and NNI port connections to the Service Element Term Plan, the following rate elements will receive Service Element Term Plan rates:

UNI Port Connection  
NNI Port Connection  
External NNI Port Connection  
EVC/OVC Connection  
QoS  
ICO NNI Trunking Arrangement

## FACILITIES FOR INTERSTATE ACCESS

5. Special Access Service (Cont'd)5.6 Ethernet Virtual Private Line (Cont'd)5.6.20 Rate Regulations (Cont'd)(D) Fixed Rate Term Plans (Cont'd)(6) Bandwidth Profile Plan (BWP)

The Bandwidth Profile is the standard EVPL offering which uses the native Ethernet protocol to connect multiple enterprise locations with the customer's premises.

A monthly rate is assessed per Bandwidth Profile (BWP) subscribed to and the term plan chosen (12, 24, 36 and 60 month) as set forth in 5.7.21 (B) , following. Customers may subscribe to the following:

- a. Customer Premises Network Interface (NI) - The Company network interface is the point of interconnection between Company communications facilities and terminal equipment or other customer-provided facilities. The network interface is the point of demarcation on the customer's premises where the Company's responsibility for the provision of EVPL Service ends.
- b. EVPL Port - A nonrecurring charge applies per new EVPL Port. A nonrecurring charge for an EVPL Port will also be assessed when an electrical port is changing to an optical port or an optical port is changing to an electrical port. Exception: there will be no charge if a customer goes from one electrical port to another electrical port or from one optical port to another optical port. Customers may choose to connect to an electrical 10/100 port or an electrical or optical 1,000 Mbps or 10,000 Mbps port on the Company network.

The following options are available:

- 10 Mbps Ports: 3 Mbps, 5 Mbps, 7 Mbps and 10 Mbps
- 100 Mbps Ports: 3 Mbps, 5 Mbps, 7 Mbps, 10 Mbps, 20 Mbps, 30 Mbps, 40 Mbps, 50 Mbps, 60 Mbps, 70 Mbps, 80 Mbps, 90 Mbps and 100 Mbps
- 1,000 Mbps Ports: 10 Mbps, 20 Mbps, 30 Mbps, 40 Mbps, 50 Mbps, 60 Mbps, 70 Mbps, 80 Mbps, 90 Mbps, 100 Mbps, 200 Mbps, 300 Mbps, 400 Mbps, 500 Mbps, 600 Mbps, 700 Mbps, 800 Mbps, 900 Mbps and 1,000 Mbps (1 Gbps)
- 10,000 Mbps Ports: 2 Gbps, 3 Gbps, 4 Gbps, 5 Gbps, 6 Gbps, 7 Gbps, 8 Gbps, 9 Gbps and 10 Gbps (Available where facilities exist)



## FACILITIES FOR INTERSTATE ACCESS

5. Special Access Service (Cont'd)5.6 Ethernet Virtual Private Line (Cont'd)5.6.20 Rate Regulations (Cont'd)(D) Fixed Rate Term Plans (Cont'd)(6) Bandwidth Profile Plan (BWP) (Cont'd)

c. Network to Network (NNI) Port Connection - The Network to Network (NNI) Port Connection is the interface between distinct CENs operated by one or more customers. The NNI Port Connection is available at operating speeds of 1000 Mbps (1 Gbps) and 10000 Mbps (10 Gbps).

d. Ethernet Virtual Connections (EVCs) or Operator Virtual Connections (OVCs) - Each EVPL Port provided by the Company will come standard with the capability to provide an Ethernet Virtual Connection (EVC) or Operator Virtual Connection (OVC). An EVC is associated with a UNI port type, an OVC is associated with an ENNI port type. Customers may order more than one EVC or OVC per port. The Company will bill a monthly EVC or OVC charge per port that the EVC or OVC terminates on, at rates set forth in 7.15.4.A.2.c., following.

e. Quality of Service (QoS) - Quality of Service (QoS) allows customers to prioritize their traffic managed through the Company's EVPL Service. Rates are set forth in 7.15.3, following

## FACILITIES FOR INTERSTATE ACCESS

5. Special Access Service (Cont'd)5.6 Ethernet Virtual Private Line (Cont'd)5.6.20 Rate Regulations (Cont'd)(D) Fixed Rate Term Plans (Cont'd)(7) High Volume Based Plan

The High Volume Based Plan is available for EVPL service and requires the customer to purchase a minimum of 1,896 locations of EVPL service from the Brightspeed Local Operating Companies during the first calendar year they participate in the plan. The High Volume Based Plan includes the UNI Bandwidth Port, NNI Port and Gold QoS Service. EVC's are a separate rate and are offered on a 7 year term. The rates in effect when a circuit is installed are the rates that apply for the entire 7 year term, rate changes that occur after the installation of a circuit do not apply to existing circuits. The rates apply only to the customer locations specified in this service guide. The High Volume Based Plan provides the customer discounted rates for the rate elements listed below.

The customer orders the EVPL High Volume Based Plan under a term commitment period of 7 years. In order for a circuit to be eligible for High Volume Based Plan pricing, the customer must commit the UNI Bandwidth Port and NNI Port to the plan. All EVPL circuits ordered under the High Volume Based Plan will begin in month one.

The monthly rates for EVPL service under the High Volume Based Plan are set forth in 5.7.21 following.

Although the customer commits the UNI Bandwidth Port and NNI Port to the High Volume Based Plan, the following rate elements will receive the High Volume Based Plan rates:

- UNI Bandwidth Port (includes Gold QoS)
- NNI Port (no charge)
- EVC Connection
- OAM EVC
- ICO NNI Trunking Arrangement

## FACILITIES FOR INTERSTATE ACCESS

5. Special Access Service (Cont'd)5.6 Ethernet Virtual Private Line (Cont'd)5.6.20 Rate Regulations (Cont'd)(D) Fixed Rate Term Plans (Cont'd)(8) Low Volume Based Plan

The Low Volume Based Plan is available for EVPL service and requires the customer to purchase a minimum of 100 locations of EVPL service from the Brightspeed Local Operating Companies during the first calendar year they participate in the plan. Special construction charges may apply. The Low Volume Based Plan includes the UNI Bandwidth Port, NNI Port and Gold QoS Service. EVC's are a separate rate and are offered on a 7 year term. The rates in effect when a circuit is installed are the rates that apply for the entire 7 year term, rate changes that occur after the installation of a circuit do not apply to existing circuits. The rates apply only to the customer locations specified in this service guide. The Low Volume Based Plan provides the customer discounted rates for the rate elements listed below.

The customer orders the EVPL Low Volume Based Plan under a term commitment period of 7 years. In order for a circuit to be eligible for Low Volume Based Plan pricing, the customer must commit the UNI Bandwidth Port and NNI Port to the plan. All EVPL circuits ordered under the Low Volume Based Plan will begin in month one.

The monthly rates for EVPL service under the Low Volume Based Plan are set forth in 5.7.21 following.

Although the customer commits the UNI Bandwidth Port and NNI Port to the Low Volume Based Plan, the following rate elements will receive the Low Volume Based Plan rates:

UNI Bandwidth Port (includes Gold QoS)  
NNI Port  
EVC Connection  
ICO NNI Trunking Arrangement

## FACILITIES FOR INTERSTATE ACCESS

5. Special Access Service (Cont'd)5.6 Rate Regulations (Cont'd)5.6.20 Ethernet Virtual Private Line (Cont'd)(E) Service Level Agreement

Service Level Agreements (SLAs) will be applied on a per Quality of Service (QoS) basis for Ethernet Virtual Connections (EVCs); traffic representing the different QoS (i.e., Gold, Silver or Best Effort) transported across the same EVC (measured between two NIDs) will have different SLAs. Details of the technical measurements and performance results methodologies for each commitment are provided in the Technical Publications set forth in 5.2.12(B) preceding.

In accordance with 5.6.20(E)(4) following, credits are available for missed commitments to customers who purchase EVPL. Credits only apply for portions of the service provided by the Company.

- Repair Commitment

The Repair Commitment is measured on a per occurrence basis for each EVC for all QoS. A Fault Report is produced through the Company reporting system that aids identification of potential outage durations upon which credits may be provided.

- Network Service Level Commitments

The Network Service Level Commitments are measured on the monthly performance of the EVPL network during a specific calendar month by QoS. A SLA report is produced through the Company reporting system that provides details of missed Network Service Level Commitments by QoS upon which credits may be provided upon a specific calendar month's performance results.

The Company's performance measurement data for the Repair Commitment and Network Service Level Commitments will be collected and calculated utilizing the Company's internal processes. The Company's calculation of its performance will be consistent with the Company's obligations to provide a credit for a missed performance commitment set forth following for SLA credits.

## FACILITIES FOR INTERSTATE ACCESS

5. Special Access Service (Cont'd)5.6 Rate Regulations (Cont'd)5.6.20 Ethernet Virtual Private Line (Cont'd)(E) Service Level Agreement (Cont'd)(1) SLA DefinitionsTime to Repair

Time to Repair measures the duration of the interruption on the customer's EVPL for all QoS. This measurement will require the customer to report the problem to the Company. For EVPL, an interruption is defined as a condition that renders an EVPL circuit completely unavailable for use by the customer (i.e., the network is incapable of accepting and delivering customer data).

The repair interval will start with the time the trouble ticket is created and end when the fault is remediated. The SLA measurement will be based on each individual trouble ticket for a customer's connection. Time for scheduled maintenance windows as set forth in 5.2.12(A) preceding does not count towards SLA threshold.

The SLA will be calculated for each individual interruption. An example of the calculation is displayed below:

Example: Based on 15 hours of interruption

Total MRC of \$1,200.00 \* 3/30 = Credit amount of \$120.00

## FACILITIES FOR INTERSTATE ACCESS

5. Special Access Service (Cont'd)5.6 Rate Regulations (Cont'd)5.6.20 Ethernet Virtual Private Line (Cont'd)(E) Service Level Agreement (Cont'd)(1) SLA Definitions (Cont'd)Network Availability

Network Availability measures the percentages of time by QoS during a calendar month that the customer's service is available.

The SLA will be calculated by QoS by taking the total number of minutes in a day times the number of calendar days in a month, minus the number of minutes of interruption during the month divided by the number of minutes in a day times the number of calendar days in the month. The Company will not round up to the next nearest percent in order to meet the Network Availability service level commitment of 99.995%. Excluded from the outage time and service time are scheduled maintenance windows, set forth in 5.2.12(A) preceding, and the time the network was unavailable due to circumstances outside of Company's control, as set forth in 5.6.20(E)(3) following. An example of the calculation is displayed below:

Example:  $1440 * 30 = 43200$ ;  $43200 - 1200 = 42000$ ,  
 $42000 / 43200 = 97.222\%$

Total MRC of \$1,200.00 \* 3/30 = Credit amount of \$120.00

## FACILITIES FOR INTERSTATE ACCESS

5. Special Access Service (Cont'd)5.6 Rate Regulations (Cont'd)5.6.20 Ethernet Virtual Private Line (Cont'd)(E) Service Level Agreement (Cont'd)(1) SLA Definitions (Cont'd)Network Latency

Network Latency measures average two-way delay (including link insertion delays, propagation delays and queuing delays in the network) in milliseconds within the EVPL access service area.

This SLA will be calculated for each QoS, except for Best Effort, by averaging the measured latency of "in-band" test frames for each eligible QoS within the EVPL network (i.e., between each pair of connections on a NID to NID basis) during a calendar month. An example of the calculation is displayed below:

Example: Monthly average was 12 ms (round-trip).

Total MRC of \$1,200 \* 3/30 = Credit amount of \$120.00

Jitter

Jitter measures the variance in frame delay (in milliseconds) between two performance test frames as measured at the ingress and egress NIDs for Gold and Silver QoS.

This SLA will be calculated for the Gold and Silver QoS by averaging the measured jitter of "in-band" test frames for each of the customer's eligible QoS queue within the EVPL (i.e., between each pair of connections) during a calendar month. An example of the calculation is displayed below:

Example: Monthly average was 5 ms.

Total MRC of \$1,200 \* 3/30 = Credit amount of \$120.00

## FACILITIES FOR INTERSTATE ACCESS

5. Special Access Service (Cont'd)5.6 Rate Regulations (Cont'd)5.6.20 Ethernet Virtual Private Line (Cont'd)(E) Service Level Agreement (Cont'd)(1) SLA Definitions (Cont'd)Packet Delivery

Packet Delivery measures the percentage of packets conforming to the committed EVC bandwidth successfully delivered across the network (i.e. NID to NID) without being dropped or lost.

This SLA will be calculated for each QoS, except for Best Effort, by averaging the measured packet delivery of "in-band" test frames for eligible QoS within the EVPL network (i.e., between each pair of connections) during a calendar month. An example of the calculation is displayed below:

Example: Monthly average was 98%

Total MRC of \$1,200 \* 3/30 = Credit amount of \$120.00

## (2) The Company's Service Level Commitments for EVPL are as follows:

Time to Repair

- Best Effort QoS – Not applicable
- Silver QoS – 4 hours or less
- Gold QoS – 4 hours or less



## FACILITIES FOR INTERSTATE ACCESS

5. Special Access Service (Cont'd)5.6 Rate Regulations (Cont'd)5.6.20 Ethernet Virtual Private Line (Cont'd)(E) Service Level Agreement (Cont'd)

## (2) (Cont'd)

Network Availability

- Best Effort QoS – Not Applicable
- Silver QoS – 99.95% or greater
- Gold QoS – 99.995% or greater

Latency (two-way)

- Best Effort QoS – Not Applicable
- Silver QoS – 20 milliseconds or less
- Gold QoS:
  - 10 ms or less (routes up to 225 one-way air miles)
  - 12 ms or less (routes of 225 to 315 one-way air miles)
  - 14 ms or less (routes of 316 to 405 one-way air miles)
  - Increase by 2 ms for every 90 one-way air miles exceeding 405 miles.

Jitter

- Best Effort QoS – Not Applicable
- Silver QoS – 4 milliseconds
- Gold QoS – 1 millisecond or less

Packet Delivery

- Best Effort QoS – Not Applicable
- Silver QoS – 99.95% or greater
- Gold QoS – 99.995% or greater

## FACILITIES FOR INTERSTATE ACCESS

5. Special Access Service (Cont'd)5.6 Rate Regulations (Cont'd)5.6.20 Ethernet Virtual Private Line (Cont'd)(E) Service Level Agreement (Cont'd)(3) SLA Obligations

The Company SLAs are defined in (1) and (2) preceding and are in addition to the following:

- A customer must subscribe to the Gold or Silver QoS that is provided with reporting to receive credits for missed service level commitments; and
- Credits are not provided for a partial month service; and
- A customer's account must be current to receive a credit.

(a) When an SLA Credit Does Not Apply

SLA credits do not apply when any stated objective is not met because the Company does not have control over the circumstances causing the objective to be missed or when the missed objective is not caused by the Company's negligence or fault. Situations over which the Company does not have control, include, but are not limited to, the following:

- any negligence or willful misconduct on the part of the customer, its agents or contractors;

## FACILITIES FOR INTERSTATE ACCESS

5. Special Access Service (Cont'd)5.6 Rate Regulations (Cont'd)5.6.20 Ethernet Virtual Private Line (Cont'd)(E) Service Level Agreement (Cont'd)(3) SLA Obligations (Cont'd)

## (a) (Cont'd)

- labor difficulties, governmental orders, civil commotions, acts of civil or military authority, embargoes, epidemics, declared National Emergencies, criminal actions against the Company, war, terrorist acts, riots, insurrections, fires, explosions, nuclear accidents, power blackouts, acts of God (including, but not limited to, earthquakes, floods or unusually severe weather) or other circumstances beyond the Company's control;
- when it is necessary for the Company to perform preventive maintenance and software upgrades and the EVPL service will be unavailable during the period of time when the preventive maintenance is being performed;
- the customer's premises equipment, including customer owned power and environmental conditions, located on the customer's premises; and
- unavailability of the customer's facilities caused by the customer or any third party.

## FACILITIES FOR INTERSTATE ACCESS

5. Special Access Service (Cont'd)5.6 Rate Regulations (Cont'd)5.6.20 Ethernet Virtual Private Line (Cont'd)(E) Service Level Agreement (Cont'd)(3) SLA Obligations (Cont'd)(b) When an SLA Credit Applies

When the Company has not provided a SLA credit, the customer may request a SLA credit. A customer request for a Network Service Level SLA credit must be submitted on a standard request form issued by the Company that includes the month the SLA commitment was missed, accurate identifications of the affected circuit and the observed measurement of the specific SLA that was missed. A customer request for a Repair SLA credit must be submitted on a standard request form issued by the Company that includes the month the SLA commitment was missed, accurate identification of the affected circuit and the trouble ticket number of the repair request.

The Company will investigate customer requests for any SLA credits to determine the cause of any performance failures reported by the customer. The Company will investigate the customer's request over a period of up to 45 calendar days. The 45-day period will begin when the customer makes the request for credit with the Company representative.

## FACILITIES FOR INTERSTATE ACCESS

5. Special Access Service (Cont'd)5.6 Rate Regulations (Cont'd)5.6.20 Ethernet Virtual Private Line (Cont'd)(E) Service Level Agreement (Cont'd)(4) SLA Credits for Ethernet Virtual Connections (EVCs) with Reporting

The following credits will apply when the Company misses a SLA on any single QoS as described following. A maximum of one credit for each SLA will be applied monthly per EVC for a SLA not met for any QoS that is supported by the customer's QoS profile.

Time to Repair:

- 0 to 4 hours per incident: no credit.
- Over 4 hours to 24 hours per incident: a credit equal to 3/30 of the monthly recurring charges for all the rate elements associated with the affected EVC.
- Each additional 24-hour period, per incident: credit an additional amount equal to 3/30 of the monthly recurring charges for all the rate elements associated with the affected EVPL service.

Network Availability: a credit equal to 3/30 of the monthly recurring charges for all the rate elements associated with the affected EVPL service.

Network Latency: a credit equal to 3/30 of the monthly recurring charges for all rate elements associated with the affected EVPL service.

## FACILITIES FOR INTERSTATE ACCESS

5. Special Access Service (Cont'd)5.6 Rate Regulations (Cont'd)5.6.20 Ethernet Virtual Private Line (Cont'd)(E) Service Level Agreement (Cont'd)(4) SLA Credits for Ethernet Virtual Connections (EVCs) with Reporting (Cont'd)

Jitter: a credit equal to 3/30 of the monthly recurring charges for all the rate elements associated with the affected EVPL service.

Packet Delivery: a credit equal to 3/30 of the monthly recurring charges for all rate elements associated with the affected EVPL service.

The SLA credit amount will be determined by applying the credits outlined above to the rate elements or total billed revenues specified following.

The total credits issued for all SLAs for a specific EVC during a single bill period may not exceed the total monthly recurring charges billed for all the rate elements associated with that EVPL service. Credits are not provided for partial month service.

- (a) Time to Repair Credit – The service level commitment measurement will be based on each individual trouble ticket for a customer's connection. Multiple trouble tickets on the same day for the same customer connection will only be eligible for one time to repair credit. The SLA credit will apply to the monthly recurring charges for all the rate elements associated with the affected EVPL service.

## FACILITIES FOR INTERSTATE ACCESS

5. Special Access Service (Cont'd)5.6 Rate Regulations (Cont'd)5.6.20 Ethernet Virtual Private Line (Cont'd)(E) Service Level Agreement (Cont'd)(4) SLA Credits for Ethernet Virtual Connections (EVCs) with Reporting (Cont'd)

- (b) Network Availability Credit – The service level commitment measurement will be based on a specific calendar month's performance. The credit will apply for each EVC that does not meet the availability commitment. The SLA credit will apply to the monthly recurring charges for all the rate elements associated with the affected EVPL service.
- (c) Latency Credit – The service level commitment measurement will be based on a specific calendar month's performance. The credit will apply for each EVC that does not meet the latency commitment for any eligible QoS. The SLA credit will apply to the monthly recurring charges for all the rate elements associated with the affected EVPL service.
- (d) Jitter Credit – The service level commitment measurement will be based on a specific calendar month's performance. The credit will apply for each EVC that does not meet the jitter commitment for any eligible QoS. The SLA credit will apply to the monthly recurring charges for all the rate elements associated with the affected EVPL service.
- (e) Packet Delivery Credit – The service level commitment measurement will be based on a specific calendar month's performance. The credit will apply for each EVC that does not meet the packet delivery commitment for any eligible QoS. The SLA credit will apply to the monthly recurring charges for all the rate elements associated with the affected EVPL service.

## FACILITIES FOR INTERSTATE ACCESS

5. Special Access Service (Cont'd)5.6 Rate Regulations (Cont'd)5.6.21 Optical Wavelength Service (OWS)

The rates and charges for OWS service are set forth in the following and are in addition to any applicable rates and charges set forth in any other sections of this service guide. Nonrecurring charges and monthly recurring rates applicable for OWS service are billed in advance.

(A) Monthly Rates

Monthly rates are recurring rates that apply each month or fraction thereof that a Special Access Service is provided. For billing purposes, each month is considered to have 30 days.

(B) Nonrecurring Charges

Nonrecurring charges are one-time charges that apply for specific work activity (i.e., installation or change to an existing service). The types of nonrecurring charges that apply for Special Access Service are: installation of service and service rearrangements.

(1) Installation of Service

Nonrecurring charges apply to each service installed. The nonrecurring charges for the installation of service are set for each channel type as a nonrecurring charge for the Channel Termination.

(2) Service Rearrangements

Service rearrangements are changes to existing (installed) services which may be administrative only in nature, as set forth following, or that involve actual physical change to the service. .



## FACILITIES FOR INTERSTATE ACCESS

5. Special Access Service (Cont'd)5.6 Rate Regulations (Cont'd)5.6.21 Optical Wavelength Service (OWS) (Cont'd)

Changes to pending orders are set forth in 5.4 preceding.

Changes in the physical location of the point of termination or customer designated premises are moves as set forth following.

Changes in the type of Service or Channel Termination which result in a change of the minimum period requirement will be treated as a discontinuance of the service and an installation of a new service.

Changes in ownership or transfer of responsibility from one customer to another will be treated as a discontinuance of the service and an installation of a new service. In the event the change in ownership or transfer of responsibility is as set forth in 2.1.2(A) preceding where there is no change in facilities or arrangements, the change will be treated as an administrative change.

Administrative changes will be made without charge(s) to the customer. Administrative changes are as follows:

- Change of customer name;
- Change of customer or customer's end user premises address when the change of address is not a result of physical relocation of equipment;
- Change in billing data (name, address, or contact name or telephone number);
- Change of agency authorization;
- Change of customer circuit identification;
- Change of billing account number;
- Change of customer test line number;
- Change of customer or customer's end user contact name or telephone number; and
- Change of jurisdiction.

## FACILITIES FOR INTERSTATE ACCESS

5. Special Access Service (Cont'd)5.6 Rate Regulations (Cont'd)5.6.21 Optical Wavelength Service (OWS) (Cont'd)

All other service rearrangements will be charged as follows:

- If the change involves the addition of other customer designated premises to an existing service, the nonrecurring charge for the channel termination rate element will apply. The charge(s) will apply only for the location(s) that is being added.

Moves

Changes in the physical location of the point of termination are treated as moves which are described and charged for as in 5.6.4.

## FACILITIES FOR INTERSTATE ACCESS

5. Special Access Service (Cont'd)5.6 Rate Regulations (Cont'd)5.6.21 Optical Wavelength Service (OWS) (Cont'd)Pricing Plans

OWS service is available on a month-to-month basis or for a period of one, three or five years. All OWS arrangements will begin in month one. If the customer requests that the service be disconnected prior to completion of the minimum service period of 12 months, termination liability charges equal to 100% of the total monthly recurring charges for the remaining months of the minimum service period plus 70% of the total monthly recurring charges for the remaining months of the term. Any termination after the minimum service period of 12 months termination liability charges equal to 70% of the remaining months of the term will apply. For example, a customer disconnecting in the 12th month of a 3 year plan will be charged 70% of the remaining 24 months of billing. The Federal Government and its authorized agents are exempt from the 50% termination liability penalty charge if service is discontinued prior to the expiration of the one, three or five year minimum commitment period.

Additionally, customers may disconnect OWS service, without penalty, should the total monthly recurring rates associated with OWS service increase by 10% or more at any one time. The customer must notify the Company in writing within 90 days after the effective date of the rate increase if they elect to discontinue service. Rate decreases will automatically be applied to the monthly recurring rates for the remainder of the service

If the customer does not specify renewal terms in writing 90 days prior to the expiration of the one, three or five year period, the commitment period and OWS service rates in effect at the time of expiration will automatically renew. Alternatively, 90 days prior to the expiration of the one, three or five year period the customer may specify in writing their intent to continue use of the services under month-to-month rates. The customer can terminate OWS service at the end of the minimum commitment period with no penalty or obligation to continue the service. Further, if the customer notifies the Company in writing 90 days prior to the expiration date of their minimum commitment period with their intent to not renew their OWS service, the customer will have six (6) months after the expiration date to submit their disconnect order(s). If the customer fails to submit their disconnect order(s), by the end of the six (6) month period, the commitment period in effect at the time of the original expiration period will automatically renew at the current service guide rates. If the customer submits their disconnect orders(s) after the six (6) month period, termination liability charges will apply. Termination liability charges will be calculated at 50% of the monthly recurring charges for the remaining months of the commitment period up to a maximum of twelve (12) months. Time from the expiration of the original commitment period until the disconnect order(s) are received will apply for calculation of the termination liability charges.

## FACILITIES FOR INTERSTATE ACCESS

5. Special Access Service (Cont'd)5.6 Rate Regulations (Cont'd)5.6.21 Optical Wavelength Service (OWS) (Cont'd)Upgrades

Customers may upgrade OWS without incurring termination liability charges under the following circumstances:

- (1) The order for the disconnect of the existing OWS and the order for the upgraded OWS must be received at the same time.
- (2) The new OWS is provided between the same customer and central office locations as the discontinued service.
- (3) The service period of the new OWS is equal to or greater than the service period of the existing OWS service.

Termination Liability – Downgrades

If the customer chooses to decrease the existing speed or capacity to a lower bandwidth than what was on the previous order prior to the expiration date of the fixed period service rate plan, termination liability will apply. However, if the customer commits to a new term discount plan and if the total monthly recurring revenue of the new service is equal to or greater than 115% of the remaining value of the existing term plan, no termination liability will apply.

The customer must note on the order that the speed or capacity is being downgraded.

The new service due date must be within 30 days of the due date of the disconnection of the old service, unless the installation is delayed due to Company reasons.

New minimum service period applies to the new service,

The customer agrees to pay all outstanding recurring and nonrecurring charges (these charges will not be included in the new service pricing plan); and

Applicable nonrecurring charges apply and are the charges in effect at the time the service is changed

Service Guarantee Regulations are set forth in Section 2.4.4, preceding.

FACILITIES FOR INTERSTATE ACCESS

5 SPECIAL ACCESS (Cont'd)

5.7 Rates and Charges

5.7.1 Nonrecurring Charges

Special Access Ordering Charges

Design Change  
Per ASR/Per Occurrence

Jurisdiction

Alabama

\$29.70

Missouri

\$29.70

FACILITIES FOR INTERSTATE ACCESS

5 SPECIAL ACCESS (Cont'd)

5.7 Rates and Charges

5.7.2 Voiceband Facilities <sup>[1]</sup>

(A) Standard Arrangements

<u>Jurisdiction</u>	<u>Special Transport</u>	<u>Channel Termination (SAL)</u>		
	<u>(Per Air Line Mile)</u> <u>Monthly Rate</u>	<u>Nonrecurring</u> <u>Charge</u>	<u>Two-Wire</u> <u>Monthly Rate</u>	<u>Four-Wire</u> <u>Monthly Rate</u>
Alabama	\$7.90	\$152.50	\$93.00	\$135.00
Missouri	7.90	200.00	93.00	135.00

<sup>[1]</sup> Effective February 1, 2020 Voiceband Services are grandfathered. Availability to current customers is limited to circuits in service at existing locations.

FACILITIES FOR INTERSTATE ACCESS

5. SPECIAL ACCESS (Cont'd)

5.7 Rates and Charges (Cont'd)

5.7.2 Voiceband Facilities <sup>[1]</sup> (Cont'd)

(B) Optional Arrangements

<u>Jurisdiction</u>	<u>Supplemental Features</u>	
	<u>Multi-point Data Bridging</u> (Per Port) Monthly <u>Rate</u>	<u>Voice Conference Bridging</u> (Per Port) Monthly <u>Rate</u>
Alabama	\$7.92	\$8.00
Missouri	\$7.92	\$8.00

<sup>[1]</sup> Effective February 1, 2020 Voiceband Services are grandfathered. Availability to current customers is limited to circuits in service at existing locations.

FACILITIES FOR INTERSTATE ACCESS

5 SPECIAL ACCESS (Cont'd)

5.7 Rates and Charges (Cont'd)

5.7.2 Voiceband Facilities <sup>[1]</sup> (Cont'd)

(B) Optional Arrangements (Cont'd)

<u>Jurisdiction</u>	<u>Supplemental Features</u>	
	<u>Common Equipment</u>	<u>Per Two-Wire Port</u>
	<u>Monthly Rate</u>	<u>Monthly Rate</u>
Alabama	\$30.00	\$2.00
Missouri	30.00	2.00

<sup>[1]</sup> Effective February 1, 2020 Voiceband Services are grandfathered. Availability to current customers is limited to circuits in service at existing locations.



FACILITIES FOR INTERSTATE ACCESS

5 SPECIAL ACCESS (Cont'd)

5.7 Rates and Charges (Cont'd)

5.7.2 Voiceband Facilities <sup>[1]</sup> (Cont'd)

(B) Optional Arrangements (Cont'd)

<u>Jurisdiction</u>	<u>Supplemental Features</u>	
	<u>Conditioning Arrangements - Data</u>	
	<u>Type C</u>	<u>Type DA</u>
	<u>Monthly</u>	<u>Monthly</u>
	<u>Rate</u>	<u>Rate</u>
Alabama	\$1.53	\$1.98
Missouri	1.53	1.98

[1] Effective February 1, 2020 Voiceband Services are grandfathered. Availability to current customers is limited to circuits in service at existing locations.

FACILITIES FOR INTERSTATE ACCESS

5 SPECIAL ACCESS (Cont'd)

5.7 Rates and Charges (Cont'd)

5.7.2 Voiceband Facilities <sup>[1]</sup> (Cont'd)

(B) Optional Arrangements (Cont'd)

Supplemental Features  
Conditioning Arrangements - Data  
Type C – Improved  
Monthly  
Rate

Jurisdiction

Alabama	\$29.70
Missouri	29.70

[1] Effective February 1, 2020 Voiceband Services are grandfathered. Availability to current customers is limited to circuits in service at existing locations.

FACILITIES FOR INTERSTATE ACCESS

5 SPECIAL ACCESS (Cont'd)

5.7 Rates and Charges (Cont'd)

5.7.2 Voiceband Facilities <sup>[1]</sup> (Cont'd)

(B) Optional Arrangements (Cont'd)

<u>Jurisdiction</u>	<u>Supplemental Features Signaling Arrangement</u>	
	<u>Loop Signaling Range Extension, per SAL Monthly Rate</u>	<u>Loop or E&amp;M to SF, per SAL Monthly Rate</u>
Alabama	\$10.00	\$16.00
Missouri	10.00	16.00

[1] Effective February 1, 2020 Voiceband Services are grandfathered. Availability to current customers is limited to circuits in service at existing locations.

FACILITIES FOR INTERSTATE ACCESS

5 SPECIAL ACCESS (Cont'd)

5.7 Rates and Charges (Cont'd)

5.7.2 Voiceband Facilities <sup>[1]</sup> (Cont'd)

(B) Optional Arrangements (Cont'd)

<u>Jurisdiction</u>	<u>Supplemental Features</u>	
	<u>Signaling Arrangement</u>	
	<u>E&amp;M to DX, per SAL</u>	<u>E&amp;M to Loop, per SAL</u>
	<u>Monthly</u>	<u>Monthly</u>
	<u>Rate</u>	<u>Rate</u>
Alabama	\$14.00	\$12.00
Missouri	14.00	12.00

[1] Effective February 1, 2020 Voiceband Services are grandfathered. Availability to current customers is limited to circuits in service at existing locations.

FACILITIES FOR INTERSTATE ACCESS

5 SPECIAL ACCESS (Cont'd)

5.7 Rates and Charges (Cont'd)

5.7.2 Voiceband Facilities <sup>[1]</sup> (Cont'd)

(B) Optional Arrangements (Cont'd)

<u>Jurisdiction</u>	<u>Supplemental Features</u>	
	<u>Loop or E&amp;M to PCM, per SAL</u>	<u>Automatic Ringdown, per SAL</u>
	<u>Monthly</u>	<u>Monthly</u>
	<u>Rate</u>	<u>Rate</u>
Alabama	\$3.98	\$10.00
Missouri	3.98	10.00

[1] Effective February 1, 2020 Voiceband Services are grandfathered. Availability to current customers is limited to circuits in service at existing locations.

FACILITIES FOR INTERSTATE ACCESS

5 SPECIAL ACCESS (Cont'd)

5.7 Rates and Charges (Cont'd)

5.7.2 Voiceband Facilities <sup>[1]</sup> (Cont'd)

(B) Optional Arrangements (Cont'd)

<u>Supplemental Features</u>
<u>Echo Control</u>
<u>Echo Canceller, per circuit</u>
Monthly
<u>Rate</u>

Jurisdiction

Alabama	\$85.00
Missouri	85.00

[1] Effective February 1, 2020 Voiceband Services are grandfathered. Availability to current customers is limited to circuits in service at existing locations.

FACILITIES FOR INTERSTATE ACCESS

5 SPECIAL ACCESS (Cont'd)

5.7 Rates and Charges (Cont'd)

5.7.2 Voiceband Facilities <sup>[1]</sup> (Cont'd)

(B) Optional Arrangements (Cont'd)

<u>Jurisdiction</u>	<u>Supplemental Features</u> <u>Voiceband Facility Switching Arrangement</u> Monthly <u>Rate</u>
Alabama	\$7.00
Missouri	7.00

<sup>[1]</sup> Effective February 1, 2020 Voiceband Services are grandfathered. Availability to current customers is limited to circuits in service at existing locations.

FACILITIES FOR INTERSTATE ACCESS

5 SPECIAL ACCESS (Cont'd)

5.7 Rates and Charges (Cont'd)

5.7.2 Voiceband Facilities <sup>[1]</sup> (Cont'd)

(B) Optional Arrangements (Cont'd)

<u>Jurisdiction</u>	<u>Supplemental Features</u>	
	<u>Improved Return Loss Per Channel Termination Monthly Rate</u>	<u>Improved Termination Option Per Channel Termination Monthly Rate</u>
Alabama	\$3.71	\$9.90
Missouri	3.71	9.90

[1] Effective February 1, 2020 Voiceband Services are grandfathered. Availability to current customers is limited to circuits in service at existing locations.



FACILITIES FOR INTERSTATE ACCESS

5 SPECIAL ACCESS (Cont'd)

5.7 Rates and Charges (Cont'd)

5.7.2 Voiceband Facilities <sup>[1]</sup> (Cont'd)

(B) Optional Arrangements (Cont'd)

Supplemental Features  
Improved Equal Level Echo Path Loss  
Per Channel Termination

Monthly  
Rate

Jurisdiction

Alabama  
Missouri

\$3.75  
3.75

[1] Effective February 1, 2020 Voiceband Services are grandfathered. Availability to current customers is limited to circuits in service at existing locations.

FACILITIES FOR INTERSTATE ACCESS

5. SPECIAL ACCESS (Cont'd)

5.7 Rates and Charges (Cont'd)

5.7.3 Program Audio Facilities <sup>[1]</sup>

(A) Standard Arrangements - (200-3500 Hz)

<u>Jurisdiction</u>	<u>Special Transport</u> <u>(Per Airline Mile)</u>		<u>Channel Termination</u>		
	<u>Monthly Rate</u>	<u>Daily Rate</u>	<u>Nonrecurring Charge</u>	<u>Monthly Rate</u>	<u>Daily Rate</u>
Alabama	\$9.00	\$0.90	\$200.00	\$24.44	\$2.44
Missouri	16.29	1.63	200.00	31.60	3.14

[1] Effective February 1, 2020 Program Audio Services are grandfathered. Availability to current customers is limited to circuits in service at existing locations.

FACILITIES FOR INTERSTATE ACCESS

5. SPECIAL ACCESS (Cont'd)

5.7 Rates and Charges (Cont'd)

5.7.3 Program Audio Facilities <sup>[1]</sup> (Cont'd)

(B) Standard Arrangements - (100-5000 Hz)

<u>Jurisdiction</u>	<u>Special Transport</u> <u>(Per Airline Mile)</u>		<u>Nonrecurring</u> <u>Charge</u>	<u>Channel Termination</u>	
	<u>Monthly Rate</u>	<u>Daily Rate</u>		<u>Monthly</u> <u>Rate</u>	<u>Daily Rate</u>
Alabama	\$9.00	\$0.90	\$200.00	\$24.44	\$2.44
Missouri	16.29	1.63	200.00	31.60	3.14

<sup>[1]</sup> Effective February 1, 2020 Program Audio Services are grandfathered. Availability to current customers is limited to circuits in service at existing locations.

FACILITIES FOR INTERSTATE ACCESS

5. SPECIAL ACCESS (Cont'd)

5.7 Rates and Charges (Cont'd)

5.7.3 Program Audio Facilities <sup>[1]</sup> (Cont'd)

(C) Standard Arrangements - (50-8000 Hz)

<u>Jurisdiction</u>	<u>Special Transport</u> <u>(Per Airline Mile)</u>		<u>Nonrecurring</u> <u>Charge</u>	<u>Channel Termination</u>	
	<u>Monthly Rate</u>	<u>Daily Rate</u>		<u>Monthly</u> <u>Rate</u>	<u>Daily Rate</u>
Alabama	\$9.00	\$.90	\$200.00	\$24.44	\$2.44
Missouri	16.29	1.63	200.00	31.60	3.14

<sup>[1]</sup> Effective February 1, 2020 Program Audio Services are grandfathered. Availability to current customers is limited to circuits in service at existing locations.

Effective: October 4, 2022

Original Page 5-148

## FACILITIES FOR INTERSTATE ACCESS

5. SPECIAL ACCESS (Cont'd)5.7 Rates and Charges (Cont'd)5.7.3 Program Audio Facilities <sup>[1]</sup> (Cont'd)(D) Standard Arrangements - (50-15000 Hz)

<u>Jurisdiction</u>	<u>Special Transport</u> (Per Airline Mile)		<u>Channel Termination</u>		
	<u>Monthly Rate</u>	<u>Daily Rate</u>	<u>Nonrecurring Charge</u>	<u>Monthly Rate</u>	<u>Daily Rate</u>
Alabama	\$9.00	\$0.90	\$200.00	\$24.44	\$2.44
Missouri	16.29	1.63	200.00	31.60	3.14

[1] Effective February 1, 2020 Program Audio Services are grandfathered. Availability to current customers is limited to circuits in service at existing locations.

FACILITIES FOR INTERSTATE ACCESS

5. SPECIAL ACCESS (Cont'd)

5.7 Rates and Charges (Cont'd)

5.7.3 Program Audio Facilities <sup>[1]</sup> (Cont'd)

(E) Optional Arrangements – (50-15000 Hz Facilities only)

<u>Jurisdiction</u>	<u>Supplemental Features</u>	
	<u>Conditioning – Program Audio</u>	
	<u>Stereo Conditioning, per occurrence</u>	
	<u>Monthly</u>	<u>Daily</u>
	<u>Rate</u>	<u>Rate</u>
Alabama	\$1.00	\$.10
Missouri	1.00	.10

[1] Effective February 1, 2020 Program Audio Services are grandfathered. Availability to current customers is limited to circuits in service at existing locations.

FACILITIES FOR INTERSTATE ACCESS

5 SPECIAL ACCESS (Cont'd)

5.7 Rates and Charges (Cont'd)

5.7.3 Program Audio Facilities <sup>[1]</sup> (Cont'd)

(F) Optional Arrangements - (All Bandwidths)

<u>Jurisdiction</u>	<u>Supplemental Features</u>	
	<u>Program Audio Bridging (Per Port)</u>	
	<u>Monthly</u> <u>Rate</u>	<u>Daily</u> <u>Rate</u>
Alabama	\$1.00	\$.10
Missouri	1.00	.10

[1] Effective February 1, 2020 Program Audio Services are grandfathered. Availability to current customers is limited to circuits in service at existing locations.

FACILITIES FOR INTERSTATE ACCESS

5 SPECIAL ACCESS (Cont'd)

5.7 Rates and Charges (Cont'd)

5.7.3 Program Audio Facilities <sup>[1]</sup> (Cont'd)

(F) Optional Arrangements - (All Bandwidths) (Cont'd)

<u>Jurisdiction</u>	<u>Supplemental Features</u>	
	<u>Conditioning Program Audio - Zero Loss</u>	
	<u>Per Channel Termination</u>	
	<u>Monthly</u>	<u>Daily</u>
	<u>Rate</u>	<u>Rate</u>
Alabama	\$12.00	\$1.20
Missouri	12.00	1.20

<sup>[1]</sup> Effective February 1, 2020 Program Audio Services are grandfathered. Availability to current customers is limited to circuits in service at existing locations.



FACILITIES FOR INTERSTATE ACCESS

5 SPECIAL ACCESS (Cont'd)

5.7 Rates and Charges (Cont'd)

5.7.3 Program Audio Facilities <sup>[1]</sup> (Cont'd)

(F) Optional Arrangements - (All Bandwidths) (Cont'd)

<u>Jurisdiction</u>	<u>Supplemental Features</u>	
	<u>Conditioning Program Audio - Zero Loss</u>	
	<u>Per Channel Termination</u>	
	<u>Monthly</u>	<u>Daily</u>
	<u>Rate</u>	<u>Rate</u>
Alabama	\$12.00	\$1.20
Missouri	12.00	1.20

5.7.3 Reserved for Future Use

5.7.4 Reserved for Future Use

[1] Effective February 1, 2020 Program Audio Services are grandfathered. Availability to current customers is limited to circuits in service at existing locations.

FACILITIES FOR INTERSTATE ACCESS

5. SPECIAL ACCESS (Cont'd)

5.7 Rates and Charges (Cont'd)

5.7.5 Digital Data Service Facilities <sup>[1]</sup>  
(2.4, 4.8, 9.6, 19.2, 56, 64 Kbps)

(A) Standard Arrangements

<u>Jurisdiction</u>	<u>Special Transport</u>	<u>Channel Termination</u>		
	All Speeds (Per Airline Mile) <u>Monthly Rate</u>	All Speeds Nonrecurring <u>Charge</u>	2.4, 4.8, 9.6, 19.2 Kbps <u>Monthly Rate</u>	56, 64 Kbps <u>Monthly Rate</u>
Alabama	\$8.40	\$194.30	\$235.00	\$235.00
Missouri	8.40	183.30	235.00	235.00

<sup>1)</sup> Effective February 1, 2020 Digital Data Services are grandfathered. Availability to current customers is limited to circuits in service at existing locations.

FACILITIES FOR INTERSTATE ACCESS

5. SPECIAL ACCESS (Cont'd)

5.7 Rates and Charges (Cont'd)

5.7.5 Digital Data Service Facilities (Cont'd)  
(2.4, 4.8, 9.6, 19.2, 56, 64 Kbps)

(B) DDS Optional Payment Plan [1]

		Channel Termination				
		All Speeds Nonrecurring Charge	2.4, 4.8, 9.6, 19.2 Kbps Monthly Rates	1 Year MRC	3 Year MRC	5 Year MRC
<u>Jurisdiction</u>						
Alabama	\$0.00	\$65.38	\$57.88	\$50.38		
Missouri	0.00	41.80	36.45	33.55		

[1] Effective May 16, 2019 the DDS Optional Payment Plan will be grandfathered until the expiration date of the current term. Term renewals will not be offered on these plans going forward as of this effective date. Upon expiration of the current term, rates will revert to month-to-month.

FACILITIES FOR INTERSTATE ACCESS

5. SPECIAL ACCESS (Cont'd)

5.7 Rates and Charges (Cont'd)

5.7.5 Digital Data Service Facilities (Cont'd)  
(2.4, 4.8, 9.6, 19.2, 56, 64 Kbps)

(B) DDS Optional Payment Plan [1] (Cont'd)

	<u>Channel Termination</u>		
	<u>56, 64 Kbps</u>		
	<u>Monthly Rate</u>		
	<u>1 Year</u>	<u>3 Year</u>	<u>5 Year</u>
	<u>MRC</u>	<u>MRC</u>	<u>MRC</u>
<u>Jurisdiction</u>			
Alabama	\$67.00	\$59.00	\$51.00
Missouri	41.80	36.45	33.55

[1] Effective May 16, 2019 the DDS Optional Payment Plan will be grandfathered until the expiration date of the current term. Term renewals will not be offered on these plans going forward as of this effective date. Upon expiration of the current term, rates will revert to month-to-month.

FACILITIES FOR INTERSTATE ACCESS

5 SPECIAL ACCESS (Cont'd)

5.7 Rates and Charges (Cont'd)

5.7.5 Digital Data Service Facilities <sup>[1]</sup> (Cont'd)

(C) Optional Arrangements

<u>Jurisdiction</u>	<u>Supplemental Features</u>	
	<u>DDS Bridging (Per Port)</u> Monthly <u>Rate</u>	<u>Secondary Channel</u> Monthly <u>Rate</u>
Alabama	\$10.73	\$7.00
Missouri	10.73	7.00

<sup>[1]</sup> Effective February 1, 2020 Digital Data Services are grandfathered. Availability to current customers is limited to circuits in service at existing locations.

Effective: October 4, 2022

Original Page 5-157

## FACILITIES FOR INTERSTATE ACCESS

5. SPECIAL ACCESS (Cont'd)5.7 Rates and Charges (Cont'd)5.7.6 Multiplexing Arrangements

<u>Jurisdiction</u>	<u>DS1 to Voice</u>	
	<u>Nonrecurring Charge</u>	<u>Monthly Rate</u>
Alabama	\$850.00	\$170.00
Missouri	850.00	170.00

FACILITIES FOR INTERSTATE ACCESS

5. SPECIAL ACCESS (Cont'd)

5.7 Rates and Charges (Cont'd)

5.7.6 Multiplexing Arrangements (Cont'd)

	<u>DS3 to DS1 and/or E1**</u>	
	<u>Nonrecurring Charge</u>	<u>Monthly Rate</u>
<u>Jurisdiction</u>		
Alabama	\$450.00	\$1,591.00
Missouri	450.00	1,597.00

\*\* Where E1 service is available.

FACILITIES FOR INTERSTATE ACCESS

5 SPECIAL ACCESS (Cont'd)

5.7 Rates and Charges (Cont'd)

5.7.6 Multiplexing Arrangements <sup>[1]</sup> (Cont'd)

<u>Jurisdiction</u>	<u>Digital Data Carrier Multiplexer</u>	
	<u>Nonrecurring Charge</u>	<u>Monthly Rate</u>
Alabama	\$1,500.00	\$275.00
Missouri	1,500.00	275.00

<sup>[1]</sup> Effective February 1, 2020 Digital Data Services are grandfathered. Availability to current customers is limited to circuits in service at existing locations.



FACILITIES FOR INTERSTATE ACCESS

5 SPECIAL ACCESS (Cont'd)

5.7 Rates and Charges (Cont'd)

5.7.6 Multiplexing Arrangements <sup>[1]</sup> (Cont'd)

	<u>Digital Data Subrate Multiplexer</u>			
	<u>One DS0 to Twenty 2.4 Kbps</u>		<u>One DS0 to Ten 4.8 Kbps</u>	
<u>Jurisdiction</u>	<u>Nonrecurring Charge</u>	<u>Monthly Rate</u>	<u>Nonrecurring Charge</u>	<u>Monthly Rate</u>
Alabama	\$800.00	\$160.00	\$800.00	\$120.00
Missouri	800.00	160.00	800.00	120.00

<sup>[1]</sup> Effective February 1, 2020 Digital Data Services are grandfathered. Availability to current customers is limited to circuits in service at existing locations.

FACILITIES FOR INTERSTATE ACCESS

5 SPECIAL ACCESS (Cont'd)

5.7 Rates and Charges (Cont'd)

5.7.6 Multiplexing Arrangements <sup>[1]</sup> (Cont'd)

<u>Jurisdiction</u>	<u>Digital Data Subrate Multiplexer</u> <u>One DS0 Port to Five 9.6 Kbps</u>	
	<u>Nonrecurring Charge</u>	<u>Monthly Rate</u>
Alabama	\$800.00	\$100.00
Missouri	800.00	100.00

<sup>[1]</sup> Effective February 1, 2020 Digital Data Services are grandfathered. Availability to current customers is limited to circuits in service at existing locations.

FACILITIES FOR INTERSTATE ACCESS

5. SPECIAL ACCESS (Cont'd)

5.7 Rates and Charges (Cont'd)

5.7.7 High Capacity DS1 (1.544 Mbps) Facilities

(A) Standard Arrangements

(1) Channel Termination – End User

	<u>Nonrecurring Charge</u>	<u>Monthly Rate</u>
<u>Jurisdiction</u>		
Alabama	\$451.00	\$697.00
Missouri	455.00	699.00

(2) Channel Termination – POP

	<u>Nonrecurring Charge</u>	<u>Monthly Rate</u>
<u>Jurisdiction</u>		
Alabama	\$451.00	\$697.00
Missouri	455.00	699.00

FACILITIES FOR INTERSTATE ACCESS

5. SPECIAL ACCESS (Cont'd)

5.7 Rates and Charges (Cont'd)

5.7.7 High Capacity DS1 (1.544 Mbps) Facilities (Cont'd)

(A) Standard Arrangements (Cont'd)

<u>Jurisdiction</u>	<u>Special Transport Termination Monthly Rate</u>	<u>Special Transport (Per Airline Mile) Monthly Rate</u>
Alabama	\$285.00	\$50.00
Missouri	286.00	50.00

FACILITIES FOR INTERSTATE ACCESS

5 SPECIAL ACCESS (Cont'd)

5.7 Rates and Charges (Cont'd)

5.7.7 High Capacity DS1 (1.544 Mbps) Facilities (Cont'd)

(B) Optional Arrangements (Cont'd)

<u>Jurisdiction</u>	<u>Supplemental Features</u>	
	<u>Automatic Protection</u> <u>Nonrecurring</u> <u>Charge</u>	<u>Switching</u> <u>Monthly</u> <u>Rate</u>
Alabama	\$725.00	\$100.25
Missouri	725.00	100.25

FACILITIES FOR INTERSTATE ACCESS

5 SPECIAL ACCESS (Cont'd)

5.7 Rates and Charges (Cont'd)

5.7.8 High Capacity Digital FT1 Facilities <sup>[1]</sup>

(A) Standard Arrangement - 2 X 56 Kbps or 2 X 64 Kbps

	<u>Channel Termination</u>			
	<u>Nonrecurring Charge</u>	<u>Monthly Rate</u>	<u>Special Transport</u>	<u>Special Transport Termination</u>
Alabama	\$450.00	\$104.50	\$2.17	\$12.84
Missouri	450.00	114.95	5.00	20.00

<sup>[1]</sup> Effective February 1, 2020 Fractional T1 Services are grandfathered. Availability to current customers is limited to circuits in service at existing locations.

FACILITIES FOR INTERSTATE ACCESS

5 SPECIAL ACCESS (Cont'd)

5.7 Rates and Charges (Cont'd)

5.7.8 High Capacity Digital FT1 Facilities <sup>[1]</sup> (Cont'd)

(A) Standard Arrangement - 4 X 56 Kbps or 4 X 64 Kbps (Cont'd)

<u>Jurisdiction</u>	<u>Channel Termination</u>		<u>Special Transport</u>	<u>Special Transport Termination</u>
	<u>Nonrecurring Charge</u>	<u>Monthly Rate</u>		
Alabama	\$450.00	\$114.00	\$2.20	\$17.78
Missouri	450.00	122.55	5.70	28.58

[1] Effective February 1, 2020 Fractional T1 Services are grandfathered. Availability to current customers is limited to circuits in service at existing locations.

FACILITIES FOR INTERSTATE ACCESS

5 SPECIAL ACCESS (Cont'd)

5.7 Rates and Charges (Cont'd)

5.7.8 High Capacity Digital FT1 Facilities <sup>[1]</sup> (Cont'd)

(A) Standard Arrangement – 6 X 56 Kbps or 6 X 64 Kbps (Cont'd)

<u>Jurisdiction</u>	<u>Channel Termination</u>		<u>Special Transport</u>	<u>Special Transport Termination</u>
	<u>Nonrecurring Charge</u>	<u>Monthly Rate</u>		
Alabama	\$450.00	\$129.68	\$2.24	\$17.83
Missouri	450.00	129.20	6.65	38.10

<sup>[1]</sup> Effective February 1, 2020 Fractional T1 Services are grandfathered. Availability to current customers is limited to circuits in service at existing locations.



FACILITIES FOR INTERSTATE ACCESS

5 SPECIAL ACCESS (Cont'd)

5.7 Rates and Charges (Cont'd)

5.7.8 High Capacity Digital FT1 Facilities (Cont'd)

(B) FT1 Optional Payment Plan – 2 X 56 Kbps or 2 X 64 Kbps [1]

Channel Termination

<u>Jurisdiction</u>	<u>One Year Monthly Rate</u>	<u>Three Year Monthly Rate</u>	<u>Five Year Monthly Rate</u>	<u>Special Transport</u>	<u>Special Transport Termination</u>
Alabama	\$99.75	\$95.00	\$90.25	\$2.09	\$12.35
Missouri	110.00	99.00	88.00	5.00	20.00

[1] Effective May 16, 2019 the FT1 Optional Payment Plan will be grandfathered until the expiration date of the current term. Term renewals will not be offered on these plans going forward as of this effective date. Upon expiration of the current term, rates will revert to month-to-month.

FACILITIES FOR INTERSTATE ACCESS

5 SPECIAL ACCESS (Cont'd)

5.7 Rates and Charges (Cont'd)

5.7.8 High Capacity Digital FT1 Facilities (Cont'd)

(B) FT1 Optional Payment Plan – 4 X 56 Kbps or 4 X 64 Kbps [1] (Cont'd)

Channel Termination

<u>Jurisdiction</u>	<u>One Year Monthly Rate</u>	<u>Three Year Monthly Rate</u>	<u>Five Year Monthly Rate</u>
Alabama	\$109.25	\$104.50	\$99.75
Missouri	118.55	108.00	96.00

[1] Effective May 16, 2019 the FT1 Optional Payment Plan will be grandfathered until the expiration date of the current term. Term renewals will not be offered on these plans going forward as of this effective date. Upon expiration of the current term, rates will revert to month-to-month.

FACILITIES FOR INTERSTATE ACCESS

5 SPECIAL ACCESS (Cont'd)

5.7 Rates and Charges (Cont'd)

5.7.8 High Capacity Digital FT1 Facilities (Cont'd)

(B) FT1 Optional Payment Plan – 6 X 56 Kbps or 6 X 64 Kbps [1] (Cont'd)

Channel Termination

	<u>One Year Monthly Rate</u>	<u>Three Year Monthly Rate</u>	<u>Five Year Monthly Rate</u>	<u>Special Transport</u>	<u>Special Transport Termination</u>
<u>Jurisdiction</u>					
Alabama	\$125.00	\$120.00	\$109.25	\$2.16	\$17.10
Missouri	123.00	113.00	98.80	6.65	38.00

[1] Effective May 16, 2019 the FT1 Optional Payment Plan will be grandfathered until the expiration date of the current term. Term renewals will not be offered on these plans going forward as of this effective date. Upon expiration of the current term, rates will revert to month-to-month.

FACILITIES FOR INTERSTATE ACCESS

5. SPECIAL ACCESS (Cont'd)

5.7 Rates and Charges (Cont'd)

5.7.9 High Capacity Digital DS3 (44.736 Mbps) Facilities - Three System [1]

(A) Protected DS3 - With Company Electronics

First Channel Termination  
(End User/POP)

<u>Jurisdiction</u>	<u>Nonrecurring Charge</u>	<u>Month-to-Month Rate</u>
Alabama	\$2,505.00	\$6,532.00
Missouri	\$2,510.00	6,555.00

<u>Jurisdiction</u>	<u>One Year Monthly Rate [1]</u>	<u>Three Year Monthly Rate [1]</u>	<u>Five Year Monthly Rate [1]</u>	<u>Seven Year Monthly Rate [1]</u>
Alabama	\$3,078.33	\$2,916.32	\$2,592.28	\$2,430.26
Missouri	3,078.33	2,916.32	2,592.28	2,430.26

[1] Effective May 16, 2019 the DS3 High Capacity 1, 3, 5 and 7 Year Rate Plans will be grandfathered until the expiration date of the current term. Term renewals will not be offered on these plans going forward as of this effective date. Upon expiration of the current term, rates will revert to month-to-month.

FACILITIES FOR INTERSTATE ACCESS

5. SPECIAL ACCESS (Cont'd)

5.7 Rates and Charges (Cont'd)

5.7.9 High Capacity Digital DS3 (44.736 Mbps) Facilities - Three System [1]

(A) Protected DS3 - With Company Electronics (Cont'd)

Each Additional Channel Termination - Maximum of 2 (End User/POP)

<u>Jurisdiction</u>	<u>Nonrecurring Charge</u>	<u>Month-to-Month Rate</u>		
Alabama	\$951.05	\$6,532.00		
Missouri	951.05	6,555.00		
<u>Jurisdiction</u>	<u>One Year Monthly Rate [1]</u>	<u>Three Year Monthly Rate [1]</u>	<u>Five Year Monthly Rate [1]</u>	<u>Seven Year Monthly Rate [1]</u>
Alabama	\$3,078.33	\$2,916.32	\$2,592.28	\$2,430.26
Missouri	3,078.33	2,916.32	2,592.28	2,430.26

[1] Effective May 16, 2019 the DS3 High Capacity 1, 3, 5 and 7 Year Rate Plans will be grandfathered until the expiration date of the current term. Term renewals will not be offered on these plans going forward as of this effective date. Upon expiration of the current term, rates will revert to month-to-month.

FACILITIES FOR INTERSTATE ACCESS

5. SPECIAL ACCESS (Cont'd)

5.7 Rates and Charges (Cont'd)

5.7.9 High Capacity Digital DS3 (44.736 Mbps) Facilities - Three System [1] (Cont'd)

(B) Protected DS3 - Without Company Electronics

		<u>First Channel Termination</u> <u>(End User/POP)</u>			
		<u>Nonrecurring</u> <u>Charge</u>	<u>Month-to-Month</u> <u>Rate</u>		
<u>Jurisdiction</u>					
Alabama		\$1,875.00	\$6,532.00		
Missouri		1,875.00	6,555.00		
		<u>One Year</u> <u>Monthly</u> <u>Rate [1]</u>	<u>Three Year</u> <u>Monthly</u> <u>Rate [1]</u>	<u>Five Year</u> <u>Monthly</u> <u>Rate [1]</u>	<u>Seven Year</u> <u>Monthly</u> <u>Rate [1]</u>
<u>Jurisdiction</u>					
Alabama		\$3,078.33	\$2,916.32	\$2,592.28	\$2,430.26
Missouri		3,078.33	2,916.32	2,592.28	2,430.26

[1] Effective May 16, 2019 the DS3 High Capacity 1. 3. 5 and 7 Year Rate Plans will be grandfathered until the expiration date of the current term. Term renewals will not be offered on these plans going forward as of this effective date. Upon expiration of the current term, rates will revert to month-to-month.

Effective: October 4, 2022

Original Page 5-174

## FACILITIES FOR INTERSTATE ACCESS

5. SPECIAL ACCESS (Cont'd)5.7 Rates and Charges (Cont'd)5.7.9 High Capacity Digital DS3 (44.736 Mbps) Facilities - Three System [1] (Cont'd)(B) Protected DS3 - Without Electronics (Cont'd)Each Additional Channel Terminator - Maximum of 2  
(End User/POP)

<u>Jurisdiction</u>	<u>Nonrecurring Charge</u>	<u>Month-to-Month Rate</u>
Alabama	\$750.00	\$6,532.00
Missouri	750.00	6,555.00

<u>Jurisdiction</u>	<u>One Year Monthly Rate [1]</u>	<u>Three Year Monthly Rate [1]</u>	<u>Five Year Monthly Rate [1]</u>	<u>Seven Year Monthly Rate [1]</u>
Alabama	\$3,078.33	\$2,916.32	\$2,592.28	\$2,430.26
Missouri	3,078.33	2,916.32	2,592.28	2,430.26

[1] Effective May 16, 2019 the DS3 High Capacity 1, 3, 5 and 7 Year Rate Plans will be grandfathered until the expiration date of the current term. Term renewals will not be offered on these plans going forward as of this effective date. Upon expiration of the current term, rates will revert to month-to-month.

FACILITIES FOR INTERSTATE ACCESS

5. SPECIAL ACCESS (Cont'd)

5.7 Rates and Charges (Cont'd)

5.7.10 High Capacity Digital DS3 (44.736 Mbps) Facilities - Unlimited System [1]

(A) Protected DS3 - With Company Electronics

First Channel Termination

(End User/POP)

<u>Jurisdiction</u>	<u>Nonrecurring Charge</u>	<u>Month-to-Month Rate</u>			
Alabama	\$4,500.00	\$7,643.03			
Missouri	4,500.00	5,054.82			

<u>Jurisdiction</u>	<u>One Year Monthly Rate [1]</u>	<u>Three Year Monthly Rate [1]</u>	<u>Five Year Monthly Rate [1]</u>	<u>Seven Year Monthly Rate [1]</u>
Alabama	\$6,532.50	\$5,562.00	\$4,780.50	\$4,590.50
Missouri	6,471.75	5,234.50	4,985.25	4,320.36

[1] Effective May 16, 2019 the DS3 High Capacity 1. 3. 5 and 7 Year Rate Plans will be grandfathered until the expiration date of the current term. Term renewals will not be offered on these plans going forward as of this effective date. Upon expiration of the current term, rates will revert to month-to-month.



FACILITIES FOR INTERSTATE ACCESS

5. SPECIAL ACCESS (Cont'd)

5.7 Rates and Charges (Cont'd)

5.7.10 High Capacity Digital DS3 (44.736 Mbps) Facilities - Unlimited System [1] (Cont'd)

(A) Protected DS3 - With Company Electronics (Cont'd)

Each Additional Channel Termination

(EndUser/POP)

<u>Jurisdiction</u>	<u>Nonrecurring Charge</u>	<u>Month-to-Month Rate</u>
Alabama	\$951.05	\$944.78
Missouri	951.05	800.28

<u>Jurisdiction</u>	<u>One Year Monthly Charge [1]</u>	<u>Three Year Monthly Rate [1]</u>	<u>Five Year Monthly Rate [1]</u>	<u>Seven Year Monthly Rate [1]</u>
Alabama	\$807.50	\$698.00	\$574.50	\$416.25
Missouri	684.00	622.22	594.87	391.64

[1] Effective May 16, 2019 the DS3 High Capacity 1, 3, 5 and 7 Year Rate Plans will be grandfathered until the expiration date of the current term. Term renewals will not be offered on these plans going forward as of this effective date. Upon expiration of the current term, rates will revert to month-to-month.

FACILITIES FOR INTERSTATE ACCESS

5. SPECIAL ACCESS (Cont'd)

5.7 Rates and Charges (Cont'd)

5.7.10 High Capacity Digital DS3 (44.736 Mbps) Facilities - Unlimited System [1] (Cont'd)

(B) Protected DS3 - Without Company Electronics

First Channel Termination

(End User/POP)

<u>Jurisdiction</u>	<u>Nonrecurring Charge</u>	<u>Month-to-Month Rate</u>
Alabama	\$3,375.00	\$5,202.70
Missouri	3,375.00	4,896.44

<u>Jurisdiction</u>	<u>One Year Monthly Rate [1]</u>	<u>Three Year Monthly Rate [1]</u>	<u>Five Year Monthly Rate [1]</u>	<u>Seven Year Monthly Rate [1]</u>
Alabama	\$4,446.75	\$3,785.50	\$3,425.25	\$3,124.50
Missouri	4,184.99	3,750.25	3,393.25	3,095.50

[1] Effective May 16, 2019 the DS3 High Capacity 1, 3, 5 and 7 Year Rate Plans will be grandfathered until the expiration date of the current term. Term renewals will not be offered on these plans going forward as of this effective date. Upon expiration of the current term, rates will revert to month-to-month.

FACILITIES FOR INTERSTATE ACCESS

5. SPECIAL ACCESS (Cont'd)

5.7 Rates and Charges (Cont'd)

5.7.10 High Capacity Digital DS3 (44.736 Mbps) Facilities - Unlimited System [1] (Cont'd)

(B) Protected DS3 - Without Company Electronics (Cont'd)

Each Additional Channel Termination

(End User/POP)

<u>Jurisdiction</u>	<u>Nonrecurring Charge</u>	<u>Month-to-Month Rate</u>
Alabama	\$750.00	\$911.72
Missouri	750.00	903.24

<u>Jurisdiction</u>	<u>One Year Monthly Rate [1]</u>	<u>Three Monthly Rate [1]</u>	<u>Five Year Monthly Rate [1]</u>	<u>Seven Year Monthly Rate [1]</u>
Alabama	\$779.25	\$712.50	\$549.50	\$411.25
Missouri	772.00	705.75	544.50	448.25

[1] Effective May 16, 2019 the DS3 High Capacity 1, 3, 5 and 7 Year Rate Plans will be grandfathered until the expiration date of the current term. Term renewals will not be offered on these plans going forward as of this effective date. Upon expiration of the current term, rates will revert to month-to-month.

FACILITIES FOR INTERSTATE ACCESS

5. SPECIAL ACCESS (Cont'd)

5.7 Rates and Charges (Cont'd)

5.7.11 High Capacity Digital DS3 (44.736 Mbps) Facilities - Individual System [1]

(A) Protected DS3 Individual - With Company Electronics

Each Channel Termination  
(End User/POP)

<u>Jurisdiction</u>	<u>Nonrecurring Charge</u>	<u>Month-to-Month Rate</u>		
Alabama	\$951.05	\$6,532.00		
Missouri	951.05	6,555.00		
<u>Jurisdiction</u>	<u>One Year Monthly Rate [1]</u>	<u>Three Year Monthly Rate [1]</u>	<u>Five Year Monthly Rate [1]</u>	<u>Seven Year Monthly Rate [1]</u>
Alabama	\$3,078.33	\$2,916.32	\$2,592.28	\$2,430.26
Missouri	3,078.33	2,916.32	2,592.28	2,430.26

[1] Effective May 16, 2019 the DS3 High Capacity 1, 3, 5 and 7 Year Rate Plans will be grandfathered until the expiration date of the current term. Term renewals will not be offered on these plans going forward as of this effective date. Upon expiration of the current term, rates will revert to month-to-month.

FACILITIES FOR INTERSTATE ACCESS

5. SPECIAL ACCESS (Cont'd)

5.7 Rates and Charges (Cont'd)

5.7.11 High Capacity Digital DS3 (44.736 Mbps) Facilities - Individual System [1] (Cont'd)

(B) Protected DS3 Individual - Without Company Electronics

Each Channel Termination  
(End Usr/POP)

<u>Jurisdiction</u>	<u>Nonrecurring Charge</u>	<u>Month-to-Month Rate</u>
Alabama	\$750.00	\$6,532.00
Missouri	750.00	6,555.00

<u>Jurisdiction</u>	<u>One Year Nonrecurring Charge [1]</u>	<u>Three Year Monthly Rate [1]</u>	<u>Five Year Monthly Rate [1]</u>	<u>Seven Year Monthly Rate [1]</u>
Alabama	\$3,078.33	\$2,916.32	\$2,592.28	\$2,430.26
Missouri	3,078.33	2,916.32	2,592.28	2,430.26

5.7.12 Reserved for Future Use

[1] Effective May 16, 2019 the DS3 High Capacity 1. 3. 5 and 7 Year Rate Plans will be grandfathered until the expiration date of the current term. Term renewals will not be offered on these plans going forward as of this effective date. Upon expiration of the current term, rates will revert to month-to-month.

FACILITIES FOR INTERSTATE ACCESS

5. SPECIAL ACCESS (Cont'd)

5.7 Rates and Charges (Cont'd)

5.7.13 High Capacity Digital DS3 (44.736 Mbps) Facilities - Special Transport (Cont'd)

(A) DS3 Special Transport Facilities

3 System,  
Unlimited System,  
Individual Transport  
Per DS3, Per Airline Mile  
Monthly Rate

Jurisdiction

Alabama	\$467.00
Missouri	469.00

FACILITIES FOR INTERSTATE ACCESS

5. SPECIAL ACCESS (Cont'd)

5.7 Rates and Charges (Cont'd)

5.7.13 High Capacity Digital DS3 (44.736 Mbps) Facilities - Special Transport (Cont'd)

(B)

DS3 Special Transport Terminations

3 System,  
Unlimited System,  
Individual Transport,  
Per DS3, Per Termination  
Monthly Rate

Jurisdiction

Alabama	\$2,672.00
Missouri	2,681.00

FACILITIES FOR INTERSTATE ACCESS

5 SPECIAL ACCESS (Cont'd)

5.7 Rates and Charges (Cont'd)

5.7.14 High Capacity Digital DS3 (44.736 Mbps) Facilities

(A) DS3 Multiplexer Cross Connect Arrangement, Per Arrangement

Nonrecurring Charge

Jurisdiction

Alabama	\$65.00
Missouri	65.00



FACILITIES FOR INTERSTATE ACCESS

5. SPECIAL ACCESS (Cont'd)

5.7 Rates and Charges (Cont'd)

5.7.15 Four-Wire Voiceband and Digital Data Service (DDS) Rate Stability Plan (RSP) [1]

(A) Rates

RSP Monthly Recurring Charge

<u>Jurisdiction</u>	<u>Four Wire Voiceband</u>		<u>DDS</u>			
	<u>3 Year</u>	<u>5 Year</u>	<u>(2.4, 4.8, 9.6, 19.2 Kbps)</u>		<u>(56, 64 Kbps)</u>	
			<u>3 Year</u>	<u>5 Year</u>	<u>3 Year</u>	<u>5 Year</u>
Alabama	\$41.80	\$39.20	\$46.32	\$41.85	\$60.93	\$54.78
Missouri	36.41	34.15	36.45	33.55	36.45	33.55

Special Transport  
(Per Airline Mile)

<u>Jurisdiction</u>	<u>Voiceband</u>		<u>DDS (All Speeds)</u>	
	<u>3 Year</u>	<u>5 Year</u>	<u>3 Year</u>	<u>5 Year</u>
Alabama	\$4.28	\$4.01	\$4.22	\$3.77
Missouri	3.79	3.55	2.73	2.45

[1] Effective May 16, 2019 the Four-Wire and Digital Data Service Rate Stability Plan (RSP) will be grandfathered until the expiration date of the current term. Term renewals will not be offered on these plans going forward as of this effective date. Upon expiration of the current term, rates will revert to month-to-month.

FACILITIES FOR INTERSTATE ACCESS

5 SPECIAL ACCESS (Cont'd)

5.7 Rates and Charges (Cont'd)

5.7.16 DS1 Term Volume Plan (TVP) [1]

(A) Channel Termination, Per DS1 SAL  
(End User/POP)

(1) One Year Term

<u>Jurisdiction</u>	<u>Monthly Rate</u> <u>DS1 SAL</u> <u>Threshold Levels</u>			
	<u>Nonrecurring Charge,</u> <u>Thresholds</u>	<u>2-60</u>	<u>61-120</u>	<u>121-240</u>
Alabama	\$451.00	\$261.25	\$261.25	\$261.25
Missouri	455.00	261.25	261.25	261.25

[1] Effective May 16, 2019 the DS1 Term Volume Plan (TVP) will be grandfathered until the expiration date of the current term. Term renewals will not be offered on these plans going forward as of this effective date. Upon expiration of the current term, rates will revert to month-to-month.

FACILITIES FOR INTERSTATE ACCESS

5 SPECIAL ACCESS (Cont'd)

5.7 Rates and Charges (Cont'd)

5.7.16 DS1 Term Volume Plan (TVP) [1] (Cont'd)

(A) Channel Termination, Per DS1 SAL (Cont'd)  
(End User/POP)

(1) One Year Term (Cont'd)

<u>Jurisdiction</u>	<u>Monthly Rate</u>					
	<u>241-500</u>	<u>501-1000</u>	<u>1001-3000</u>	<u>3001-6000</u>	<u>6001-11,000</u>	<u>Over 11,000</u>
Alabama	\$261.25	\$261.25	\$261.25	\$261.25	\$261.25	\$261.25
Missouri	261.25	261.25	261.25	261.25	261.25	261.25

[1] Effective May 16, 2019 the DS1 Term Volume Plan (TVP) will be grandfathered until the expiration date of the current term. Term renewals will not be offered on these plans going forward as of this effective date. Upon expiration of the current term, rates will revert to month-to-month.

FACILITIES FOR INTERSTATE ACCESS

5 SPECIAL ACCESS (Cont'd)

5.7 Rates and Charges (Cont'd)

5.7.16 DS1 Term Volume Plan (TVP) [1] (Cont'd)

(A) Channel Termination, Per DS1 SAL (Cont'd)  
(End User/POP)

(2) Two Year Term

<u>Jurisdiction</u>	<u>Monthly Rate</u> <u>DS1 SAL</u> <u>Threshold Levels</u>			
	<u>Nonrecurring Charge,</u> <u>All Thresholds</u>	<u>2-60</u>	<u>61-120</u>	<u>121-240</u>
Alabama	\$451.00	\$261.25	\$261.25	\$261.25
Missouri	455.00	261.25	261.25	261.25

[1] Effective May 16, 2019 the DS1 Term Volume Plan (TVP) will be grandfathered until the expiration date of the current term. Term renewals will not be offered on these plans going forward as of this effective date. Upon expiration of the current term, rates will revert to month-to-month.

FACILITIES FOR INTERSTATE ACCESS

5 SPECIAL ACCESS (Cont'd)

5.7 Rates and Charges (Cont'd)

5.7.16 DS1 Term Volume Plan (TVP) [1] (Cont'd)

(A) Channel Termination, Per DS1 SAL (Cont'd)  
(End User/POP)

(2) Two Year Term (Cont'd)

Monthly Rate  
DS1 SAL  
Threshold Levels

<u>Jurisdiction</u>	<u>241-500</u>	<u>501-1000</u>	<u>1001-3000</u>	<u>3001-6000</u>	<u>6001-11,000</u>	<u>Over 11,000</u>
Alabama	\$261.25	\$261.25	\$261.25	\$261.25	\$261.25	\$261.25
Missouri	261.25	261.25	261.25	261.25	261.25	261.25

[1] Effective May 16, 2019 the DS1 Term Volume Plan (TVP) will be grandfathered until the expiration date of the current term. Term renewals will not be offered on these plans going forward as of this effective date. Upon expiration of the current term, rates will revert to month-to-month.

FACILITIES FOR INTERSTATE ACCESS

5 SPECIAL ACCESS (Cont'd)

5.7 Rates and Charges (Cont'd)

5.7.16 DS1 Term Volume Plan (TVP) [1] (Cont'd)

(A) Channel Termination, Per DS1 SAL (Cont'd)  
(End User/POP)

(3) Three Year Term

<u>Jurisdiction</u>	<u>Monthly Rate</u> <u>DS1 SAL</u> <u>Threshold Levels</u>			
	<u>Nonrecurring Charge,</u> <u>All Thresholds</u>	<u>2-60</u>	<u>61-120</u>	<u>121-240</u>
Alabama	\$451.00	\$247.50	247.50	\$247.50
Missouri	455.00	247.50	247.50	247.50

[1] Effective May 16, 2019 the DS1 Term Volume Plan (TVP) will be grandfathered until the expiration date of the current term. Term renewals will not be offered on these plans going forward as of this effective date. Upon expiration of the current term, rates will revert to month-to-month.

FACILITIES FOR INTERSTATE ACCESS

5 SPECIAL ACCESS (Cont'd)

5.7 Rates and Charges (Cont'd)

5.7.16 DS1 Term Volume Plan (TVP) (Cont'd)

(A) Channel Termination, Per DS1 SAL [1] (Cont'd)  
(End User/POP)

(3) Three Year Term (Cont'd)

Monthly Rate  
DS1 SAL  
Threshold Levels

<u>Jurisdiction</u>	<u>241-500</u>	<u>501-1000</u>	<u>1001-3000</u>	<u>3001-6000</u>	<u>6001-11,000</u>	<u>Over 11,000</u>
Alabama	\$247.50	\$247.50	\$247.50	\$247.50	\$247.50	\$247.50
Missouri	247.50	247.50	247.50	247.50	247.50	247.50

[1] Effective May 16, 2019 the DS1 Term Volume Plan (TVP) will be grandfathered until the expiration date of the current term. Term renewals will not be offered on these plans going forward as of this effective date. Upon expiration of the current term, rates will revert to month-to-month.

FACILITIES FOR INTERSTATE ACCESS

0-

5. SPECIAL ACCESS (Cont'd)

5.7 Rates and Charges (Cont'd)

5.7.16 DS1 Term Volume Plan (TVP) [1] (Cont'd)

(A) Channel Termination, Per DS1 SAL (Cont'd)  
(End User/POP)

(4) Five Year Term

<u>Jurisdiction</u>	<u>Monthly Rate</u> <u>DS1 SAL</u> <u>Threshold Levels</u>			
	<u>Nonrecurring Charge,</u> <u>All Thresholds</u>	<u>2-60</u>	<u>61-120</u>	<u>121-240</u>
Alabama	\$451.00	\$220.00	\$220.00	\$220.00
Missouri	455.00	220.00	220.00	220.00

[1] Effective May 16, 2019 the DS1 Term Volume Plan (TVP) will be grandfathered until the expiration date of the current term. Term renewals will not be offered on these plans going forward as of this effective date. Upon expiration of the current term, rates will revert to month-to-month.



FACILITIES FOR INTERSTATE ACCESS

5. SPECIAL ACCESS (Cont'd)

5.7 Rates and Charges (Cont'd)

5.7.16 DS1 Term Volume Plan (TVP) [1] (Cont'd)

(A) Channel Termination, Per DS1 SAL (Cont'd)  
(End User/POP)

(4) Five Year Term (Cont'd)

Monthly Rate  
DS1 SAL  
Threshold Levels

<u>Jurisdiction</u>	<u>241-500</u>	<u>501-1000</u>	<u>1001-3000</u>	<u>3001-6000</u>	<u>6001-11,000</u>	<u>Over 11,000</u>
Alabama	\$220.00	\$220.00	\$220.00	\$220.00	\$220.00	\$220.00
Missouri	220.00	220.00	220.00	220.00	220.00	220.00

5.7.17 Reserved for Future Use

[1] Effective May 16, 2019 the DS1 Term Volume Plan (TVP) will be grandfathered until the expiration date of the current term. Term renewals will not be offered on these plans going forward as of this effective date. Upon expiration of the current term, rates will revert to month-to-month.

Effective: October 4, 2022

Original Page 5-193

## FACILITIES FOR INTERSTATE ACCESS

5. Special Access Service (Cont'd)5.7 Rates and Charges (Cont'd)5.7.18 Ethernet Transport(A) Special Access Line(1) Month-to-Month Rates

- Per Point of Termination

Jurisdiction	Monthly Rates			Nonrecurring Installation Charges
	Within CO	0-3 Miles	Over 3 Miles	
<u>Alabama</u>				
10 Mbps	\$260.00	\$1,340.00	\$2,200.00	\$800.00
20 Mbps	\$930.00	\$1,360.00	\$2,240.00	\$900.00
50 Mbps	\$960.00	\$1,420.00	\$2,360.00	\$900.00
100 Mbps	\$1,020.00	\$2,040.00	\$3,910.00	\$1,000.00
150 Mbps	\$1,050.00	\$3,980.00	\$4,890.00	\$1,500.00
300 Mbps	\$1,090.00	\$4,450.00	\$5,380.00	\$5,000.00
450 Mbps	\$1,120.00	\$4,650.00	\$5,600.00	\$5,000.00
600 Mbps	\$1,140.00	\$4,830.00	\$5,810.00	\$10,000.00
1 Gbps	\$1,190.00	\$5,850.00	\$6,860.00	\$10,000.00
2.5 Gbps	\$1,785.00	\$9,765.00	\$11,430.00	\$10,000.00
10 Gbps	\$4,462.50	\$24,412.50	\$28,575.00	\$10,000.00

Jurisdiction	Monthly Rates			Nonrecurring Installation Charges
	Within CO	0-3 Miles	Over 3 Miles	
<u>Missouri</u>				
10 Mbps	\$260.00	\$1,340.00	\$2,200.00	\$800.00
20 Mbps	\$930.00	\$1,360.00	\$2,240.00	\$900.00
50 Mbps	\$960.00	\$1,420.00	\$2,360.00	\$900.00
100 Mbps	\$1,020.00	\$2,040.00	\$3,910.00	\$1,000.00
150 Mbps	\$1,050.00	\$3,980.00	\$4,890.00	\$1,500.00
300 Mbps	\$1,090.00	\$4,450.00	\$5,380.00	\$5,000.00
450 Mbps	\$1,120.00	\$4,650.00	\$5,600.00	\$5,000.00
600 Mbps	\$1,140.00	\$4,830.00	\$5,810.00	\$10,000.00
1 Gbps	\$1,190.00	\$5,850.00	\$6,860.00	\$10,000.00
2.5 Gbps	\$1,785.00	\$9,765.00	\$11,430.00	\$10,000.00
10 Gbps	\$4,462.50	\$24,412.50	\$28,575.00	\$10,000.00

Effective: October 4, 2022

Original Page 5-194

## FACILITIES FOR INTERSTATE ACCESS

5. Special Access Service (Cont'd)5.7 Rates and Charges (Cont'd)5.7.18 Ethernet Transport (Cont'd)(A) Special Access Line (Cont'd)(2) 1 Year Commitment Rates

- Per Point of Termination

Jurisdiction	Monthly Rates			Nonrecurring Installation Charges
	Within CO	0-3 Miles	Over 3 Miles	
<u>Alabama</u>				
10 Mbps	\$240.00	\$1,250.00	\$2,040.00	\$800.00
20 Mbps	\$860.00	\$1,270.00	\$2,090.00	\$900.00
50 Mbps	\$890.00	\$1,330.00	\$2,180.00	\$900.00
100 Mbps	\$940.00	\$1,910.00	\$3,640.00	\$1,000.00
150 Mbps	\$990.00	\$3,690.00	\$4,540.00	\$1,500.00
300 Mbps	\$1,020.00	\$4,130.00	\$5,000.00	\$5,000.00
450 Mbps	\$1,040.00	\$4,310.00	\$5,190.00	\$5,000.00
600 Mbps	\$1,050.00	\$4,480.00	\$5,410.00	\$10,000.00
1 Gbps	\$1,110.00	\$5,440.00	\$6,370.00	\$10,000.00
2.5 Gbps	\$1,665.00	\$9,060.00	\$10,620.00	\$10,000.00
10 Gbps	\$4,162.50	\$22,650.00	\$26,550.00	\$10,000.00

Jurisdiction	Monthly Rates			Nonrecurring Installation Charges
	Within CO	0-3 Miles	Over 3 Miles	
<u>Missouri</u>				
10 Mbps	\$240.00	\$1,250.00	\$2,040.00	\$800.00
20 Mbps	\$860.00	\$1,270.00	\$2,090.00	\$900.00
50 Mbps	\$890.00	\$1,330.00	\$2,180.00	\$900.00
100 Mbps	\$940.00	\$1,910.00	\$3,640.00	\$1,000.00
150 Mbps	\$990.00	\$3,690.00	\$4,540.00	\$1,500.00
300 Mbps	\$1,020.00	\$4,130.00	\$5,000.00	\$5,000.00
450 Mbps	\$1,040.00	\$4,310.00	\$5,190.00	\$5,000.00
600 Mbps	\$1,050.00	\$4,480.00	\$5,410.00	\$10,000.00
1 Gbps	\$1,110.00	\$5,440.00	\$6,370.00	\$10,000.00
2.5 Gbps	\$1,665.00	\$9,060.00	\$10,620.00	\$10,000.00
10 Gbps	\$4,162.50	\$22,650.00	\$26,550.00	\$10,000.00

Effective: October 4, 2022

Original Page 5-195

## FACILITIES FOR INTERSTATE ACCESS

5. Special Access Service (Cont'd)5.7 Rates and Charges (Cont'd)5.7.18 Ethernet Transport (Cont'd)(A) Special Access Line (Cont'd)(3) 3 Year Commitment Rates

- Per Point of Termination

Jurisdiction	Monthly Rates			Nonrecurring Installation Charges
	Within CO	0-3 Miles	Over 3 Miles	
<u>Alabama</u>				
10 Mbps	\$220.00	\$1,110.00	\$1,820.00	\$800.00
20 Mbps	\$470.00	\$1,120.00	\$1,840.00	\$900.00
50 Mbps	\$800.00	\$1,180.00	\$1,940.00	\$900.00
100 Mbps	\$840.00	\$1,690.00	\$3,220.00	\$1,000.00
150 Mbps	\$880.00	\$2,390.00	\$4,020.00	\$1,500.00
300 Mbps	\$910.00	\$3,210.00	\$4,420.00	\$5,000.00
450 Mbps	\$920.00	\$3,810.00	\$4,590.00	\$5,000.00
600 Mbps	\$930.00	\$3,970.00	\$4,780.00	\$10,000.00
1 Gbps	\$990.00	\$4,820.00	\$5,640.00	\$10,000.00
2.5 Gbps	\$1,485.00	\$8,025.00	\$9,390.00	\$10,000.00
10 Gbps	\$3,712.50	\$20,062.50	\$23,475.00	\$10,000.00

Jurisdiction	Monthly Rates			Nonrecurring Installation Charges
	Within CO	0-3 Miles	Over 3 Miles	
<u>Missouri</u>				
10 Mbps	\$220.00	\$1,110.00	\$1,820.00	\$800.00
20 Mbps	\$470.00	\$1,120.00	\$1,840.00	\$900.00
50 Mbps	\$800.00	\$1,180.00	\$1,940.00	\$900.00
100 Mbps	\$840.00	\$1,690.00	\$3,220.00	\$1,000.00
150 Mbps	\$880.00	\$2,390.00	\$4,020.00	\$1,500.00
300 Mbps	\$910.00	\$3,210.00	\$4,420.00	\$5,000.00
450 Mbps	\$920.00	\$3,810.00	\$4,590.00	\$5,000.00
600 Mbps	\$930.00	\$3,970.00	\$4,780.00	\$10,000.00
1 Gbps	\$990.00	\$4,820.00	\$5,640.00	\$10,000.00
2.5 Gbps	\$1,485.00	\$8,025.00	\$9,390.00	\$10,000.00
10 Gbps	\$3,712.50	\$20,062.50	\$23,475.00	\$10,000.00

Effective: October 4, 2022

Original Page 5-196

## FACILITIES FOR INTERSTATE ACCESS

5. Special Access Service (Cont'd)5.7 Rates and Charges (Cont'd)5.7.18 Ethernet Transport (Cont'd)(A) Special Access Line (Cont'd)(4) 5 Year Commitment Rates

- Per Point of Termination

Jurisdiction	Monthly Rates			Nonrecurring Installation Charges
	Within CO	0-3 Miles	Over 3 Miles	
<u>Alabama</u>				
10 Mbps	\$215.00	\$960.00	\$1,550.00	\$800.00
20 Mbps	\$400.00	\$970.00	\$1,600.00	\$900.00
50 Mbps	\$680.00	\$1,010.00	\$1,680.00	\$900.00
100 Mbps	\$730.00	\$1,460.00	\$3,100.00	\$1,000.00
150 Mbps	\$750.00	\$2,070.00	\$3,490.00	\$1,500.00
300 Mbps	\$780.00	\$2,790.00	\$3,840.00	\$5,000.00
450 Mbps	\$800.00	\$3,310.00	\$3,990.00	\$5,000.00
600 Mbps	\$810.00	\$3,450.00	\$4,150.00	\$10,000.00
1 Gbps	\$850.00	\$4,180.00	\$4,900.00	\$10,000.00
2.5 Gbps	\$1,275.00	\$6,975.00	\$8,160.00	\$10,000.00
10 Gbps	\$3,187.50	\$17,437.50	\$20,400.00	\$10,000.00

Jurisdiction	Monthly Rates			Nonrecurring Installation Charges
	Within CO	0-3 Miles	Over 3 Miles	
<u>Missouri</u>				
10 Mbps	\$215.00	\$960.00	\$1,550.00	\$800.00
20 Mbps	\$400.00	\$970.00	\$1,600.00	\$900.00
50 Mbps	\$680.00	\$1,010.00	\$1,680.00	\$900.00
100 Mbps	\$730.00	\$1,460.00	\$3,100.00	\$1,000.00
150 Mbps	\$750.00	\$2,070.00	\$3,490.00	\$1,500.00
300 Mbps	\$780.00	\$2,790.00	\$3,840.00	\$5,000.00
450 Mbps	\$800.00	\$3,310.00	\$3,990.00	\$5,000.00
600 Mbps	\$810.00	\$3,450.00	\$4,150.00	\$10,000.00
1 Gbps	\$850.00	\$4,180.00	\$4,900.00	\$10,000.00
2.5 Gbps	\$1,275.00	\$6,975.00	\$8,160.00	\$10,000.00
10 Gbps	\$3,187.50	\$17,437.50	\$20,400.00	\$10,000.00

FACILITIES FOR INTERSTATE ACCESS

5. Special Access Service (Cont'd)

5.7 Rates and Charges (Cont'd)

5.7.18 Ethernet Transport (Cont'd)

(B) Special Transport

(1) Month-to-Month Rates

Jurisdiction	Monthly Rates	
	<u>Termination</u>	<u>Per Mile</u>
<u>Alabama</u>		
10 Mbps	\$280.00	\$40.00
20 Mbps	\$290.00	\$50.00
50 Mbps	\$370.00	\$60.00
100 Mbps	\$600.00	\$100.00
150 Mbps	\$1,270.00	\$120.00
300 Mbps	\$1,910.00	\$200.00
450 Mbps	\$2,840.00	\$320.00
600 Mbps	\$3,530.00	\$490.00
1 Gbps	\$6,290.00	\$600.00
2.5 Gbps	\$9,435.00	\$900.00
10 Gbps	\$23,587.50	\$2,250.00
<u>Missouri</u>	<u>Termination</u>	<u>Per Mile</u>
10 Mbps	\$280.00	\$40.00
20 Mbps	\$290.00	\$50.00
50 Mbps	\$370.00	\$60.00
100 Mbps	\$600.00	\$100.00
150 Mbps	\$1,270.00	\$120.00
300 Mbps	\$1,910.00	\$200.00
450 Mbps	\$2,840.00	\$320.00
600 Mbps	\$3,530.00	\$490.00
1 Gbps	\$6,290.00	\$600.00
2.5 Gbps	\$9,435.00	\$900.00
10 Gbps	\$23,587.50	\$2,250.00

Effective: October 4, 2022

Original Page 5-198

## FACILITIES FOR INTERSTATE ACCESS

5. Special Access Service (Cont'd)5.7 Rates and Charges (Cont'd)5.7.18 Ethernet Transport (Cont'd)(B) Special Transport (Cont'd)(2) 1 Year Commitment Rates

Jurisdiction	Monthly Rates	
	<u>Termination</u>	<u>Per Mile</u>
<u>Alabama</u>		
10 Mbps	\$260.00	\$35.00
20 Mbps	\$280.00	\$45.00
50 Mbps	\$340.00	\$55.00
100 Mbps	\$570.00	\$85.00
150 Mbps	\$1,180.00	\$110.00
300 Mbps	\$1,770.00	\$190.00
450 Mbps	\$2,630.00	\$300.00
600 Mbps	\$3,290.00	\$470.00
1 Gbps	\$5,840.00	\$570.00
2.5 Gbps	\$8,760.00	\$855.00
10 Gbps	\$21,900.00	\$2,137.50
	<u>Termination</u>	<u>Per Mile</u>
<u>Missouri</u>		
10 Mbps	\$260.00	\$35.00
20 Mbps	\$280.00	\$45.00
50 Mbps	\$340.00	\$55.00
100 Mbps	\$570.00	\$85.00
150 Mbps	\$1,180.00	\$110.00
300 Mbps	\$1,770.00	\$190.00
450 Mbps	\$2,630.00	\$300.00
600 Mbps	\$3,290.00	\$470.00
1 Gbps	\$5,840.00	\$570.00
2.5 Gbps	\$8,760.00	\$855.00
10 Gbps	\$21,900.00	\$2,137.50

Effective: October 4, 2022

Original Page 5-199

## FACILITIES FOR INTERSTATE ACCESS

5. Special Access Service (Cont'd)5.7 Rates and Charges (Cont'd)5.7.18 Ethernet Transport (Cont'd)(B) Special Transport (Cont'd)(3) 3 Year Commitment Rates

Jurisdiction	Monthly Rates	
	<u>Termination</u>	<u>Per Mile</u>
<u>Alabama</u>		
10 Mbps	\$160.00	\$24.00
20 Mbps	\$170.00	\$30.00
50 Mbps	\$210.00	\$37.50
100 Mbps	\$315.00	\$55.00
150 Mbps	\$475.00	\$68.00
300 Mbps	\$800.00	\$115.00
450 Mbps	\$1,100.00	\$165.00
600 Mbps	\$1,375.00	\$215.00
1 Gbps	\$2,200.00	\$300.00
2.5 Gbps	\$3,300.00	\$450.00
10 Gbps	\$8,250.00	\$1,125.00
	<u>Termination</u>	<u>Per Mile</u>
<u>Missouri</u>		
10 Mbps	\$160.00	\$24.00
20 Mbps	\$170.00	\$30.00
50 Mbps	\$210.00	\$37.50
100 Mbps	\$315.00	\$55.00
150 Mbps	\$475.00	\$68.00
300 Mbps	\$800.00	\$115.00
450 Mbps	\$1,100.00	\$165.00
600 Mbps	\$1,375.00	\$215.00
1 Gbps	\$2,200.00	\$300.00
2.5 Gbps	\$3,300.00	\$450.00
10 Gbps	\$8,250.00	\$1,125.00



Effective: October 4, 2022

Original Page 5-200

## FACILITIES FOR INTERSTATE ACCESS

5. Special Access Service (Cont'd)5.7 Rates and Charges (Cont'd)5.7.18 Ethernet Transport (Cont'd)(B) Special Transport (Cont'd)(4) 5 Year Commitment Rates

Jurisdiction	Monthly Rates	
	<u>Termination</u>	<u>Per Mile</u>
<u>Alabama</u>		
10 Mbps	\$110.00	\$8.00
20 Mbps	\$120.00	\$10.00
50 Mbps	\$150.00	\$12.50
100 Mbps	\$225.00	\$18.00
150 Mbps	\$340.00	\$22.00
300 Mbps	\$575.00	\$36.00
450 Mbps	\$780.00	\$51.00
600 Mbps	\$985.00	\$65.00
1 Gbps	\$1,600.00	\$90.00
2.5 Gbps	\$2,400.00	\$135.00
10 Gbps	\$6,000.00	\$338.00
	<u>Termination</u>	<u>Per Mile</u>
<u>Missouri</u>		
10 Mbps	\$110.00	\$8.00
20 Mbps	\$120.00	\$10.00
50 Mbps	\$150.00	\$12.50
100 Mbps	\$225.00	\$18.00
150 Mbps	\$340.00	\$22.00
300 Mbps	\$575.00	\$36.00
450 Mbps	\$780.00	\$51.00
600 Mbps	\$985.00	\$65.00
1 Gbps	\$1,600.00	\$90.00
2.5 Gbps	\$2,400.00	\$135.00
10 Gbps	\$6,000.00	\$338.00

5.7.19 Reserved for Future Use

FACILITIES FOR INTERSTATE ACCESS

5. Special Access Service (Cont'd)

5.7 Rates and Charges (Cont'd)

5.7.20 Ethernet Virtual Private Line

(A) User-to-Network (UNI) Port Connection

(1) 10 Mbps

- Per Connection

	<u>Monthly Rates</u>			
	<u>Monthly</u>	<u>1 Year</u>	<u>2 Year</u>	
Alabama	\$380.00	\$360.00	\$340.00	
Missouri	\$380.00	\$360.00	\$340.00	

	<u>Monthly Rates</u>			<u>Nonrecurring Installation Charge*</u>
	<u>3 Year</u>	<u>5 Year</u>	<u>7 Year</u>	
Alabama	\$315.00	\$275.00	\$275.00	\$1,000.00
Missouri	\$315.00	\$275.00	\$275.00	\$1,000.00

\* Nonrecurring installation charges do not apply to the 7 year term.

FACILITIES FOR INTERSTATE ACCESS

5. Special Access Service (Cont'd)

5.7 Rates and Charges (Cont'd)

5.7.20 Ethernet Virtual Private Line (Cont'd)

(A) User-to-Network (UNI) Port Connection (Cont'd)

(2) 100 Mbps

- Per Connection

	<u>Monthly Rates</u>		
	<u>Monthly</u>	<u>1 Year</u>	<u>2 Year</u>
Alabama	\$380.00	\$360.00	\$340.00
Missouri	\$380.00	\$360.00	\$340.00

	<u>Monthly Rates</u>			<u>Nonrecurring Installation Charge*</u>
	<u>3 Year</u>	<u>5 Year</u>	<u>7 Year</u>	
Alabama	\$315.00	\$275.00	\$275.00	\$1,000.00
Missouri	\$315.00	\$275.00	\$275.00	\$1,000.00

\* Nonrecurring installation charges do not apply to the 7 year term.

FACILITIES FOR INTERSTATE ACCESS

5. Special Access Service (Cont'd)

5.7 Rates and Charges (Cont'd)

5.7.20 Ethernet Virtual Private Line (Cont'd)

(A) User-to-Network (UNI) Port Connection (Cont'd)

(3) 1000 Mbps

- Per Connection

	<u>Monthly Rates</u>		
	<u>Monthly</u>	<u>1 Year</u>	<u>2 Year</u>
Alabama	\$1,395.00	\$1,325.00	\$1,240.00
Missouri	\$1,395.00	\$1,325.00	\$1,240.00

	<u>Monthly Rates</u>			<u>Nonrecurring Installation Charge*</u>
	<u>3 Year</u>	<u>5 Year</u>	<u>7 Year</u>	
Alabama	\$1,155.00	\$1,010.00	\$960.00	\$3,000.00
Missouri	\$1,155.00	\$1,010.00	\$960.00	\$3,000.00

\* Nonrecurring installation charges do not apply to the 7 year term.

FACILITIES FOR INTERSTATE ACCESS

5. Special Access Service (Cont'd)

5.7 Rates and Charges (Cont'd)

5.7.20 Ethernet Virtual Private Line (Cont'd)

(A) User-to-Network (UNI) Port Connection (Cont'd)

(4) 10000 Mbps

- Per Connection

<u>Monthly Rates</u>			
	<u>Monthly</u>	<u>1 Year</u>	<u>2 Year</u>
Alabama	\$4,180.00	\$3,980.00	\$3,720.00
Missouri	\$4,180.00	\$3,980.00	\$3,720.00

<u>Monthly Rates</u>				
	<u>3 Year</u>	<u>5 Year</u>	<u>7 Year</u>	<u>Nonrecurring Installation Charge*</u>
Alabama	\$3,460.00	\$3,025.00	\$2,880.00	\$3,000.00
Missouri	\$3,460.00	\$3,025.00	\$2,880.00	\$3,000.00

\* Nonrecurring installation charges do not apply to the 7 year term.

FACILITIES FOR INTERSTATE ACCESS

5. Special Access Service (Cont'd)

5.7 Rates and Charges (Cont'd)

5.7.20 Ethernet Virtual Private Line (Cont'd)

(B) Network-to-Network (NNI) Port Connection

(1) 10 Mbps

- Per Connection

	<u>Monthly Rates</u>		
	<u>Monthly</u>	<u>1 Year</u>	<u>2 Year</u>
Alabama	\$380.00	\$360.00	\$340.00
Missouri	\$380.00	\$360.00	\$340.00

	<u>Monthly Rates</u>			<u>Nonrecurring Installation Charge*</u>
	<u>3 Year</u>	<u>5 Year</u>	<u>7 Year</u>	
Alabama	\$315.00	\$275.00	\$275.00	\$1,000.00
Missouri	\$315.00	\$275.00	\$275.00	\$1,000.00

\* Nonrecurring installation charges do not apply to the 7 year term.

FACILITIES FOR INTERSTATE ACCESS

5. Special Access Service (Cont'd)

5.7 Rates and Charges (Cont'd)

5.7.20 Ethernet Virtual Private Line (Cont'd)

(B) Network-to-Network (NNI) Port Connection (Cont'd)

(2) 100 Mbps

- Per Connection

	<u>Monthly Rates</u>			
	<u>Monthly</u>	<u>1 Year</u>	<u>2 Year</u>	
Alabama	\$380.00	\$360.00	\$340.00	
Missouri	\$380.00	\$360.00	\$340.00	

	<u>Monthly Rates</u>			<u>Nonrecurring Installation Charge*</u>
	<u>3 Year</u>	<u>5 Year</u>	<u>7 Year</u>	
Alabama	\$315.00	\$275.00	\$275.00	\$1,000.00
Missouri	\$315.00	\$275.00	\$275.00	\$1,000.00

\* Nonrecurring installation charges do not apply to the 7 year term.

FACILITIES FOR INTERSTATE ACCESS

5. Special Access Service (Cont'd)

5.7 Rates and Charges (Cont'd)

5.7.20 Ethernet Virtual Private Line (Cont'd)

(B) Network-to-Network (NNI) Port Connection (Cont'd)

(3) 1000 Mbps

- Per Connection

	<u>Monthly Rates</u>		
	<u>Monthly</u>	<u>1 Year</u>	<u>2 Year</u>
Alabama	\$1,395.00	\$1,325.00	\$1,240.00
Missouri	\$1,395.00	\$1,325.00	\$1,240.00

	<u>Monthly Rates</u>			<u>Nonrecurring Installation Charge*</u>
	<u>3 Year</u>	<u>5 Year</u>	<u>7 Year</u>	
Alabama	\$1,155.00	\$1,010.00	\$960.00	\$3,000.00
Missouri	\$1,155.00	\$1,010.00	\$960.00	\$3,000.00

\* Nonrecurring installation charges do not apply to the 7 year term.



FACILITIES FOR INTERSTATE ACCESS

5. Special Access Service (Cont'd)

5.7 Rates and Charges (Cont'd)

5.7.20 Ethernet Virtual Private Line (Cont'd)

(B) Network-to-Network (NNI) Port Connection (Cont'd)

(4) 10000 Mbps

- Per Connection

	<u>Monthly Rates</u>		
	<u>Monthly</u>	<u>1 Year</u>	<u>2 Year</u>
Alabama	\$4,180.00	\$3,980.00	\$3,720.00
Missouri	\$4,180.00	\$3,980.00	\$3,720.00

	<u>Monthly Rates</u>			<u>Nonrecurring Installation Charge*</u>
	<u>3 Year</u>	<u>5 Year</u>	<u>7 Year</u>	
Alabama	\$3,460.00	\$3,025.00	\$2,880.00	\$3,000.00
Missouri	\$3,460.00	\$3,025.00	\$2,880.00	\$3,000.00

\* Nonrecurring installation charges do not apply to the 7 year term.

FACILITIES FOR INTERSTATE ACCESS

5. Special Access Service (Cont'd)

5.7 Rates and Charges (Cont'd)

5.7.20 Ethernet Virtual Private Line (Cont'd)

(C) External Network-to-Network (E-NNI) Port Connection

(1) 1000 Mbps

- Per Connection

	<u>Monthly Rates</u>		
	<u>Monthly</u>	<u>1 Year</u>	<u>2 Year</u>
Alabama	\$1,395.00	\$1,325.00	\$1,240.00
Missouri	\$1,395.00	\$1,325.00	\$1,240.00

	<u>Monthly Rates</u>			<u>Nonrecurring Installation Charge*</u>
	<u>3 Year</u>	<u>5 Year</u>	<u>7 Year</u>	
Alabama	\$1,155.00	\$1,010.00	\$960.00	\$3,000.00
Missouri	\$1,155.00	\$1,010.00	\$960.00	\$3,000.00

\* Nonrecurring installation charges do not apply to the 7 year term.

FACILITIES FOR INTERSTATE ACCESS

5. Special Access Service (Cont'd)

5.7 Rates and Charges (Cont'd)

5.7.20 Ethernet Virtual Private Line (Cont'd)

(C) External Network-to-Network (E-NNI) Port Connection (Cont'd)

(2) 10000 Mbps

- Per Connection

	<u>Monthly Rates</u>		
	<u>Monthly</u>	<u>1 Year</u>	<u>2 Year</u>
Alabama	\$4,180.00	\$3,980.00	\$3,720.00
Missouri	\$4,180.00	\$3,980.00	\$3,720.00

	<u>Monthly Rates</u>			<u>Nonrecurring Installation Charge*</u>
	<u>3 Year</u>	<u>5 Year</u>	<u>7 Year</u>	
Alabama	\$3,460.00	\$3,025.00	\$2,880.00	\$3,000.00
Missouri	\$3,460.00	\$3,025.00	\$2,880.00	\$3,000.00

\* Nonrecurring installation charges do not apply to the 7 year term.

FACILITIES FOR INTERSTATE ACCESS

5. Special Access Service (Cont'd)

5.7 Rates and Charges (Cont'd)

5.7.20 Ethernet Virtual Private Line (Cont'd)

## FACILITIES FOR INTERSTATE ACCESS

5. Special Access Service (Cont'd)5.7 Rates and Charges (Cont'd)5.7.20 Ethernet Virtual Private Line (Cont'd)(D) Reserved(E) Ethernet Virtual Connection (EVC)/Operator Virtual Connection (OVC)(1) Month-to-Month

Monthly Rates	
3 Mbps	\$80.00
5 Mbps	\$175.00
7 Mbps	\$310.00
10 Mbps	\$465.00
20 Mbps	\$590.00
30 Mbps	\$630.00
40 Mbps	\$715.00
50 Mbps	\$740.00
60 Mbps	\$800.00
70 Mbps	\$925.00
80 Mbps	\$975.00
90 Mbps	\$1,050.00
100 Mbps	\$1,070.00
200 Mbps	\$1,140.00
300 Mbps	\$1,210.00
400 Mbps	\$1,280.00
500 Mbps	\$1,365.00
600 Mbps	\$1,505.00
700 Mbps	\$1,645.00
800 Mbps	\$1,755.00
900 Mbps	\$1,865.00
1000 Mbps	\$1,975.00

Rates are for both Alabama and Missouri exchanges listed within this Interstate Service Guide.

FACILITIES FOR INTERSTATE ACCESS

5. Special Access Service (Cont'd)

5.7 Rates and Charges (Cont'd)

5.7.20 Ethernet Virtual Private Line (Cont'd)

(E) Ethernet Virtual Connection (EVC)/Operator Virtual Connection (OVC)  
(Cont'd)

(2) 1 Year

Monthly Rates	
3 Mbps	\$78.00
5 Mbps	\$170.00
7 Mbps	\$295.00
10 Mbps	\$440.00
20 Mbps	\$560.00
30 Mbps	\$600.00
40 Mbps	\$680.00
50 Mbps	\$705.00
60 Mbps	\$775.00
70 Mbps	\$880.00
80 Mbps	\$950.00
90 Mbps	\$1,000.00
100 Mbps	\$1,020.00
200 Mbps	\$1,085.00
300 Mbps	\$1,150.00
400 Mbps	\$1,220.00
500 Mbps	\$1,300.00
600 Mbps	\$1,435.00
700 Mbps	\$1,565.00
800 Mbps	\$1,670.00
900 Mbps	\$1,775.00
1000 Mbps	\$1,880.00

Rates are for both Alabama and Missouri exchanges listed within this Interstate Service Guide.

FACILITIES FOR INTERSTATE ACCESS

5. Special Access Service (Cont'd)

5.7 Rates and Charges (Cont'd)

5.7.20 Ethernet Virtual Private Line (Cont'd)

(E) Ethernet Virtual Connection (EVC) /Operator Virtual Connection (OVC)  
(Cont'd)

(3) 2 Year

Monthly Rates	
3 Mbps	\$77.00
5 Mbps	\$160.00
7 Mbps	\$240.00
10 Mbps	\$325.00
20 Mbps	\$535.00
30 Mbps	\$570.00
40 Mbps	\$650.00
50 Mbps	\$670.00
60 Mbps	\$750.00
70 Mbps	\$840.00
80 Mbps	\$925.00
90 Mbps	\$950.00
100 Mbps	\$970.00
200 Mbps	\$1,030.00
300 Mbps	\$1,095.00
400 Mbps	\$1,160.00
500 Mbps	\$1,235.00
600 Mbps	\$1,365.00
700 Mbps	\$1,490.00
800 Mbps	\$1,590.00
900 Mbps	\$1,690.00
1000 Mbps	\$1,790.00

Rates are for both Alabama and Missouri exchanges listed within this Interstate Service Guide.

Effective: October 4, 2022

Original Page 5-215

## FACILITIES FOR INTERSTATE ACCESS

5. Special Access Service (Cont'd)5.7 Rates and Charges (Cont'd)5.7.20 Ethernet Virtual Private Line (Cont'd)(E) Ethernet Virtual Connection (EVC) /Operator Virtual Connection (OVC)  
(Cont'd)(4) 3 Year

Monthly Rates	
3 Mbps	\$75.00
5 Mbps	\$150.00
7 Mbps	\$185.00
10 Mbps	\$210.00
20 Mbps	\$505.00
30 Mbps	\$540.00
40 Mbps	\$615.00
50 Mbps	\$635.00
60 Mbps	\$725.00
70 Mbps	\$795.00
80 Mbps	\$875.00
90 Mbps	\$900.00
100 Mbps	\$915.00
200 Mbps	\$975.00
300 Mbps	\$1,035.00
400 Mbps	\$1,095.00
500 Mbps	\$1,170.00
600 Mbps	\$1,290.00
700 Mbps	\$1,410.00
800 Mbps	\$1,505.00
900 Mbps	\$1,600.00
1000 Mbps	\$1,695.00

Rates are for both Alabama and Missouri exchanges listed within this Interstate Service Guide.



FACILITIES FOR INTERSTATE ACCESS

5. Special Access Service (Cont'd)

5.7 Rates and Charges (Cont'd)

5.7.20 Ethernet Virtual Private Line (Cont'd)

(E) Ethernet Virtual Connection (EVC) /Operator Virtual Connection (OVC)  
(Cont'd)

(5) 5 Year

Monthly Rates	
3 Mbps	\$70.00
5 Mbps	\$145.00
7 Mbps	\$175.00
10 Mbps	\$200.00
20 Mbps	\$445.00
30 Mbps	\$475.00
40 Mbps	\$540.00
50 Mbps	\$555.00
60 Mbps	\$675.00
70 Mbps	\$695.00
80 Mbps	\$750.00
90 Mbps	\$775.00
100 Mbps	\$805.00
200 Mbps	\$855.00
300 Mbps	\$910.00
400 Mbps	\$960.00
500 Mbps	\$1,025.00
600 Mbps	\$1,130.00
700 Mbps	\$1,235.00
800 Mbps	\$1,320.00
900 Mbps	\$1,405.00
1000 Mbps	\$1,485.00

Rates are for both Alabama and Missouri exchanges listed within this Interstate Service Guide.

FACILITIES FOR INTERSTATE ACCESS

5. Special Access Service (Cont'd)

5.7 Rates and Charges (Cont'd)

5.7.20 Ethernet Virtual Private Line (Cont'd)

(E) Ethernet Virtual Connection (EVC) /Operator Virtual Connection (OVC)  
(Cont'd)

(6) 7 Year

Monthly Rates	
3 Mbps	\$70.00
5 Mbps	\$145.00
7 Mbps	\$175.00
10 Mbps	\$200.00
20 Mbps	\$420.00
30 Mbps	\$450.00
40 Mbps	\$510.00
50 Mbps	\$528.00
60 Mbps	\$625.00
70 Mbps	\$660.00
80 Mbps	\$700.00
90 Mbps	\$735.00
100 Mbps	\$762.00
200 Mbps	\$812.00
300 Mbps	\$862.00
400 Mbps	\$912.00
500 Mbps	\$972.00
600 Mbps	\$1,072.00
700 Mbps	\$1,172.00
800 Mbps	\$1,252.00
900 Mbps	\$1,332.00
1000 Mbps	\$1,410.00

Rates are for both Alabama and Missouri exchanges listed within this Interstate Service Guide.

Effective: October 4, 2022

Original Page 5-218

## FACILITIES FOR INTERSTATE ACCESS

5. Special Access Service (Cont'd)5.7 Rates and Charges (Cont'd)5.7.20 Ethernet Virtual Private Line (Cont'd)(F) Quality of Service (QoS)(1) Month-to-Month

	<u>Monthly Rates</u>		
	<u>Gold</u>	<u>Silver</u>	<u>Best Effort</u>
3 Mbps	\$137.00	\$16.00	\$0.00
5 Mbps	\$228.00	\$27.00	\$0.00
7 Mbps	\$319.00	\$37.00	\$0.00
10 Mbps	\$455.00	\$53.00	\$0.00
20 Mbps	\$590.00	\$103.00	\$0.00
30 Mbps	\$615.00	\$135.00	\$0.00
40 Mbps	\$630.00	\$159.00	\$0.00
50 Mbps	\$660.00	\$187.00	\$0.00
60 Mbps	\$680.00	\$200.00	\$0.00
70 Mbps	\$700.00	\$229.00	\$0.00
80 Mbps	\$750.00	\$260.00	\$0.00
90 Mbps	\$775.00	\$285.00	\$0.00

Rates are for both Alabama and Missouri exchanges listed within this Interstate Service Guide.

Effective: October 4, 2022

Original Page 5-219

## FACILITIES FOR INTERSTATE ACCESS

5. Special Access Service (Cont'd)5.7 Rates and Charges (Cont'd)5.7.20 Ethernet Virtual Private Line (Cont'd)(F) Quality of Service (QoS) (Cont'd)(1) Month-to-Month (Cont'd)

	Monthly Rates		
	<u>Gold</u>	<u>Silver</u>	<u>Best Effort</u>
100 Mbps	\$825.00	\$317.00	\$0.00
200 Mbps	\$940.00	\$381.00	\$0.00
300 Mbps	\$1,045.00	\$439.00	\$0.00
400 Mbps	\$1,140.00	\$493.00	\$0.00
500 Mbps	\$1,475.00	\$583.00	\$0.00
600 Mbps	\$1,655.00	\$657.00	\$0.00
700 Mbps	\$1,830.00	\$731.00	\$0.00
800 Mbps	\$1,965.00	\$793.00	\$0.00
900 Mbps	\$2,095.00	\$854.00	\$0.00
1000 Mbps	\$2,225.00	\$915.00	\$0.00

Rates are for both Alabama and Missouri exchanges listed within this Interstate Service Guide.

FACILITIES FOR INTERSTATE ACCESS

5. Special Access Service (Cont'd)

5.7 Rates and Charges (Cont'd)

5.7.20 Ethernet Virtual Private Line (Cont'd)

(F) Quality of Service (QoS) (Cont'd)

(2) 1 Year

	Monthly Rates		
	<u>Gold</u>	<u>Silver</u>	<u>Best Effort</u>
3 Mbps	\$130.00	\$14.00	\$0.00
5 Mbps	\$217.00	\$23.00	\$0.00
7 Mbps	\$304.00	\$32.00	\$0.00
10 Mbps	\$434.00	\$46.00	\$0.00
20 Mbps	\$562.00	\$90.00	\$0.00
30 Mbps	\$585.00	\$118.00	\$0.00
40 Mbps	\$600.00	\$139.00	\$0.00
50 Mbps	\$629.00	\$163.00	\$0.00
60 Mbps	\$650.00	\$180.00	\$0.00
70 Mbps	\$677.00	\$200.00	\$0.00
80 Mbps	\$725.00	\$225.00	\$0.00
90 Mbps	\$750.00	\$250.00	\$0.00

Rates are for both Alabama and Missouri exchanges listed within this Interstate Service Guide.

Effective: October 4, 2022

Original Page 5-221

## FACILITIES FOR INTERSTATE ACCESS

5. Special Access Service (Cont'd)5.7 Rates and Charges (Cont'd)5.7.20 Ethernet Virtual Private Line (Cont'd)(F) Quality of Service (QoS) (Cont'd)(2) 1 Year (Cont'd)

	Monthly Rates		
	<u>Gold</u>	<u>Silver</u>	<u>Best Effort</u>
100 Mbps	\$787.00	\$277.00	\$0.00
200 Mbps	\$895.00	\$333.00	\$0.00
300 Mbps	\$995.00	\$384.00	\$0.00
400 Mbps	\$1,087.00	\$431.00	\$0.00
500 Mbps	\$1,405.00	\$510.00	\$0.00
600 Mbps	\$1,575.00	\$575.00	\$0.00
700 Mbps	\$1,744.00	\$640.00	\$0.00
800 Mbps	\$1,870.00	\$694.00	\$0.00
900 Mbps	\$1,995.00	\$748.00	\$0.00
1000 Mbps	\$2,120.00	\$801.00	\$0.00

Rates are for both Alabama and Missouri exchanges listed within this Interstate Service Guide.

Effective: October 4, 2022

Original Page 5-222

## FACILITIES FOR INTERSTATE ACCESS

5. Special Access Service (Cont'd)5.7 Rates and Charges (Cont'd)5.7.20 Ethernet Virtual Private Line (Cont'd)(F) Quality of Service (QoS) (Cont'd)(3) 2 Year

	Monthly Rates		
	<u>Gold</u>	<u>Silver</u>	<u>Best Effort</u>
3 Mbps	\$124.00	\$12.00	\$0.00
5 Mbps	\$207.00	\$20.00	\$0.00
7 Mbps	\$289.00	\$27.00	\$0.00
10 Mbps	\$413.00	\$39.00	\$0.00
20 Mbps	\$534.00	\$77.00	\$0.00
30 Mbps	\$555.00	\$101.00	\$0.00
40 Mbps	\$570.00	\$119.00	\$0.00
50 Mbps	\$598.00	\$139.00	\$0.00
60 Mbps	\$615.00	\$145.00	\$0.00
70 Mbps	\$634.00	\$171.00	\$0.00
80 Mbps	\$675.00	\$195.00	\$0.00
90 Mbps	\$685.00	\$215.00	\$0.00

Rates are for both Alabama and Missouri exchanges listed within this Interstate Service Guide.

Effective: October 4, 2022

Original Page 5-223

## FACILITIES FOR INTERSTATE ACCESS

5. Special Access Service (Cont'd)5.7 Rates and Charges (Cont'd)5.7.20 Ethernet Virtual Private Line (Cont'd)(F) Quality of Service (QoS) (Cont'd)(3) 2 Year

	<u>Monthly Rates</u>		
	<u>Gold</u>	<u>Silver</u>	<u>Best Effort</u>
100 Mbps	\$749.00	\$237.00	\$0.00
200 Mbps	\$850.00	\$285.00	\$0.00
300 Mbps	\$945.00	\$329.00	\$0.00
400 Mbps	\$1,034.00	\$369.00	\$0.00
500 Mbps	\$1,335.00	\$437.00	\$0.00
600 Mbps	\$1,497.00	\$493.00	\$0.00
700 Mbps	\$1,658.00	\$549.00	\$0.00
800 Mbps	\$1,777.00	\$595.00	\$0.00
900 Mbps	\$1,896.00	\$641.00	\$0.00
1000 Mbps	\$2,015.00	\$687.00	\$0.00

Rates are for both Alabama and Missouri exchanges listed within this Interstate Service Guide.



Effective: October 4, 2022

Original Page 5-224

## FACILITIES FOR INTERSTATE ACCESS

5. Special Access Service (Cont'd)5.7 Rates and Charges (Cont'd)5.7.20 Ethernet Virtual Private Line (Cont'd)(F) Quality of Service (QoS) (Cont'd)(4) 3 Year

	Monthly Rates		
	<u>Gold</u>	<u>Silver</u>	<u>Best Effort</u>
3 Mbps	\$117.00	\$9.00	\$0.00
5 Mbps	\$195.00	\$16.00	\$0.00
7 Mbps	\$273.00	\$22.00	\$0.00
10 Mbps	\$390.00	\$31.00	\$0.00
20 Mbps	\$505.00	\$63.00	\$0.00
30 Mbps	\$525.00	\$83.00	\$0.00
40 Mbps	\$540.00	\$99.00	\$0.00
50 Mbps	\$565.00	\$115.00	\$0.00
60 Mbps	\$580.00	\$125.00	\$0.00
70 Mbps	\$600.00	\$141.00	\$0.00
80 Mbps	\$635.00	\$160.00	\$0.00
90 Mbps	\$675.00	\$180.00	\$0.00

Rates are for both Alabama and Missouri exchanges listed within this Interstate Service Guide.

FACILITIES FOR INTERSTATE ACCESS

5. Special Access Service (Cont'd)

5.7 Rates and Charges (Cont'd)

5.7.20 Ethernet Virtual Private Line (Cont'd)

(F) Quality of Service (QoS) (Cont'd)

(4) 3 Year (Cont'd)

	Monthly Rates		
	<u>Gold</u>	<u>Silver</u>	<u>Best Effort</u>
100 Mbps	\$710.00	\$197.00	\$0.00
200 Mbps	\$805.00	\$237.00	\$0.00
300 Mbps	\$895.00	\$273.00	\$0.00
400 Mbps	\$980.00	\$307.00	\$0.00
500 Mbps	\$1,265.00	\$363.00	\$0.00
600 Mbps	\$1,420.00	\$410.00	\$0.00
700 Mbps	\$1,570.00	\$457.00	\$0.00
800 Mbps	\$1,685.00	\$495.00	\$0.00
900 Mbps	\$1,800.00	\$533.00	\$0.00
1000 Mbps	\$1,910.00	\$571.00	\$0.00

Rates are for both Alabama and Missouri exchanges listed within this Interstate Service Guide.

Effective: October 4, 2022

Original Page 5-226

## FACILITIES FOR INTERSTATE ACCESS

5. Special Access Service (Cont'd)5.7 Rates and Charges (Cont'd)5.7.20 Ethernet Virtual Private Line (Cont'd)(F) Quality of Service (QoS) (Cont'd)(5) 5 Year

	Monthly Rates		
	<u>Gold</u>	<u>Silver</u>	<u>Best Effort</u>
3 Mbps	\$104.00	\$8.00	\$0.00
5 Mbps	\$173.00	\$14.00	\$0.00
7 Mbps	\$242.00	\$19.00	\$0.00
10 Mbps	\$345.00	\$27.00	\$0.00
20 Mbps	\$440.00	\$57.00	\$0.00
30 Mbps	\$460.00	\$75.00	\$0.00
40 Mbps	\$475.00	\$89.00	\$0.00
50 Mbps	\$495.00	\$103.00	\$0.00
60 Mbps	\$505.00	\$119.00	\$0.00
70 Mbps	\$525.00	\$127.00	\$0.00
80 Mbps	\$550.00	\$140.00	\$0.00
90 Mbps	\$580.00	\$155.00	\$0.00

Rates are for both Alabama and Missouri exchanges listed within this Interstate Service Guide.

FACILITIES FOR INTERSTATE ACCESS

5. Special Access Service (Cont'd)

5.7 Rates and Charges (Cont'd)

5.7.20 Ethernet Virtual Private Line (Cont'd)

(F) Quality of Service (QoS) (Cont'd)

(5) 5 Year (Cont'd)

	Monthly Rates		
	<u>Gold</u>	<u>Silver</u>	<u>Best Effort</u>
100 Mbps	\$620.00	\$179.00	\$0.00
200 Mbps	\$705.00	\$215.00	\$0.00
300 Mbps	\$785.00	\$247.00	\$0.00
400 Mbps	\$855.00	\$279.00	\$0.00
500 Mbps	\$1,110.00	\$329.00	\$0.00
600 Mbps	\$1,245.00	\$372.00	\$0.00
700 Mbps	\$1,375.00	\$415.00	\$0.00
800 Mbps	\$1,475.00	\$450.00	\$0.00
900 Mbps	\$1,575.00	\$485.00	\$0.00
1000 Mbps	\$1,670.00	\$519.00	\$0.00

Rates are for both Alabama and Missouri exchanges listed within this Interstate Service Guide.

Effective: October 4, 2022

Original Page 5-228

## FACILITIES FOR INTERSTATE ACCESS

5. Special Access Service (Cont'd)5.7 Rates and Charges (Cont'd)5.7.20 Ethernet Virtual Private Line (Cont'd)(F) Quality of Service (QoS) (Cont'd)(6) 7 Year

	<u>Monthly Rates</u>		
	<u>Gold</u>	<u>Silver</u>	<u>Best Effort</u>
3 Mbps	\$97.00	\$8.00	\$0.00
5 Mbps	\$162.00	\$14.00	\$0.00
7 Mbps	\$227.00	\$19.00	\$0.00
10 Mbps	\$324.00	\$27.00	\$0.00
20 Mbps	\$419.00	\$57.00	\$0.00
30 Mbps	\$437.00	\$75.00	\$0.00
40 Mbps	\$450.00	\$89.00	\$0.00
50 Mbps	\$468.00	\$103.00	\$0.00
60 Mbps	\$475.00	\$110.00	\$0.00
70 Mbps	\$500.00	\$127.00	\$0.00
80 Mbps	\$515.00	\$130.00	\$0.00
90 Mbps	\$550.00	\$140.00	\$0.00

Rates are for both Alabama and Missouri exchanges listed within this Interstate Service Guide.

FACILITIES FOR INTERSTATE ACCESS

5. Special Access Service (Cont'd)

5.7 Rates and Charges (Cont'd)

5.7.20 Ethernet Virtual Private Line (Cont'd)

(F) Quality of Service (QoS) (Cont'd)

(6) 7 Year (Cont'd)

	Monthly Rates		
	<u>Gold</u>	<u>Silver</u>	<u>Best Effort</u>
100 Mbps	\$589.00	\$179.00	\$0.00
200 Mbps	\$669.00	\$215.00	\$0.00
300 Mbps	\$744.00	\$247.00	\$0.00
400 Mbps	\$814.00	\$279.00	\$0.00
500 Mbps	\$1,053.00	\$329.00	\$0.00
600 Mbps	\$1,179.00	\$372.00	\$0.00
700 Mbps	\$1,305.00	\$415.00	\$0.00
800 Mbps	\$1,400.00	\$450.00	\$0.00
900 Mbps	\$1,495.00	\$485.00	\$0.00
1000 Mbps	\$1,589.00	\$519.00	\$0.00

Rates are for both Alabama and Missouri exchanges listed within this Interstate Service Guide.

FACILITIES FOR INTERSTATE ACCESS

5. Special Access Service (Cont'd)

5.7 Rates and Charges (Cont'd)

5.7.20 Ethernet Virtual Private Line (Cont'd)

(G) EVPL Reconfiguration

- Per EVC or QoS Established or Reconfigured

	<u>Nonrecurring Charge*</u>
Alabama	\$400.00
Missouri	\$400.00

(H) ICO NNI Trunk Connection (per EVC)

(1) 3 Mbps

- Per Connection

	<u>Monthly Rates</u>				<u>Nonrecurring Installation Charge**</u>
	<u>Monthly</u>	<u>1 Year</u>	<u>2 Year</u>	<u>3 Year</u>	
Alabama	\$555.00	\$460.00	\$380.00	\$330.00	\$400.00
Missouri	\$555.00	\$460.00	\$380.00	\$330.00	\$400.00

	<u>Monthly Rates</u>	
	<u>5 Year</u>	<u>7 Year **</u>
Alabama	\$290.00	\$250.00
Missouri	\$290.00	\$250.00

\* The EVPL Reconfiguration charge does not apply to EVPL arrangements ordered under a 7 year term commitment.

\*\* Nonrecurring installation charges do not apply to the 7 year term.

FACILITIES FOR INTERSTATE ACCESS

5. Special Access Service (Cont'd)

5.7 Rates and Charges (Cont'd)

5.7.20 Ethernet Virtual Private Line (Cont'd)

(H) ICO NNI Trunk Connection (per EVC) (Cont'd)

(2) 5 Mbps

- Per Connection

	<u>Monthly Rates</u>				<u>Nonrecurring Installation Charge*</u>
	<u>Monthly</u>	<u>1 Year</u>	<u>2 Year</u>	<u>3 Year</u>	
Alabama	\$625.00	\$520.00	\$430.00	\$365.00	\$460.00
Missouri	\$625.00	\$520.00	\$430.00	\$365.00	\$460.00

	<u>Monthly Rates</u>	
	<u>5 Year</u>	<u>7 Year *</u>
Alabama	\$315.00	\$280.00
Missouri	\$315.00	\$280.00

\* Nonrecurring installation charges do not apply to the 7 year term.



FACILITIES FOR INTERSTATE ACCESS

5. Special Access Service (Cont'd)

5.7 Rates and Charges (Cont'd)

5.7.20 Ethernet Virtual Private Line (Cont'd)

(H) ICO NNI Trunk Connection (per EVC) (Cont'd)

(3) 7 Mbps

- Per Connection

	<u>Monthly Rates</u>				<u>Nonrecurring Installation Charge*</u>
	<u>Monthly</u>	<u>1 Year</u>	<u>2 Year</u>	<u>3 Year</u>	
Alabama	\$715.00	\$590.00	\$485.00	\$415.00	\$530.00
Missouri	\$715.00	\$590.00	\$485.00	\$415.00	\$530.00

	<u>Monthly Rates</u>	
	<u>5 Year</u>	<u>7 Year *</u>
Alabama	\$360.00	\$310.00
Missouri	\$360.00	\$310.00

\* Nonrecurring installation charges do not apply to the 7 year term.

FACILITIES FOR INTERSTATE ACCESS

5. Special Access Service (Cont'd)

5.7 Rates and Charges (Cont'd)

5.7.20 Ethernet Virtual Private Line (Cont'd)

(H) ICO NNI Trunk Connection (per EVC) (Cont'd)

(4) 10 Mbps

- Per Connection

	<u>Monthly Rates</u>				<u>Nonrecurring Installation Charge*</u>
	<u>Monthly</u>	<u>1 Year</u>	<u>2 Year</u>	<u>3 Year</u>	
Alabama	\$820.00	\$680.00	\$565.00	\$485.00	\$605.00
Missouri	\$820.00	\$680.00	\$565.00	\$485.00	\$605.00

	<u>Monthly Rates</u>	
	<u>5 Year</u>	<u>7 Year *</u>
Alabama	\$415.00	\$360.00
Missouri	\$415.00	\$360.00

\* Nonrecurring installation charges do not apply to the 7 year term.

FACILITIES FOR INTERSTATE ACCESS

5. Special Access Service (Cont'd)

5.7 Rates and Charges (Cont'd)

5.7.20 Ethernet Virtual Private Line (Cont'd)

(H) ICO NNI Trunk Connection (per EVC) (Cont'd)

(5) 20 Mbps

- Per Connection

	<u>Monthly Rates</u>				<u>Nonrecurring Installation Charge*</u>
	<u>Monthly</u>	<u>1 Year</u>	<u>2 Year</u>	<u>3 Year</u>	
Alabama	\$970.00	\$805.00	\$670.00	\$580.00	\$690.00
Missouri	\$970.00	\$805.00	\$670.00	\$580.00	\$690.00

	<u>Monthly Rates</u>	
	<u>5 Year</u>	<u>7 Year *</u>
Alabama	\$495.00	\$430.00
Missouri	\$495.00	\$430.00

\* Nonrecurring installation charges do not apply to the 7 year term.

FACILITIES FOR INTERSTATE ACCESS

5. Special Access Service (Cont'd)

5.7 Rates and Charges (Cont'd)

5.7.20 Ethernet Virtual Private Line (Cont'd)

(H) ICO NNI Trunk Connection (per EVC) (Cont'd)

(6) 50 Mbps

- Per Connection

	<u>Monthly Rates</u>				<u>Nonrecurring Installation Charge*</u>
	<u>Monthly</u>	<u>1 Year</u>	<u>2 Year</u>	<u>3 Year</u>	
Alabama	\$1,220.00	\$1,015.00	\$840.00	\$725.00	\$805.00
Missouri	\$1,220.00	\$1,015.00	\$840.00	\$725.00	\$805.00

	<u>Monthly Rates</u>	
	<u>5 Year</u>	<u>7 Year *</u>
Alabama	\$625.00	\$540.00
Missouri	\$625.00	\$540.00

\* Nonrecurring installation charges do not apply to the 7 year term.

FACILITIES FOR INTERSTATE ACCESS

5. Special Access Service (Cont'd)

5.7 Rates and Charges (Cont'd)

5.7.20 Ethernet Virtual Private Line (Cont'd)

(H) ICO NNI Trunk Connection (per EVC) (Cont'd)

(7) 100 Mbps

- Per Connection

	<u>Monthly Rates</u>				<u>Nonrecurring Installation Charge*</u>
	<u>Monthly</u>	<u>1 Year</u>	<u>2 Year</u>	<u>3 Year</u>	
Alabama	\$1,625.00	\$1,350.00	\$1,120.00	\$970.00	\$920.00
Missouri	\$1,625.00	\$1,350.00	\$1,120.00	\$970.00	\$920.00

	<u>Monthly Rates</u>	
	<u>5 Year</u>	<u>7 Year *</u>
Alabama	\$830.00	\$720.00
Missouri	\$830.00	\$720.00

\* Nonrecurring installation charges do not apply to the 7 year term.

FACILITIES FOR INTERSTATE ACCESS

5. Special Access Service (Cont'd)

5.7 Rates and Charges (Cont'd)

5.7.20 Ethernet Virtual Private Line (Cont'd)

(H) ICO NNI Trunk Connection (per EVC) (Cont'd)

(8) 200 Mbps

- Per Connection

	<u>Monthly Rates</u>				<u>Nonrecurring Installation Charge*</u>
	<u>Monthly</u>	<u>1 Year</u>	<u>2 Year</u>	<u>3 Year</u>	
Alabama	\$2,760.00	\$2,300.00	\$1,910.00	\$1,660.00	\$1,380.00
Missouri	\$2,760.00	\$2,300.00	\$1,910.00	\$1,660.00	\$1,380.00

	<u>Monthly Rates</u>	
	<u>5 Year</u>	<u>7 Year *</u>
Alabama	\$1,415.00	\$1,220.00
Missouri	\$1,415.00	\$1,220.00

\* Nonrecurring installation charges do not apply to the 7 year term.

FACILITIES FOR INTERSTATE ACCESS

5. Special Access Service (Cont'd)

5.7 Rates and Charges (Cont'd)

5.7.20 Ethernet Virtual Private Line (Cont'd)

(H) ICO NNI Trunk Connection (per EVC) (Cont'd)

(9) 300 Mbps

- Per Connection

	<u>Monthly Rates</u>				<u>Nonrecurring Installation Charge*</u>
	<u>Monthly</u>	<u>1 Year</u>	<u>2 Year</u>	<u>3 Year</u>	
Alabama	\$3,925.00	\$3,270.00	\$2,715.00	\$2,360.00	\$1,380.00
Missouri	\$3,925.00	\$3,270.00	\$2,715.00	\$2,360.00	\$1,380.00

	<u>Monthly Rates</u>	
	<u>5 Year</u>	<u>7 Year *</u>
Alabama	\$2,010.00	\$1,730.00
Missouri	\$2,010.00	\$1,730.00

\* Nonrecurring installation charges do not apply to the 7 year term.

FACILITIES FOR INTERSTATE ACCESS

5. Special Access Service (Cont'd)

5.7 Rates and Charges (Cont'd)

5.7.20 Ethernet Virtual Private Line (Cont'd)

(H) ICO NNI Trunk Connection (per EVC) (Cont'd)

(10) 400 Mbps

- Per Connection

	<u>Monthly Rates</u>				<u>Nonrecurring Installation Charge*</u>
	<u>Monthly</u>	<u>1 Year</u>	<u>2 Year</u>	<u>3 Year</u>	
Alabama	\$5,970.00	\$4,970.00	\$4,135.00	\$3,595.00	\$1,380.00
Missouri	\$5,970.00	\$4,970.00	\$4,135.00	\$3,595.00	\$1,380.00

	<u>Monthly Rates</u>	
	<u>5 Year</u>	<u>7 Year *</u>
Alabama	\$3,060.00	\$2,640.00
Missouri	\$3,060.00	\$2,640.00

\* Nonrecurring installation charges do not apply to the 7 year term.



FACILITIES FOR INTERSTATE ACCESS

5. Special Access Service (Cont'd)

5.7 Rates and Charges (Cont'd)

5.7.20 Ethernet Virtual Private Line (Cont'd)

(H) ICO NNI Trunk Connection (per EVC) (Cont'd)

(11) 500 Mbps

- Per Connection

	<u>Monthly Rates</u>				<u>Nonrecurring Installation Charge*</u>
	<u>Monthly</u>	<u>1 Year</u>	<u>2 Year</u>	<u>3 Year</u>	
Alabama	\$6,685.00	\$5,570.00	\$4,635.00	\$4,025.00	\$1,380.00
Missouri	\$6,685.00	\$5,570.00	\$4,635.00	\$4,025.00	\$1,380.00

	<u>Monthly Rates</u>	
	<u>5 Year</u>	<u>7 Year *</u>
Alabama	\$3,430.00	\$2,950.00
Missouri	\$3,430.00	\$2,950.00

\* Nonrecurring installation charges do not apply to the 7 year term.

FACILITIES FOR INTERSTATE ACCESS

5. Special Access Service (Cont'd)

5.7 Rates and Charges (Cont'd)

5.7.20 Ethernet Virtual Private Line (Cont'd)

(H) ICO NNI Trunk Connection (per EVC) (Cont'd)

(12) 600 Mbps

- Per Connection

	<u>Monthly Rates</u>				<u>Nonrecurring Installation Charge*</u>
	<u>Monthly</u>	<u>1 Year</u>	<u>2 Year</u>	<u>3 Year</u>	
Alabama	\$8,005.00	\$6,670.00	\$5,555.00	\$4,830.00	\$1,380.00
Missouri	\$8,005.00	\$6,670.00	\$5,555.00	\$4,830.00	\$1,380.00

	<u>Monthly Rates</u>	
	<u>5 Year</u>	<u>7 Year *</u>
Alabama	\$4,110.00	\$3,540.00
Missouri	\$4,110.00	\$3,540.00

\* Nonrecurring installation charges do not apply to the 7 year term.

FACILITIES FOR INTERSTATE ACCESS

5. Special Access Service (Cont'd)

5.7 Rates and Charges (Cont'd)

5.7.20 Ethernet Virtual Private Line (Cont'd)

(H) ICO NNI Trunk Connection (per EVC) (Cont'd)

(13) 700 Mbps

- Per Connection

	<u>Monthly Rates</u>				<u>Nonrecurring Installation Charge*</u>
	<u>Monthly</u>	<u>1 Year</u>	<u>2 Year</u>	<u>3 Year</u>	
Alabama	\$8,065.00	\$6,720.00	\$5,750.00	\$5,085.00	\$1,380.00
Missouri	\$8,065.00	\$6,720.00	\$5,750.00	\$5,085.00	\$1,380.00

	<u>Monthly Rates</u>	
	<u>5 Year</u>	<u>7 Year *</u>
Alabama	\$4,370.00	\$3,760.00
Missouri	\$4,370.00	\$3,760.00

\* Nonrecurring installation charges do not apply to the 7 year term.

FACILITIES FOR INTERSTATE ACCESS

5. Special Access Service (Cont'd)

5.7 Rates and Charges (Cont'd)

5.7.20 Ethernet Virtual Private Line (Cont'd)

(G) ICO NNI Trunk Connection (per EVC) (Cont'd)

(14) 800 Mbps

- Per Connection

	<u>Monthly Rates</u>				<u>Nonrecurring Installation Charge*</u>
	<u>Monthly</u>	<u>1 Year</u>	<u>2 Year</u>	<u>3 Year</u>	
Alabama	\$8,280.00	\$6,900.00	\$5,915.00	\$5,225.00	\$1,380.00
Missouri	\$8,280.00	\$6,900.00	\$5,915.00	\$5,225.00	\$1,380.00

	<u>Monthly Rates</u>	
	<u>5 Year</u>	<u>7 Year *</u>
Alabama	\$4,485.00	\$3,860.00
Missouri	\$4,485.00	\$3,860.00

\* Nonrecurring installation charges do not apply to the 7 year term.

FACILITIES FOR INTERSTATE ACCESS

5. Special Access Service (Cont'd)

5.7 Rates and Charges (Cont'd)

5.7.20 Ethernet Virtual Private Line (Cont'd)

(H) ICO NNI Trunk Connection (per EVC) (Cont'd)

(15) 900 Mbps

- Per Connection

	<u>Monthly Rates</u>				<u>Nonrecurring Installation Charge*</u>
	<u>Monthly</u>	<u>1 Year</u>	<u>2 Year</u>	<u>3 Year</u>	
Alabama	\$8,510.00	\$7,085.00	\$6,065.00	\$5,360.00	\$1,380.00
Missouri	\$8,510.00	\$7,085.00	\$6,065.00	\$5,360.00	\$1,380.00

	<u>Monthly Rates</u>	
	<u>5 Year</u>	<u>7 Year *</u>
Alabama	\$4,600.00	\$3,960.00
Missouri	\$4,600.00	\$3,960.00

\* Nonrecurring installation charges do not apply to the 7 year term.

FACILITIES FOR INTERSTATE ACCESS

5. Special Access Service (Cont'd)

5.7 Rates and Charges (Cont'd)

5.7.20 Ethernet Virtual Private Line (Cont'd)

(H) ICO NNI Trunk Connection (per EVC) (Cont'd)

(16) 1000 Mbps

- Per Connection

	<u>Monthly Rates</u>				<u>Nonrecurring Installation Charge*</u>
	<u>Monthly</u>	<u>1 Year</u>	<u>2 Year</u>	<u>3 Year</u>	
Alabama	\$9,110.00	\$7,590.00	\$6,325.00	\$5,555.00	\$1,380.00
Missouri	\$9,110.00	\$7,590.00	\$6,325.00	\$5,555.00	\$1,380.00

	<u>Monthly Rates</u>	
	<u>5 Year</u>	<u>7 Year *</u>
Alabama	\$4,715.00	\$4,060.00
Missouri	\$4,715.00	\$4,060.00

\* Nonrecurring installation charges do not apply to the 7 year term.

Effective: October 4, 2022

Original Page 5-246

## FACILITIES FOR INTERSTATE ACCESS

5. Special Access Service (Cont'd)5.7 Rates and Charges (Cont'd)5.7.21 Ethernet Virtual Private Line(A) Ethernet Virtual Private Line Fixed Rate Term Plans(1) Service Element Term Plan – See 7 year terms in Section 5.7.20.(2) Bandwidth Profile Plan [1](a) EVPL Port

		<u>Non-Recurring Charge</u>
i.	10/100 Mbps, Per EVPL Port	
	• Monthly	\$ 600.00
	• 12 Months	\$ 600.00
	• 24 Months	\$ 600.00
	• 36 Months	\$ 600.00
	• 60 Months	\$ 600.00
ii.	1,000 Mbps, Per EVPL Port	
	• Monthly	\$ 1,200.00
	• 12 Months	\$ 1,200.00
	• 24 Months	\$ 1,200.00
	• 36 Months	\$ 1,200.00
	• 60 Months	\$ 1,200.00
iii.	10,000 Mbps, Per EVPL Port	
	• Monthly	\$ 3,000.00
	• 12 Months	\$ 3,000.00
	• 24 Months	\$ 3,000.00
	• 36 Months	\$ 3,000.00
	• 60 Months	\$ 3,000.00

[1] For the Bandwidth Profile, Section 5.7.21.A.2, the rates and charges in this section apply to all special access customers served by the Company.

Effective: October 4, 2022

Original Page 5-247

## FACILITIES FOR INTERSTATE ACCESS

5. Special Access Service (Cont'd)5.7 Rates and Charges (Cont'd)5.7.21 Ethernet Virtual Private Line (Cont'd)(A) Ethernet Virtual Private Line Fixed Rate Term Plans (Cont'd)(2) Bandwidth Profile Plan [1](Cont'd)(b) Customer Premises Bandwidthi. Per 10/100 Mbps Port

	Monthly Rates				
	<u>Monthly</u>	<u>12 Month</u>	<u>24 Month</u>	<u>36 Month</u>	<u>60 Month</u>
3 Bandwidth	\$374.00	\$352.00	\$330.00	\$307.00	\$285.00
5 Bandwidth	\$462.00	\$435.00	\$407.00	\$379.00	\$352.00
7 Bandwidth	\$589.00	\$554.00	\$519.00	\$483.00	\$448.00

ii. Per 10/100/1,000 Mbps Port

10 Bandwidth	\$757.00	\$712.00	\$667.00	\$621.00	\$576.00
--------------	----------	----------	----------	----------	----------

iii. Per 100/1,000 Mbps Port

20 Bandwidth	\$967.00	\$918.70	\$875.00	\$822.00	\$773.60
30 Bandwidth	\$1,034.00	\$982.30	\$935.00	\$878.90	\$827.20
40 Bandwidth	\$1,101.00	\$1,046.00	\$995.00	\$935.00	\$880.80
50 Bandwidth	\$1,168.00	\$1,109.60	\$1,055.00	\$992.80	\$934.40
60 Bandwidth	\$1,235.00	\$1,173.30	\$1,115.00	\$1,049.80	\$988.00
70 Bandwidth	\$1,302.00	\$1,236.90	\$1,175.00	\$1,106.70	\$1,041.60
80 Bandwidth	\$1,369.00	\$1,300.60	\$1,235.00	\$1,163.70	\$1,095.20
90 Bandwidth	\$1,436.00	\$1,364.20	\$1,295.00	\$1,220.60	\$1,148.80
100 Bandwidth	\$1,500.00	\$1,425.00	\$1,355.00	\$1,275.00	\$1,200.00

[1] For the Bandwidth Profile, Section 7.15.4.A.2, the rates and charges in this section apply to all special access customers served by the Company.



Effective: October 4, 2022

Original Page 5-248

## FACILITIES FOR INTERSTATE ACCESS

5. Special Access Service (Cont'd)5.7 Rates and Charges (Cont'd)5.7.21 Ethernet Virtual Private Line (Cont'd)(A) Ethernet Virtual Private Line Fixed Rate Term Plans (Cont'd)(2) Bandwidth Profile Plan [1] (Cont'd)(b) Customer Premises Bandwidthiv. Per 1,000 Mbps Port

	<u>Monthly Rates</u>				
	<u>Monthly</u>	<u>12 Month</u>	<u>24 Month</u>	<u>36 Month</u>	<u>60 Month</u>
100 Bandwidth	\$1,500.00	\$1,425.00	\$1,355.00	\$1,275.00	\$1,200.00
200 Bandwidth	\$2,089.00	\$1,984.60	\$1,885.00	\$1,775.70	\$1,671.20
300 Bandwidth	\$2,678.00	\$2,544.10	\$2,415.00	\$2,276.30	\$2,142.40
400 Bandwidth	\$3,267.00	\$3,103.70	\$2,945.00	\$2,777.00	\$2,613.60
500 Bandwidth	\$3,856.00	\$3,663.20	\$3,475.00	\$3,277.60	\$3,084.80
600 Bandwidth	\$4,445.00	\$4,222.80	\$4,005.00	\$3,778.30	\$3,556.00
700 Bandwidth	\$5,034.00	\$4,782.30	\$4,535.00	\$4,278.90	\$4,027.20
800 Bandwidth	\$5,623.00	\$5,341.90	\$5,065.00	\$4,779.60	\$4,498.40
900 Bandwidth	\$6,212.00	\$5,901.40	\$5,595.00	\$5,280.20	\$4,969.60
1,000 Bandwidth	\$6,800.00	\$6,460.00	\$6,125.00	\$5,780.20	\$5,440.00

v. Per 10,000 Mbps Port \*

	<u>Monthly</u>
2 Gbps Bandwidth	\$7,191.00
3 Gbps Bandwidth	\$7,581.00
4 Gbps Bandwidth	\$7,972.00
5 Gbps Bandwidth	\$8,362.00
6 Gbps Bandwidth	\$8,753.00
7 Gbps Bandwidth	\$9,143.00
8 Gbps Bandwidth	\$9,534.00
9 Gbps Bandwidth	\$9,924.00
10 Gbps Bandwidth	\$10,316.00

\* Available where facilities exist.

[1] For the Bandwidth Profile, Section 5.7.21.(B), the rates and charges in this section apply to all special access customers served by the Company.

## FACILITIES FOR INTERSTATE ACCESS

5. Special Access Service (Cont'd)5.7 Rates and Charges (Cont'd)5.7.21 Ethernet Virtual Private Line (Cont'd)(B) Ethernet Virtual Private Line Fixed Rate Term Plans (Cont'd)(2) Bandwidth Profile Plan [1] (Cont'd)(c) Ethernet Virtual Connection (EVC) / Operator Virtual Connection (OVC) [2]

	<u>Rate</u>
Monthly Per EVC/OVC Per Port	\$50.00

(d) Network to Network (NNI) Port Connection

	<u>Monthly Rate</u>
i.. 1,000 Mbps	
• Monthly	\$ 3,585.74
• 12 Months	\$ 3,414.99
• 24 Months	\$ 3,252.38
• 36 Months	\$ 3,097.50
• 60 Months	\$ 2,950.00
ii.. 10,000 Mbps	
• Monthly	\$ 10,757.23
• 12 Months	\$ 10,244.98
• 24 Months	\$ 9,757.13
• 36 Months	\$ 9,292.50
• 60 Months	\$ 8,850.00

(e) Quality of Service (QoS)

See QoS rates in Section 5.7.20

[1] For the Bandwidth Profile, Section 7.15.4.A.2, the rates and charges in this section apply to all special access customers served by the Company.

[2] Rates for the Ethernet Virtual Connection (EVC)/Operator Virtual Connection (OVC) and Network to Network (NNI) Port Connection displayed on this page are available for the Bandwidth Profile only.

FACILITIES FOR INTERSTATE ACCESS

5. Special Access Service (Cont'd)

5.7 Rates and Charges (Cont'd)

5.7.21 Ethernet Virtual Private Line (Cont'd)

(A) Ethernet Virtual Private Line Fixed Rate Term Plans (Cont'd)

(3) High Volume Based Plan

(a) 7 Year - UNI

Monthly Rates

<u>100 Mbps</u>	<u>200 Mbps</u>	<u>300 Mbps</u>	<u>400 Mbps</u>	<u>500 Mbps</u>	<u>600 Mbps</u>
\$1,408.00	\$1,940.00	\$2,240.00	\$2,530.00	\$2,755.00	\$2,945.00

Monthly Rates

<u>700 Mbps</u>	<u>800 Mbps</u>	<u>900 Mbps</u>	<u>1000 Mbps</u>	<u>1400 Mbps</u>	<u>2000 Mbps</u>
\$3,145.00	\$3,311.00	\$3,536.00	\$3,726.00	\$4,256.00	\$5,051.00

(b) 7 Year - NNI

Monthly Rates

<u>1000 Mbps</u>	<u>10 Gbps</u>
\$0.00	\$0.00

FACILITIES FOR INTERSTATE ACCESS

5. Special Access Service (Cont'd)

5.7 Rates and Charges (Cont'd)

5.7.21 Ethernet Virtual Private Line (Cont'd)

(A) Ethernet Virtual Private Line Fixed Rate Term Plans (Cont'd)

(3) High Volume Based Plan (Cont'd)

(c) 7 Year – OAM EVC

Monthly Rates

5  
Mbps  
\$25.00

(d) 7 Year – Additional EVC Connection Charge

Monthly Rates

\$25.00

(e) ICO NNI Trunk Connection (Per Connection)

Monthly Rates

	<u>1000 Mbps (1 Gbps)</u>	<u>10000 Mbps (10 Gbps)</u>
Alabama	\$0.00	\$0.00
Missouri	\$0.00	\$0.00

FACILITIES FOR INTERSTATE ACCESS

5. Special Access Service (Cont'd)

5.7 Rates and Charges (Cont'd)

5.7.21 Ethernet Virtual Private Line (Cont'd)

(A) Ethernet Virtual Private Line Fixed Rate Term Plans (Cont'd)

(4) Low Volume Based Plan

(a) 7 Year - UNI

	Monthly Rates					
	<u>100 Mbps</u>	<u>200 Mbps</u>	<u>400 Mbps</u>	<u>600 Mbps</u>	<u>800 Mbps</u>	<u>1000 Mbps</u>
Alabama	\$908.00	\$1,585.00	\$2,250.00	\$2,615.00	\$2,781.00	\$2,965.00
Missouri	\$908.00	\$1,585.00	\$2,250.00	\$2,615.00	\$2,781.00	\$2,965.00

(b) 7 Year - NNI

	Monthly Rates	
	<u>1000 Mbps (1 Gbps)</u>	<u>10000 Mbps (10 Gbps)</u>
Alabama	\$960.00	\$2,880.00
Missouri	\$960.00	\$2,880.00

FACILITIES FOR INTERSTATE ACCESS

5. Special Access Service (Cont'd)

5.7 Rates and Charges (Cont'd)

5.7.21 Ethernet Virtual Private Line (Cont'd)

(A) Ethernet Virtual Private Line Fixed Rate Term Plans (Cont'd)

(4) Low Volume Based Plan (Cont'd)

(c) 7 Year – Additional EVC Connection Charge

Monthly Rates

Alabama	\$250.00
Missouri	\$250.00

(d) ICO NNI Trunk Connection (Per Connection)

Monthly Rates

	<u>1000 Mbps</u> <u>(1 Gbps)</u>	<u>10000 Mbps</u> <u>(10 Gbps)</u>
Alabama	\$960.00	\$2,880.00
Missouri	\$960.00	\$2,880.00

FACILITIES FOR INTERSTATE ACCESS

5. Special Access Service (Cont'd)

5.7 Rates and Charges (Cont'd)

5.7.22 Optical Wavelength Service (OWS)

(A) Channel Termination

(1) Month-to Month

- OC3

Per Connection

<u>Monthly Rates</u>			<u>Nonrecurring Installation Charge</u>
<u>Within CO</u>	<u>0-3 Miles</u>	<u>Over 3 Miles</u>	
\$240.00	\$2,200.00	\$2,530.00	\$7,500.00

- OC12

Per Connection

<u>Monthly Rates</u>			<u>Nonrecurring Installation Charge</u>
<u>Within CO</u>	<u>0-3 Miles</u>	<u>Over 3 Miles</u>	
\$420.00	\$2,565.00	\$2,950.00	\$7,500.00

- OC48

Per Connection

<u>Monthly Rates</u>			<u>Nonrecurring Installation Charge</u>
<u>Within CO</u>	<u>0-3 Miles</u>	<u>Over 3 Miles</u>	
\$900.00	\$4,740.00	\$5,455.00	\$7,500.00

FACILITIES FOR INTERSTATE ACCESS

5. Special Access Service (Cont'd)

5.7 Rates and Charges (Cont'd)

5.7.22 Optical Wavelength Service (OWS) (Cont'd)

(A) Channel Termination (Cont'd)

(1) Month-to Month (Cont'd)

- OC192  
Per Connection

<u>Monthly Rates</u>			<u>Nonrecurring Installation Charge</u>
<u>Within CO</u>	<u>0-3 Miles</u>	<u>Over 3 Miles</u>	
\$1,800.00	\$5,940.00	\$6,835.00	\$7,500.00

- Gigabit Ethernet  
Per Connection

<u>Monthly Rates</u>			<u>Nonrecurring Installation Charge</u>
<u>Within CO</u>	<u>0-3 Miles</u>	<u>Over 3 Miles</u>	
\$600.00	\$3,660.00	\$4,215.00	\$7,500.00

- 10 G LAN  
Per Connection

<u>Monthly Rates</u>			<u>Nonrecurring Installation Charge</u>
<u>Within CO</u>	<u>0-3 Miles</u>	<u>Over 3 Miles</u>	
\$1,800.00	\$5,940.00	\$6,835.00	\$7,500.00



FACILITIES FOR INTERSTATE ACCESS

5. Special Access Service (Cont'd)

5.7 Rates and Charges (Cont'd)

5.7.22 Optical Wavelength Service (OWS) (Cont'd)

(A) Channel Termination (Cont'd)

(1) Month-to-Month (Cont'd)

- 10 G LAN  
Per Connection

<u>Monthly Rates</u>			<u>Nonrecurring Installation Charge</u>
<u>Within CO</u>	<u>0-3 Miles</u>	<u>Over 3 Miles</u>	
\$1,800.00	\$5,940.00	\$6,835.00	\$7,500.00

- OTU1  
Per Connection

<u>Monthly Rates</u>			<u>Nonrecurring Installation Charge</u>
<u>Within CO</u>	<u>0-3 Miles</u>	<u>Over 3 Miles</u>	
\$900.00	\$4,740.00	\$5,455.00	\$7,500.00

- OTU2  
Per Connection

<u>Monthly Rates</u>			<u>Nonrecurring Installation Charge</u>
<u>Within CO</u>	<u>0-3 Miles</u>	<u>Over 3 Miles</u>	
\$1,800.00	\$5,940.00	\$6,835.00	\$7,500.00

- OTU3  
Per Connection

<u>Monthly Rates</u>			<u>Nonrecurring Installation Charge</u>
<u>Within CO</u>	<u>0-3 Miles</u>	<u>Over 3 Miles</u>	
\$4,500.00	\$19,650.00	\$22,605.00	\$7,500.00

FACILITIES FOR INTERSTATE ACCESS

5. Special Access Service (Cont'd)

5.7 Rates and Charges (Cont'd)

5.7.22 Optical Wavelength Service (OWS) (Cont'd)

(A) Channel Termination (Cont'd)

(1) Month-to-Month (Cont'd)

- 100 GB Ethernet  
Per Connection

<u>Monthly Rates</u>			<u>Nonrecurring Installation Charge</u>
<u>Within CO</u>	<u>0-3 Miles</u>	<u>Over 3 Miles</u>	
\$9,000.00	\$29,700.00	\$34,160.00	\$7,500.00

- OTU4  
Per Connection

<u>Monthly Rates</u>			<u>Nonrecurring Installation Charge</u>
<u>Within CO</u>	<u>0-3 Miles</u>	<u>Over 3 Miles</u>	
\$9,000.00	\$29,700.00	\$34,160.00	\$7,500.00

FACILITIES FOR INTERSTATE ACCESS

5. Special Access Service (Cont'd)

5.7 Rates and Charges (Cont'd)

5.7.22 Optical Wavelength Service (OWS) (Cont'd)

(A) Channel Termination (Cont'd)

(2) 1 Year

- OC3

Per Connection

<u>Monthly Rates</u>			<u>Nonrecurring Installation Charge</u>
<u>Within CO</u>	<u>0-3 Miles</u>	<u>Over 3 Miles</u>	
\$200.00	\$1,830.00	\$2,105.00	\$3,750.00

- OC12

Per Connection

<u>Monthly Rates</u>			<u>Nonrecurring Installation Charge</u>
<u>Within CO</u>	<u>0-3 Miles</u>	<u>Over 3 Miles</u>	
\$350.00	\$2,135.00	\$2,455.00	\$3,750.00

- OC48

Per Connection

<u>Monthly Rates</u>			<u>Nonrecurring Installation Charge</u>
<u>Within CO</u>	<u>0-3 Miles</u>	<u>Over 3 Miles</u>	
\$750.00	\$3,950.00	\$4,545.00	\$3,750.00

FACILITIES FOR INTERSTATE ACCESS

5. Special Access Service (Cont'd)

5.7 Rates and Charges (Cont'd)

5.7.22 Optical Wavelength Service (OWS) (Cont'd)

(A) Channel Termination (Cont'd)

(2) 1 Year (Cont'd)

- OC192  
Per Connection

<u>Monthly Rates</u>			<u>Nonrecurring Installation Charge</u>
<u>Within CO</u>	<u>0-3 Miles</u>	<u>Over 3 Miles</u>	
\$1,500.00	\$4,950.00	\$5,695.00	\$3,750.00

- Gigabit Ethernet  
Per Connection

<u>Monthly Rates</u>			<u>Nonrecurring Installation Charge</u>
<u>Within CO</u>	<u>0-3 Miles</u>	<u>Over 3 Miles</u>	
\$500.00	\$3,050.00	\$3,510.00	\$3,750.00

- 10 G LAN  
Per Connection

<u>Monthly Rates</u>			<u>Nonrecurring Installation Charge</u>
<u>Within CO</u>	<u>0-3 Miles</u>	<u>Over 3 Miles</u>	
\$1,500.00	\$4,950.00	\$5,695.00	\$3,750.00

FACILITIES FOR INTERSTATE ACCESS

5. Special Access Service (Cont'd)

5.7 Rates and Charges (Cont'd)

5.7.22 Optical Wavelength Service (OWS) (Cont'd)

(A) Channel Termination (Cont'd)

(2) 1 Year (Cont'd)

- 10 GB WAN  
Per Connection

<u>Monthly Rates</u>			<u>Nonrecurring Installation Charge</u>
<u>Within CO</u>	<u>0-3 Miles</u>	<u>Over 3 Miles</u>	
\$1,500.00	\$4,950.00	\$5,695.00	\$3,750.00

- OTU1  
Per Connection

<u>Monthly Rates</u>			<u>Nonrecurring Installation Charge</u>
<u>Within CO</u>	<u>0-3 Miles</u>	<u>Over 3 Miles</u>	
\$750.00	\$3,950.00	\$4,545.00	\$3,750.00

- OTU2  
Per Connection

<u>Monthly Rates</u>			<u>Nonrecurring Installation Charge</u>
<u>Within CO</u>	<u>0-3 Miles</u>	<u>Over 3 Miles</u>	
\$1,500.00	\$4,950.00	\$5,695.00	\$3,750.00

FACILITIES FOR INTERSTATE ACCESS

5. Special Access Service (Cont'd)

5.7 Rates and Charges (Cont'd)

5.7.22 Optical Wavelength Service (OWS) (Cont'd)

(A) Channel Termination (Cont'd)

(2) 1 Year (Cont'd)

- OTU3  
Per Connection

<u>Monthly Rates</u>			<u>Nonrecurring Installation Charge</u>
<u>Within CO</u>	<u>0-3 Miles</u>	<u>Over 3 Miles</u>	
\$3,750.00	\$16,375.00	\$18,835.00	\$3,750.00

- 100 GB Ethernet  
Per Connection

<u>Monthly Rates</u>			<u>Nonrecurring Installation Charge</u>
<u>Within CO</u>	<u>0-3 Miles</u>	<u>Over 3 Miles</u>	
\$7,500.00	\$24,750.00	\$28,465.00	\$3,750.00

- OTU4  
Per Connection

<u>Monthly Rates</u>			<u>Nonrecurring Installation Charge</u>
<u>Within CO</u>	<u>0-3 Miles</u>	<u>Over 3 Miles</u>	
\$7,500.00	\$24,750.00	\$28,465.00	\$3,750.00

FACILITIES FOR INTERSTATE ACCESS

5. Special Access Service (Cont'd)

5.7 Rates and Charges (Cont'd)

5.7.22 Optical Wavelength Service (OWS) (Cont'd)

(A) Channel Termination (Cont'd)

(3) 3 Year

- OC3

Per Connection

<u>Monthly Rates</u>			<u>Nonrecurring Installation Charge</u>
<u>Within CO</u>	<u>0-3 Miles</u>	<u>Over 3 Miles</u>	
\$145.00	\$1,335.00	\$1,535.00	\$1,875.00

- OC12

Per Connection

<u>Monthly Rates</u>			<u>Nonrecurring Installation Charge</u>
<u>Within CO</u>	<u>0-3 Miles</u>	<u>Over 3 Miles</u>	
\$255.00	\$1,555.00	\$1,790.00	\$1,875.00

- OC48

Per Connection

<u>Monthly Rates</u>			<u>Nonrecurring Installation Charge</u>
<u>Within CO</u>	<u>0-3 Miles</u>	<u>Over 3 Miles</u>	
\$545.00	\$2,880.00	\$3,315.00	\$1,875.00

FACILITIES FOR INTERSTATE ACCESS

5. Special Access Service (Cont'd)

5.7 Rates and Charges (Cont'd)

5.7.22 Optical Wavelength Service (OWS) (Cont'd)

(A) Channel Termination (Cont'd)

(3) 3 Year (Cont'd)

- OC192  
Per Connection

<u>Monthly Rates</u>			<u>Nonrecurring Installation Charge</u>
<u>Within CO</u>	<u>0-3 Miles</u>	<u>Over 3 Miles</u>	
\$1,085.00	\$3,600.00	\$4,140.00	\$1,875.00

- Gigabit Ethernet  
Per Connection

<u>Monthly Rates</u>			<u>Nonrecurring Installation Charge</u>
<u>Within CO</u>	<u>0-3 Miles</u>	<u>Over 3 Miles</u>	
\$365.00	\$2,220.00	\$2,555.00	\$1,875.00

- 10 G LAN  
Per Connection

<u>Monthly Rates</u>			<u>Nonrecurring Installation Charge</u>
<u>Within CO</u>	<u>0-3 Miles</u>	<u>Over 3 Miles</u>	
\$1,085.00	\$3,600.00	\$4,140.00	\$1,875.00



FACILITIES FOR INTERSTATE ACCESS

5. Special Access Service (Cont'd)

5.7 Rates and Charges (Cont'd)

5.7.22 Optical Wavelength Service (OWS) (Cont'd)

(A) Channel Termination (Cont'd)

(3) 3 Year (Cont'd)

- 10 G WAN  
Per Connection

<u>Monthly Rates</u>			<u>Nonrecurring Installation Charge</u>
<u>Within CO</u>	<u>0-3 Miles</u>	<u>Over 3 Miles</u>	
\$1,085.00	\$3,600.00	\$4,140.00	\$1,875.00

- OTU1  
Per Connection

<u>Monthly Rates</u>			<u>Nonrecurring Installation Charge</u>
<u>Within CO</u>	<u>0-3 Miles</u>	<u>Over 3 Miles</u>	
\$545.00	\$2,880.00	\$3,315.00	\$1,875.00

- OTU2  
Per Connection

<u>Monthly Rates</u>			<u>Nonrecurring Installation Charge</u>
<u>Within CO</u>	<u>0-3 Miles</u>	<u>Over 3 Miles</u>	
\$1,085.00	\$3,600.00	\$4,140.00	\$1,875.00

FACILITIES FOR INTERSTATE ACCESS

5. Special Access Service (Cont'd)

5.7 Rates and Charges (Cont'd)

5.7.22 Optical Wavelength Service (OWS) (Cont'd)

(A) Channel Termination (Cont'd)

(3) 3 Year (Cont'd)

- OTU3  
Per Connection

<u>Monthly Rates</u>			<u>Nonrecurring Installation Charge</u>
<u>Within CO</u>	<u>0-3 Miles</u>	<u>Over 3 Miles</u>	
\$2,710.00	\$11,860.00	\$13,640.00	\$1,875.00

- 100 Gb Ethernet  
Per Connection

<u>Monthly Rates</u>			<u>Nonrecurring Installation Charge</u>
<u>Within CO</u>	<u>0-3 Miles</u>	<u>Over 3 Miles</u>	
\$5,420.00	\$17,885.00	\$20,565.00	\$1,875.00

- OTU4  
Per Connection

<u>Monthly Rates</u>			<u>Nonrecurring Installation Charge</u>
<u>Within CO</u>	<u>0-3 Miles</u>	<u>Over 3 Miles</u>	
\$5,420.00	\$17,885.00	\$20,565.00	\$1,875.00

FACILITIES FOR INTERSTATE ACCESS

5. Special Access Service (Cont'd)

5.7 Rates and Charges (Cont'd)

5.7.22 Optical Wavelength Service (OWS) (Cont'd)

(A) Channel Termination (Cont'd)

(4) 5 Year

- OC3

Per Connection

<u>Monthly Rates</u>			<u>Nonrecurring Installation Charge</u>
<u>Within CO</u>	<u>0-3 Miles</u>	<u>Over 3 Miles</u>	
\$125.00	\$1,185.00	\$1,280.00	\$0.00

- OC12

Per Connection

<u>Monthly Rates</u>			<u>Nonrecurring Installation Charge</u>
<u>Within CO</u>	<u>0-3 Miles</u>	<u>Over 3 Miles</u>	
\$215.00	\$1,300.00	\$1,495.00	\$0.00

- OC48

Per Connection

<u>Monthly Rates</u>			<u>Nonrecurring Installation Charge</u>
<u>Within CO</u>	<u>0-3 Miles</u>	<u>Over 3 Miles</u>	
\$465.00	\$2,400.00	\$2,760.00	\$0.00

FACILITIES FOR INTERSTATE ACCESS

5. Special Access Service (Cont'd)

5.7 Rates and Charges (Cont'd)

5.7.22 Optical Wavelength Service (OWS) (Cont'd)

(A) Channel Termination (Cont'd)

(4) 5 Year (Cont'd)

- OC192  
Per Connection

<u>Monthly Rates</u>			<u>Nonrecurring Installation Charge</u>
<u>Within CO</u>	<u>0-3 Miles</u>	<u>Over 3 Miles</u>	
\$925.00	\$2,995.00	\$3,445.00	\$0.00

- Gigabit Ethernet  
Per Connection

<u>Monthly Rates</u>			<u>Nonrecurring Installation Charge</u>
<u>Within CO</u>	<u>0-3 Miles</u>	<u>Over 3 Miles</u>	
\$310.00	\$1,855.00	\$2,135.00	\$0.00

- 10 G LAN  
Per Connection

<u>Monthly Rates</u>			<u>Nonrecurring Installation Charge</u>
<u>Within CO</u>	<u>0-3 Miles</u>	<u>Over 3 Miles</u>	
\$925.00	\$2,995.00	\$3,445.00	\$0.00

FACILITIES FOR INTERSTATE ACCESS

5. Special Access Service (Cont'd)

5.7 Rates and Charges (Cont'd)

5.7.22 Optical Wavelength Service (OWS) (Cont'd)

(A) Channel Termination (Cont'd)

(4) 5 Year (Cont'd)

- 10 G WAN  
Per Connection

<u>Monthly Rates</u>			<u>Nonrecurring Installation Charge</u>
<u>Within CO</u>	<u>0-3 Miles</u>	<u>Over 3 Miles</u>	
\$925.00	\$2,995.00	\$3,445.00	\$0.00

- OTU1  
Per Connection

<u>Monthly Rates</u>			<u>Nonrecurring Installation Charge</u>
<u>Within CO</u>	<u>0-3 Miles</u>	<u>Over 3 Miles</u>	
\$465.00	\$2,400.00	\$2,760.00	\$0.00

- OTU2  
Per Connection

<u>Monthly Rates</u>			<u>Nonrecurring Installation Charge</u>
<u>Within CO</u>	<u>0-3 Miles</u>	<u>Over 3 Miles</u>	
\$925.00	\$2,995.00	\$3,445.00	\$0.00

FACILITIES FOR INTERSTATE ACCESS

5. Special Access Service (Cont'd)

5.7 Rates and Charges (Cont'd)

5.7.22 Optical Wavelength Service (OWS) (Cont'd)

(A) Channel Termination (Cont'd)

(4) 5 Year (Cont'd)

- OTU3  
Per Connection

<u>Monthly Rates</u>			<u>Nonrecurring Installation Charge</u>
<u>Within CO</u>	<u>0-3 Miles</u>	<u>Over 3 Miles</u>	
\$2,305.00	\$9,870.00	\$11,355.00	\$0.00

- 100 Gb Ethernet  
Per Connection

<u>Monthly Rates</u>			<u>Nonrecurring Installation Charge</u>
<u>Within CO</u>	<u>0-3 Miles</u>	<u>Over 3 Miles</u>	
\$4,605.00	\$14,310.00	\$16,455.00	\$0.00

- OTU4  
Per Connection

<u>Monthly Rates</u>			<u>Nonrecurring Installation Charge</u>
<u>Within CO</u>	<u>0-3 Miles</u>	<u>Over 3 Miles</u>	
\$4,605.00	\$14,310.00	\$16,455.00	\$0.00

FACILITIES FOR INTERSTATE ACCESS

5. Special Access Service (Cont'd)

5.7 Rates and Charges (Cont'd)

5.7.22 Optical Wavelength Service (OWS) (Cont'd)

(B) Channel Mileage

(1) Month-to-Month

- OC3

Monthly Rates

---

<u>Termination</u>	<u>Facility (Per Mile)</u>
\$240.00	\$5.00

- OC12

Monthly Rates

---

<u>Termination</u>	<u>Facility (Per Mile)</u>
\$420.00	\$10.00

- OC48

Monthly Rates

---

<u>Termination</u>	<u>Facility (Per Mile)</u>
\$900.00	\$25.00

FACILITIES FOR INTERSTATE ACCESS

5. Special Access Service (Cont'd)

5.7 Rates and Charges (Cont'd)

5.7.22 Optical Wavelength Service (OWS) (Cont'd)

(B) Channel Mileage (Cont'd)

(1) Month-to-Month (Cont'd)

- OC192

Monthly Rates

---

<u>Termination</u>	<u>Facility (Per Mile)</u>
\$1,200.00	\$60.00

- Gigabit Ethernet

Monthly Rates

---

<u>Termination</u>	<u>Facility (Per Mile)</u>
\$600.00	\$15.00

- 10 G LAN

Monthly Rates

---

<u>Termination</u>	<u>Facility (Per Mile)</u>
\$1,200.00	\$60.00



FACILITIES FOR INTERSTATE ACCESS

5. Special Access Service (Cont'd)

5.7 Rates and Charges (Cont'd)

5.7.22 Optical Wavelength Service (OWS) (Cont'd)

(B) Channel Mileage (Cont'd)

(1) Month-to-Month (Cont'd)

- 10 G WAN

Monthly Rates

---

<u>Termination</u>	<u>Facility (Per Mile)</u>
\$1,200.00	\$60.00

- OTU1

Monthly Rates

---

<u>Termination</u>	<u>Facility (Per Mile)</u>
\$900.00	\$25.00

- OTU2

Monthly Rates

---

<u>Termination</u>	<u>Facility (Per Mile)</u>
\$1,200.00	\$60.00

FACILITIES FOR INTERSTATE ACCESS

5. Special Access Service (Cont'd)

5.7 Rates and Charges (Cont'd)

5.7.22 Optical Wavelength Service (OWS) (Cont'd)

(B) Channel Mileage (Cont'd)

(1) Month-to-Month (Cont'd)

- OTU3

Monthly Rates

---

<u>Termination</u>	<u>Facility (Per Mile)</u>
\$1,800.00	\$145.00

- 100 Gb Ethernet

Monthly Rates

---

<u>Termination</u>	<u>Facility (Per Mile)</u>
\$3,000.00	\$340.00

- OTU4

Monthly Rates

---

<u>Termination</u>	<u>Facility (Per Mile)</u>
\$3,000.00	\$340.00

FACILITIES FOR INTERSTATE ACCESS

5. Special Access Service (Cont'd)

5.7 Rates and Charges (Cont'd)

5.7.22 Optical Wavelength Service (OWS) (Cont'd)

(B) Channel Mileage (Cont'd)

(2) 1 Year

- OC3

Monthly Rates

---

<u>Termination</u>	<u>Facility (Per Mile)</u>
\$200.00	\$4.00

- OC12

Monthly Rates

---

<u>Termination</u>	<u>Facility (Per Mile)</u>
\$350.00	\$8.00

- OC48

Monthly Rates

---

<u>Termination</u>	<u>Facility (Per Mile)</u>
\$750.00	\$19.00

FACILITIES FOR INTERSTATE ACCESS

5. Special Access Service (Cont'd)

5.7 Rates and Charges (Cont'd)

5.7.22 Optical Wavelength Service (OWS) (Cont'd)

(B) Channel Mileage (Cont'd)

(2) 1 Year (Cont'd)

- OC192

Monthly Rates

---

<u>Termination</u>	<u>Facility (Per Mile)</u>
\$1,000.00	\$50.00

- Gigabit Ethernet

Monthly Rates

---

<u>Termination</u>	<u>Facility (Per Mile)</u>
\$500.00	\$10.00

- 10 G LAN

Monthly Rates

---

<u>Termination</u>	<u>Facility (Per Mile)</u>
\$1,000.00	\$50.00

FACILITIES FOR INTERSTATE ACCESS

5. Special Access Service (Cont'd)

5.7 Rates and Charges (Cont'd)

5.7.22 Optical Wavelength Service (OWS) (Cont'd)

(B) Channel Mileage (Cont'd)

(2) 1 Year (Cont'd)

- 10 GB WAN

Monthly Rates

---

<u>Termination</u>	<u>Facility (Per Mile)</u>
\$1,000.00	\$50.00

- OTU1

Monthly Rates

---

<u>Termination</u>	<u>Facility (Per Mile)</u>
\$750.00	\$19.00

- OTU2

Monthly Rates

---

<u>Termination</u>	<u>Facility (Per Mile)</u>
\$1,000.00	\$50.00

FACILITIES FOR INTERSTATE ACCESS

5. Special Access Service (Cont'd)

5.7 Rates and Charges (Cont'd)

5.7.22 Optical Wavelength Service (OWS) (Cont'd)

(B) Channel Mileage (Cont'd)

(2) 1 Year (Cont'd)

- OTU3

Monthly Rates

---

<u>Termination</u>	<u>Facility (Per Mile)</u>
\$1,500.00	\$120.00

- 100 Gb Ethernet

Monthly Rates

---

<u>Termination</u>	<u>Facility (Per Mile)</u>
\$2,500.00	\$280.00

- OTU4

Monthly Rates

---

<u>Termination</u>	<u>Facility (Per Mile)</u>
\$2,500.00	\$280.00

FACILITIES FOR INTERSTATE ACCESS

5. Special Access Service (Cont'd)

5.7 Rates and Charges (Cont'd)

5.7.22 Optical Wavelength Service (OWS) (Cont'd)

(B) Channel Mileage (Cont'd)

(3) 3 Year

- OC3

Monthly Rates

---

<u>Termination</u>	<u>Facility (Per Mile)</u>
\$130.00	\$3.00

- OC12

Monthly Rates

---

<u>Termination</u>	<u>Facility (Per Mile)</u>
\$225.00	\$6.00

- OC48

Monthly Rates

---

<u>Termination</u>	<u>Facility (Per Mile)</u>
\$480.00	\$14.00

FACILITIES FOR INTERSTATE ACCESS

5. Special Access Service (Cont'd)

5.7 Rates and Charges (Cont'd)

5.7.22 Optical Wavelength Service (OWS) (Cont'd)

(B) Channel Mileage (Cont'd)

(3) 3 Year (Cont'd)

- OC192

Monthly Rates

---

<u>Termination</u>	<u>Facility (Per Mile)</u>
\$640.00	\$35.00

- Gigabit Ethernet

Monthly Rates

---

<u>Termination</u>	<u>Facility (Per Mile)</u>
\$320.00	\$7.00

- 10 G LAN

Monthly Rates

---

<u>Termination</u>	<u>Facility (Per Mile)</u>
\$640.00	\$35.00



FACILITIES FOR INTERSTATE ACCESS

5. Special Access Service (Cont'd)

5.7 Rates and Charges (Cont'd)

5.7.22 Optical Wavelength Service (OWS) (Cont'd)

(B) Channel Mileage (Cont'd)

(3) 3 Year (Cont'd)

- 10 G WAN

Monthly Rates

---

<u>Termination</u>	<u>Facility (Per Mile)</u>
\$640.00	\$35.00

- OTU1

Monthly Rates

---

<u>Termination</u>	<u>Facility (Per Mile)</u>
\$480.00	\$14.00

- OTU2

Monthly Rates

---

<u>Termination</u>	<u>Facility (Per Mile)</u>
\$640.00	\$35.00

## FACILITIES FOR INTERSTATE ACCESS

5. Special Access Service (Cont'd)5.7 Rates and Charges (Cont'd)5.7.22 Optical Wavelength Service (OWS) (Cont'd)(B) Channel Mileage (Cont'd)(3) 3 Year (Cont'd)- OTU3

---

Monthly Rates

---

<u>Termination</u>	<u>Facility (Per Mile)</u>
\$960.00	\$90.00

- 100 Gb Ethernet

---

Monthly Rates

---

<u>Termination</u>	<u>Facility (Per Mile)</u>
\$1,600.00	\$210.00

- OTU4

---

Monthly Rates

---

<u>Termination</u>	<u>Facility (Per Mile)</u>
\$1,600.00	\$210.00

FACILITIES FOR INTERSTATE ACCESS

5. Special Access Service (Cont'd)

5.7 Rates and Charges (Cont'd)

5.7.22 Optical Wavelength Service (OWS) (Cont'd)

(B) Channel Mileage (Cont'd)

(4) 5 Year

- OC3

Monthly Rates

---

<u>Termination</u>	<u>Facility (Per Mile)</u>
\$105.00	\$2.25

- OC12

Monthly Rates

---

<u>Termination</u>	<u>Facility (Per Mile)</u>
\$180.00	\$5.00

- OC48

Monthly Rates

---

<u>Termination</u>	<u>Facility (Per Mile)</u>
\$385.00	\$12.00

FACILITIES FOR INTERSTATE ACCESS

5. Special Access Service (Cont'd)

5.7 Rates and Charges (Cont'd)

5.7.22 Optical Wavelength Service (OWS) (Cont'd)

(B) Channel Mileage (Cont'd)

(4) 5 Year (Cont'd)

- OC192

Monthly Rates

---

<u>Termination</u>	<u>Facility (Per Mile)</u>
\$515.00	\$30.00

- Gigabit Ethernet

Monthly Rates

---

<u>Termination</u>	<u>Facility (Per Mile)</u>
\$260.00	\$6.00

- 10 G LAN

Monthly Rates

---

<u>Termination</u>	<u>Facility (Per Mile)</u>
\$515.00	\$30.00

FACILITIES FOR INTERSTATE ACCESS

5. Special Access Service (Cont'd)

5.7 Rates and Charges (Cont'd)

5.7.22 Optical Wavelength Service (OWS) (Cont'd)

(B) Channel Mileage (Cont'd)

(4) 5 Year (Cont'd)

- 10 G WAN

Monthly Rates

---

<u>Termination</u>	<u>Facility (Per Mile)</u>
\$515.00	\$30.00

- OTU1

Monthly Rates

---

<u>Termination</u>	<u>Facility (Per Mile)</u>
\$385.00	\$12.00

- OTU2

Monthly Rates

---

<u>Termination</u>	<u>Facility (Per Mile)</u>
\$515.00	\$30.00

FACILITIES FOR INTERSTATE ACCESS

5. Special Access Service (Cont'd)

5.7 Rates and Charges (Cont'd)

5.7.22 Optical Wavelength Service (OWS) (Cont'd)

(B) Channel Mileage (Cont'd)

(4) 5 Year (Cont'd)

- OTU3

Monthly Rates

---

<u>Termination</u>	<u>Facility (Per Mile)</u>
\$768.00	\$70.00

- 100 Gb Ethernet

Monthly Rates

---

<u>Termination</u>	<u>Facility (Per Mile)</u>
\$1,280.00	\$170.00

- OTU4

Monthly Rates

---

<u>Termination</u>	<u>Facility (Per Mile)</u>
\$1,280.00	\$170.00

5.8 Reserved For Future Use

5.9 Individual Case Basis Rates and Charges

Certain services set forth in Special Access Service, Section 5 are provided on an Individual Case Basis.

## FACILITIES FOR INTERSTATE ACCESS

6. MISCELLANEOUS SERVICES6.1 General

MISCELLANEOUS SERVICES available to the customer include the following:

- (A) Additional Labor (i.e., Overtime Installation, Overtime Repair, Additional Installation Testing, Standby, Testing and Maintenance with Other Telephone Companies)
- (B) Maintenance of Service
- (C) Telecommunications Service Priority (TSP) System
- (D) Additional Testing
- (E) Billing Name and Address Service
- (F) Universal Service Fund Charge
- (G) Provision of Access Service Billing Information

These services are described in detail as set forth in 6.2 through 6.4, 6.6, 6.8, 6.18 and 6.20 following.

## FACILITIES FOR INTERSTATE ACCESS

6. MISCELLANEOUS SERVICES (Cont'd)6.2 Additional Labor

Additional Labor is that labor requested by the customer on a given FIA and agreed to by the Company as set forth in (A) through (F) following. The Company will notify the customer that Additional Labor charges as set forth in (G) following will apply before any Additional Labor is undertaken. Additional Labor charges will also apply if the requirement for the Additional Labor is the fault of the customer or parties on whose behalf it acts.

- (A) Overtime Installation  
Overtime installation is that Company installation effort outside the business day. Overtime rates will apply anytime outside the business day and all day Saturday. Premium time rates will apply all day Sunday and on all Company approved holidays. For applicable holidays in each jurisdiction contact Issuing Carrier identified on Title Pages 2 and 3 preceding.
- (B) Overtime Repair  
Overtime repair is Company repair which could have been performed during the normal business day, but that is delayed at the specific request of the customer to a later time period which is outside the normal business day or to a weekend day or holiday. The request will result in the application of overtime rates anytime outside the business day and all day Saturday. Premium time rates will apply on Sunday and Company approved holidays. These rates, as set forth in Section 6.2 following, will only apply when there is a delay of repair at the request of the customer to the time periods stated above.
- (C) Additional Installation Testing  
Additional installation testing is that testing performed by the Company at the time of installation which is in addition to normal pre-service and acceptance testing.
- (D) Standby  
Standby includes all time in excess of one-half (1/2) hour during which Company personnel are available to make coordinated tests on a given FIA. The standby charge applies only when Company personnel must wait more than 30 minutes beyond a prearranged, mutually agreed appointment time. Standby charges will cease when testing begins, or when Company personnel are released from the standby requirement, or when testing is rescheduled for a later date or time. Charges will not be applicable if Company personnel cause the delay.
- (E) Testing and Maintenance with Other Telephone Companies  
Additional testing, maintenance, or repair of facilities which connect to facilities of other telephone companies, which is in addition to normal effort required to test, maintain, or repair facilities provided solely by the Company.
- (F) Other Labor  
Other labor is that additional labor not included in (A) through (E) preceding, and labor incurred to accommodate a specific customer request that involves only labor which is not covered by any other section of this Service guide.



FACILITIES FOR INTERSTATE ACCESS

6. MISCELLANEOUS SERVICES (Cont'd)

6.2 Additional Labor (Cont'd)

(F) Charges for Additional Labor

<u>Jurisdiction</u>	<u>Labor Periods</u>	
	<u>Basic Time, Business Day, Per Technician</u>	
	<u>First Half Hour or Fraction Thereof</u>	<u>Each Additional Half Hour or Fraction Thereof</u>
Alabama	\$42.67	\$29.33
Missouri	42.67	29.33
<u>Jurisdiction</u>	<u>Overtime, Outside the Business Day, Per Technician*</u>	
	<u>First Half Hour or Fraction Thereof</u>	<u>Each Additional Half Hour or Fraction Thereof</u>
	Alabama	\$100.00
Missouri	100.00	75.00
<u>Jurisdiction</u>	<u>Premium Time, Outside the Business Day, Per Technician*</u>	
	<u>First Half Hour or Fraction Thereof</u>	<u>Each Additional Half Hour or Fraction Thereof</u>
	Alabama	\$150.00
Missouri	150.00	125.00

\* A call out of a Company employee at a time not consecutive with the business day is subject to a minimum charge of four hours.

## FACILITIES FOR INTERSTATE ACCESS

6. MISCELLANEOUS SERVICES (Cont'd)6.3 Maintenance of Service Charge

- (A) When a customer reports trouble to the Company for clearance, the customer shall be responsible for payment of a Maintenance of Service Charge when Company personnel are dispatched to the customer's location and no trouble is found in the Company's facilities. Failure of Company personnel to find trouble in Company facilities will result in no charge if the trouble is actually in those facilities, but not discovered at the time.

In this case, or in (B) following, no credit allowance will be applicable for the interruption involved, unless the trouble is found in the Company's facilities.

- (B) The customer shall be responsible for payment of a Maintenance of Service Charge when the Company dispatches personnel to the customer's location and the trouble is in equipment or communications systems provided by other than the Company or in detariffed CPE provided by the Company.
- (C) The Maintenance of Service Charge time period will begin when Company personnel are dispatched. This will only include the actual time required to reach the customer's location and perform an investigation. The time period will end when the investigation is finished. The labor charge as set forth in 6.2 (G) preceding will apply to Maintenance of Service at the appropriate Basic, Overtime or Premium rate. These charges apply whether the trouble is in the equipment of communications systems provided by other than the Company, or in detariffed CPE provided by the Company.

## FACILITIES FOR INTERSTATE ACCESS

6. MISCELLANEOUS SERVICES (Cont'd)6.4 Telecommunications Service Priority (TSP) System(A) Description of the Service

The TSP System is a service that provides for the priority provisioning and/or restoration of National Security Emergency Preparedness (NSEP) telecommunications services. The TSP System applies only to NSEP services, includes both Switched and Special FIA and provides the Company with a guide to the sequence in which services are to be provisioned and/or restored.

The Company currently has Special Access circuits classified as RP (Restoration Priority). These facilities were offered under part 64.401, Subpart D, Appendix A of the FCC Rules and Regulations prior to the revisions released November 17, 1988 under GEN. Docket No. 87-505 (FCC 88-341). These facilities will maintain their RP designation and priority treatment until either converted by the customer to the TSP System, or until March 10, 1993, whichever occurs first.

All FIA that can be identified by a unique circuit identifier can be provisioned for NSEP service by the Company.

The rates and charges associated with a customer subscribing to the TSP System are as specified in Section 6.4(G).

(B) Obtaining TSP System Service

The Executive Office of the President through the TSP Program Office, is empowered with the authority to receive, evaluate and process requests for NSEP services. The TSP Program Office makes the priority level assignments and issues the TSP authorization code reflecting the priority assignment associated with a request. The customer provides the TSP authorization code, in addition to all the other details necessary to complete the order (ASR) to the Company to obtain TSP System service.

The TSP authorization code, assigned on a per ASR basis, consists of a 12-character field consisting of a nine-character control ID followed by a dash and a two-character field specifying the priority level assignment. Its structure is as follows:

TSPxxxxxn-yy

The "x"s represent a sequence of numbers unique to each TSP authorization code and the "n" is a one character alphanumeric check digit. The first "y" contains the provisioning priority level assignment and the second "y" contains the restoration priority level assignment.

## FACILITIES FOR INTERSTATE ACCESS

6. MISCELLANEOUS SERVICES (Cont'd)6.4 Telecommunications Service Priority (TSP) System (Cont'd)(C) Provisioning Priority

If the customer requires service within a shorter time interval than the Company can provide, and the requested service qualifies for NSEP, the customer may elect to invoke NSEP Treatment and obtain the appropriate provisioning priority assignment from the TSP Program Office. Acceptable assignment code values are: E, 1, 2, 3, 4, 5 or 0.

The assignment of the value "E" denotes Emergency Provisioning and implies the service has the most critical provisioning requirements and the Company will respond accordingly. The Company will take immediate action to provide the requested service at the earliest possible date. Rates and charges associated with "E" provisioning are as specified in Section 6.4(G)(2)(a).

The assignment values of 1, 2, 3, 4 and 5 are treated as essential service priorities and the Company will adjust its available resources to meet the customer's requested due date. Rates and charges associated with invoking this priority treatment are specified in Section 6.4(G)(2)(b). The value "0" implies no provisioning priority.

(D) Restoration Priority

A TSP authorization code for restoration priority classifies the service as being among the nation's most important NSEP telecommunications services. The Company will restore these services before services without restoration priority assignments in the order of priority assignments. Acceptable values are: 1, 2, 3, 4, 5 or 0 with the value "1" being the highest priority.

When the Company recognizes a TSP as being out of service, unusable or receives a trouble report, available resources will be dispatched to restore the service as quickly as practicable. A priority value of 1, 2 or 3 requires dispatch outside normal business hours if necessary to restore the service. A priority value of 4 or 5 only requires dispatch outside of normal business hours if the next business day is more than 24 hours away. If the value "0" has been assigned, then no restoration priority is applicable to this service.

The minimum period for service is one month.

## FACILITIES FOR INTERSTATE ACCESS

6. MISCELLANEOUS SERVICES (Cont'd)6.4 Telecommunications Service Priority (TSP) System (Cont'd)(E) Obligations of the Customer

- (1) In all instances, the customer is responsible for obtaining the appropriate TSP authorization code and providing that code to the Company.
- (2) The TSP System service customer must also be the customer for the FIA with which TSP service is associated. Only the customer or its authorized agent as indicated in a letter of agency on file with the Company is allowed to order TSP System service.
- (3) All points of a multipoint service configuration must have the same restoration priority assignment and must satisfy the requirements of that assignment.
- (4) In obtaining TSP System service, the customer consents to the release of certain information by the Company to the federal government in order to maintain and administer the TSP System. Such information includes: the customer's name, telephone number and mailing address, the TSP authorization code and the circuit or service ID number associated with the NSEP service.
- (5) The Company will attempt to notify the customer of expected charges. The customer when invoking NSEP Treatment, recognizes that quoting charges and obtaining permission beforehand may not be practicable and may cause unnecessary delays and, as a result, grants the Company the right to quote and bill charges after provisioning of the service.
- (6) During certain emergencies, the customer may request TSP assignments verbally and the Company will accept such verbal notification. The customer must submit a written order (ASR) to the Company within two working days following the verbal request. If the written order (ASR) is not received within two working days, all applicable rates and charges accumulated to date to provision TSP System service, become immediately due and payable and the requested TSP priority is revoked.
- (7) The customer must request and justify revalidation of all priority level assignments at least every three years.
- (8) Additionally, the NCS Manual 3-1-1, "Telecommunications Service Priority (TSP) System for National Security Emergency Preparedness (NSEP) Service User Manual", dated July 9, 1990 prescribes specific conditions which warrant NSEP Treatment and related procedures.

## FACILITIES FOR INTERSTATE ACCESS

6. MISCELLANEOUS SERVICES (Cont'd)6.4 Telecommunications Service Priority (TSP) System (Cont'd)(F) Obligations of the Company

- (1) The Company will allocate resources to ensure best efforts to provide NSEP services by the time required.
- (2) The Company will work TSP System services in the order of their priority level assignments. The priority sequence is as follows:
  - Restore NSEP services assigned restoration priority 1
  - Provision Emergency (E) NSEP services
  - Restore NSEP services assigned restoration priority 2, 3, 4 or 5
  - Provision NSEP services assigned provisioning priority 1, 2, 3, 4 or 5.
- (3) The Company will work cooperatively with other providers of NSEP service when only a portion is provided by the Company to ensure "end-to-end" service.
- (4) Additionally, TSP System service will be provided in accordance with the guidelines set forth in NCS Handbook 3-1-2, "Telecommunications Service Priority (TSP) System for National Security Emergency Preparedness (NSEP) Service Vendor Handbook" dated July 9, 1990.

(G) Rates and Charges

The following rates and charges are in addition to all other rates and charges that may apply for other services offered under this service guide which operate in conjunction with the TSP System.

(1) Establishment of TSP System Service

The establishment of TSP System service charge is a nonrecurring charge (NRC) specified in Section 6.4(G)(4) which applies when a FIA is ordered with provisioning and/or restoration priority. If both are ordered at the same time, only one NRC is applicable. The NRC is also applicable for orders changing priority levels.

## FACILITIES FOR INTERSTATE ACCESS

6. MISCELLANEOUS SERVICES (Cont'd)6.4 Telecommunications Service Priority (TSP) System (Cont'd)(G) Rates and Charges (Cont'd)(2) Provisioning Priority

There are two basic levels of priority provisioning, Emergency (provisioning priority "E") and Essential (provisioning priority 1, 2, 3, 4 or 5).

(a) Emergency Provisioning

The Company will take immediate action to provide the requested service at the earliest possible date. The rates and charges will apply as set forth in Brightspeed Local Operating Companies Tariff F.C.C. No. 5, Special Construction.

(b) Essential Provisioning

The Company will adjust its available resources to meet the customers requested due date. The rates and charges will apply as set forth in Section 3.2.2(E).

(3) Restoration Priority

Restoration Priority is a monthly rate per circuit for the ongoing administration and maintenance of the TSP System, rates are specified in Section 6.4(G).

FACILITIES FOR INTERSTATE ACCESS

6. MISCELLANEOUS SERVICES (Cont'd)

6.4 Telecommunications Service Priority (TSP) System (Cont'd)

(G) Rates and Charges (Cont'd)

(4) Establishment of TSP System Service Charge

<u>Jurisdiction</u>	Nonrecurring Charge <u>Per Circuit</u>
Alabama	\$14.50
Missouri	14.50

(5) Restoration Priority Rates

<u>Jurisdiction</u>	Monthly Rates <u>Per Circuit</u>
Alabama	\$4.85
Missouri	4.85



## FACILITIES FOR INTERSTATE ACCESS

6. MISCELLANEOUS SERVICES (Cont'd)6.5 Reserved For Future Use6.6 Additional Testing

The Company will perform acceptance testing as specified in 5.1.5 preceding to insure that FIA ordered by the customer are functioning properly, prior to turning over such FIA to the customer.

Testing offered under this section of the service guide is in addition to those tests described above and will be provided, when requested by the customer, at an additional charge.

Testing is provided by Company personnel at Company locations. However, provisions are made in 6.6(A)(5) and 6.6(B)(2) following, to allow a customer to request Company personnel to perform testing at the customer designated location or the end user premises.

Additional testing is provided on a scheduled or nonscheduled basis. Scheduled testing shall be performed on a predetermined time basis to allow for cost efficient utilization of Company and customer resources. Scheduled testing should be based on a one year period. Nonscheduled tests are performed by the Company on a request-by-request basis, not in conjunction with any fixed schedule.

The offering of testing under this section of the service guide is made subject to the availability of the necessary qualified personnel and test equipment at the various test locations mentioned in (A), (B), and (C) following.

## FACILITIES FOR INTERSTATE ACCESS

6. MISCELLANEOUS SERVICES (Cont'd)6.6 Additional Testing (Cont'd)(A) Special Access Testing

The Company will, at the request of a customer, provide assistance in performing specific tests requested by the customer, however, the Company will only perform maintenance testing for its facilities within the LATA.

(1) Additional Cooperative Acceptance Testing

When a customer provides a technician at its customer designated location or at the end user premises, with suitable test equipment to perform the required tests, the Company will provide a technician at its office for the purpose of conducting Additional Cooperative Acceptance Testing (ACAT). The labor charges as set forth in 6.2(G) preceding will apply to ACAT at the appropriate Basic, Overtime, or Premium rate.

Additional Cooperative Acceptance Testing charges will apply when the customer requests tests which are not required to meet the transmission performance parameters as set forth in the GTE Technical Interface Reference Manual.

(2) Nonscheduled Testing

When a customer provides a technician at its customer designated location or at the end user premises, with suitable test equipment to perform the required tests, the Company will provide a technician at its office (cooperative testing) for the purpose of conducting Nonscheduled Testing (NST). Nonscheduled testing may consist of any test which the customer may request. If such testing indicates trouble in Company facilities, then the customer will not be charged. NST charges will apply if the trouble is in the facilities of the customer. At the customer's request, the Company will provide a technician at the customer designated location or at the end user premises (manual testing). The labor charges as set forth in 6.2(G) preceding will apply to Nonscheduled Testing at the appropriate Basic, Overtime, or Premium rate.

(3) Obligation of the Customer

When the customer the customer shall make the facilities to be tested available to the Company at times mutually agreed upon.

6.7 Reserved For Future Use

## FACILITIES FOR INTERSTATE ACCESS

6. MISCELLANEOUS SERVICES (Cont'd)6.8 Billing Name and Address Services (BNAS)

The Company will, upon request, provide Billing Name and Address Services (BNAS) to a Telecommunications Service Provider (customer), or its authorized billing and collection agent. Telecommunications Service Providers include interexchange carriers, operator service providers, enhanced service providers, and any other provider of interstate telecommunications services. There are three BNAS offerings available pursuant to this service guide, Per Call/Periodic BNA, Data Gathering Service (DGS), and End User Validation List.

(A) Per Call/Periodic BNA and Data Gathering Service

Per Call/Periodic BNA is the billing name and address information and Data Gathering is the billing telephone number, name, address and associated working telephone number information for customer provided ten digit end user telephone numbers required by the Telecommunications Service Provider customer to bill for calls placed within a specific time period. Per Call/Periodic BNA and DGS are offered subject to the conditions set forth in the following:

- (1) A standard format for the receipt and provision of telephone number and billing name and address information will be established by the Company. Charges for each Per Call/Periodic BNA searched for and found or searched for and not found will be billed at rates in 6.8.1(A). Charges for each record accessed for DGS are set forth under 6.8.1(B). Per Call/Periodic BNA and DGS will be provided via electronic transmission or paper format, at the option of the customer, at rates in 6.8.1. The processing fee will be applied on a per state basis, once per calendar year for BNAS processing done within that calendar year.
- (2) The customer must order Per Call/Periodic BNA or DGS and provide test data tape at least 30 days prior to delivery of the first customer order.
- (3) The frequency for receipt of the customer provided orders for Per Call/Periodic BNA or DGS will be no more than twice monthly and at intervals mutually agreed upon between the Company and the customer. The customer provided end user telephone numbers will be programmed by the Company with the proper end user's billing name and address contained in the Company's file at that time.

## FACILITIES FOR INTERSTATE ACCESS

6. MISCELLANEOUS SERVICES (Cont'd)6.8 Billing Name and Address Services (BNAS) (Cont'd)(A) Per Call/Periodic BNA and Data Gathering Service (Cont'd)

- (4) Per Call/Periodic BNA and DGS information for nonlisted/nonpublished end user telephone numbers will be provided unless the nonlisted/nonpublished end user provides notice of nonconsent to the Company of nonconsent to the release of the BNA/DGS data. Within 30 days of receipt of such notice, the Company will discontinue disclosure of the nonlisted/nonpublished BNA/DGS data.
- (5) For other than electronic transmission, the output records will be sent to the customer via first class U. S. Mail. The output records will normally be made available for mailing ten workdays after receipt of the customer order or at an interval mutually agreed upon. Availability may be delayed in case of input errors in the customer provided order.
- (6) The customer may request data be transmitted. Data transmission charges will be determined on an ICB. Data transmission hardware and software specifications will be mutually agreed upon by the Company and the customer.
- (7) Per Call/Periodic BNA and DGS detail will not be retained by the Company longer than 45 days. If the customer requests that the output be made available on a second occasion, such request must occur within 30 days from the date the first was made.
- (8) Any customer, provided Per Call/Periodic BNA or DGS pursuant to this service guide, agrees to abide by all applicable rules, decisions, orders, statutes and laws concerning the disclosure of published and nonpublished telephone numbers, and further agrees to use the information contained therein only for the purpose of billing for services provided to their end users.
- (9) In no case shall any customer or authorized billing and collection agent of a customer disclose the billing name and address information of any subscriber to any third party, except that a customer may disclose BNA/DGS information to its authorized billing and collection agent or to governmental law enforcement agencies.
- (10) Conditions regarding refusal or discontinuance of this service are set forth in 2.1.8.

## FACILITIES FOR INTERSTATE ACCESS

6. MISCELLANEOUS SERVICES (Cont'd)6.8 Billing Name and Address Services (BNAS) (Cont'd)(B) End User Validation List

End User Validation Lists provide for the disclosure of all or a portion of end user/agent data available from the Company's records, to a Telecommunications Service Provider (customer), for purposes other than billing, and in compliance with the conditions set forth in Part 64.1201(c)(1) of the FCC's Rules and Regulations. In addition, End User Validation List Service is offered subject to the conditions set forth in 6.8(A)(9) above, and the following:

- (1) Standard End User Validation Lists will be provided in three (3) files, business, coin (semi-public and public paystations) and residence. Nonlisted/nonpublished information will be excluded, with the exception of nonlisted public paystations. The lists may be ordered on a national, multi-state or state level basis, at the option of the customer, for any of the Company's jurisdictions subject to this service guide, unless prohibited by federal regulation or federal statute. Rates for the standard End User Validation List are set forth under 6.8.1(C).
- (2) Per calendar year, the customer may request up to two (2) lists per state for business, coin, and residence listings.
- (3) A standard format will be established by the Company. Requests for special list sorts will be limited to an end user list separating those that are presubscribed to the requesting customer, and/or those that are not. The rate, per record, applicable to special sorts is set forth under 6.8.1(C).
- (4) Each request shall be treated as a new request. Requests for updates from previous lists will not be provided.
- (5) The customer shall have fifteen (15) business days from the date of delivery of a list to request any investigation of issues arising from the provision of the list.
- (6) End User Validation Lists will normally be provided to the customer within thirty calendar days after receipt of a request and within ten (10) business days of extraction, or at an interval mutually agreed upon. The administrative fee set forth under 6.8.1(C) applies per request, whether ordered on a per state, multi-state, or national level.
- (7) Conditions regarding refusal or discontinuance of this service are set forth in 2.1.8.

FACILITIES FOR INTERSTATE ACCESS

6. MISCELLANEOUS SERVICES (Cont'd)

6.8 Billing Name and Address Services (BNAS) (Cont'd)

6.8.1 Rates and Charges

(A) Per Call/Periodic BNA

	<u>Billing Name and Address Found/Each</u>	<u>Billing Name and Address Not FoundEach</u>	<u>Processing Fee*</u> Paper Report, Electronic Transmission <u>Each State</u>
<u>Jurisdiction</u>			
Alabama	\$.26	\$.25	\$50.00
Missouri	.25	.24	50.00

(B) Data Gathering Service

	<u>Per Record Accessed</u>	<u>Processing Fee*</u> Paper Report, Electronic Transmission <u>Each State</u>
<u>Jurisdiction</u>		
Alabama	\$.18	\$75.00
Missouri	.17	75.00

\* Applies once per calendar year for BNA processing done within that calendar year.

FACILITIES FOR INTERSTATE ACCESS

6. MISCELLANEOUS SERVICES (Cont'd)

6.8 Billing Name and Address Services (BNAS) (Cont'd)

6.8.1 Rates and Charges (Cont'd)

(C) End User Validation List

<u>Jurisdiction</u>	<u>Standard Sort, Per Record Provided</u>	<u>Administrative Fee Paper Report, Electronic Transmission Per Request</u>	<u>Special Sort, Per Record Provided</u>
Alabama	\$.034	\$78.00	\$.054
Missouri	.034	78.00	.054

6.9 – 6.17 Reserved For Future Use

## FACILITIES FOR INTERSTATE ACCESS

6. MISCELLANEOUS SERVICES (Cont'd)6.18 Universal Service Fund Charge

The Federal Universal Service Charge (FUSC) recovers the Company's contribution to various federal universal service funds. The Company will apply the FUSC Surcharge Factor each month to the billed charges for interstate access services provided to end users from this service guide.

The FUSC Surcharge Factor will not apply to any billed charges for an end user when the interstate access provided to the end user qualifies under the federal universal service guidelines for the Lifeline Assistance Program. The FUSC Surcharge Factor will not apply to interstate access services purchased by customers that resell these services to end users as part of an interstate telecommunications service and are required to contribute to the various federal universal service funds. In case of a dispute regarding whether the customer is reselling services and contributing to the various federal universal service funds, the Company may request a signed certification to that effect from the customer.

The FCC Contribution factor is subject to change quarterly. The current factor can be found at:

<http://www.fcc.gov/encyclopedia/contribution-factor-quarterly-filings-universal-service-fund-usf-management-support>

6.19 Reserved For Future Use



## FACILITIES FOR INTERSTATE ACCESS

6. MISCELLANEOUS SERVICES (Cont'd)6.20 Provision of Access Service Billing Information

- (A) The customer shall select the medium in which its official access service bills and customer service records are to be provided. This selection shall be made on a per Billing Account Number (BAN) basis and shall be submitted in writing to the Telephone Company. The customer may request that access service billing information be provided via electronic data transfer, on-line bill image, or paper format. Should the customer fail to make a selection, the official copy of the customer's access service bills and customer service records will be provided in paper format. If a customer requests their access bill in multiple formats that includes the paper format, the paper format will be considered the additional or secondary format and will be charged according to 6.20(E).
- (B) At the customer's option, additional copies of the current month's access service bill and/or customer service records will be provided via paper format at the charges specified in 6.20(E) following. Requests for additional copies of the current month's bill and/or customer service records must be submitted in writing and shall specify the medium selected by the customer.

Additional copies of a customer's previous monthly access service bills will be provided via paper format on an individual case basis. Requests for additional copies of previous monthly bills must be submitted in writing and shall specify the bill dates requested and the medium in which the copies are to be provided. The charges for providing additional copies of previous monthly access service bills will be developed by the Telephone Company on an individual case basis.

## FACILITIES FOR INTERSTATE ACCESS

6. MISCELLANEOUS SERVICES (Cont'd)6.20 Provision of Access Service Billing Information (Cont'd)

- (C) Upon acceptance by the Telephone Company of an order for electronic data transfer, the Telephone Company will determine the period of time to implement the transmission of such material on an individual order basis.
- (D) Upon acceptance of an order by the Telephone Company for the on-line bill image format option, the Telephone Company will establish customer access to the Billing Account Number identified by the customer. The on-line bill image option captures and retains invoices on a go-forward basis from the time of initial set-up. Previous bill history will not be available in the on-line bill image format prior to the establishment of the on-line bill image format option by the customer.

The rates and charges for the provision of Access Service Billing Information for other additional or secondary formats are as specified in 6.20(E) following.

FACILITIES FOR INTERSTATE ACCESS

6. MISCELLANEOUS SERVICES (Cont'd)

6.20 Provision of Access Service Billing Information (Cont'd)

(E) Additional copies of the customer's monthly bill

- per copy per Billing Account Number in paper format

<u>Monthly Rate</u>	<u>Non-Recurring Charge</u>
-------------------------	---------------------------------

\$60.00	\$60.00
---------	---------

## FACILITIES FOR INTERSTATE ACCESS

7. SPECIALIZED FIA OR ARRANGEMENTS7.1 General

Specialized FIA or Arrangements may be provided by the Company, at the request of a customer, on an Individual Case Basis (ICB) if such FIA or arrangements meet the following criteria:

- The requested FIA or arrangements are not offered under other sections of this service guide.
- The facilities utilized to provide the requested FIA or arrangements are of a type normally used by the Company in furnishing its other services.
- The requested FIA or arrangements are provided within a Market Area.
- The requested FIA or arrangements are compatible with other Company services, facilities, and its engineering and maintenance practices.

This offering is subject to the availability of the necessary Company personnel and capital resources.

Rates and charges and additional regulations if applicable, for Specialized Service or Arrangements are provided on an Individual Case Basis.

FACILITIES FOR INTERSTATE ACCESS

8. Reserved For Future Use

## FACILITIES FOR INTERSTATE ACCESS

9. SPECIAL FACILITIES ROUTING OF FIA9.1 Description of Special Facilities Routing of FIA

The FIA provided under this service guide are provided over such routes and facilities as the Telephone Company may elect. Special routing is involved where, in order to comply with requirements specified by the customer, the Telephone Company provides Switched Access, Special Access or Special Federal Government Services in a manner which includes one or more of the following conditions.

The rates and charges for Special Facilities Routing of Access Services are developed on an individual case basis, and are in addition to all other rates and charges that may be applicable for services provided under other sections of this service guide.

9.1.1 Diversity

Where two or more FIA must be provided over not less than two different physical routes. Diversity is a Basic Service Element (BSE) under the Company's Open Network Architecture (ONA) plan.

9.1.2 Avoidance

Where a FIA must be provided on a route which avoids specified geographical locations.

FACILITIES FOR INTERSTATE ACCESS

10. Reserved For Future Use

FACILITIES FOR INTERSTATE ACCESS

11. Reserved For Future Use



FACILITIES FOR INTERSTATE ACCESS

12. Reserved For Future Use

FACILITIES FOR INTERSTATE ACCESS

13. Reserved For Future Use

FACILITIES FOR INTERSTATE ACCESS

14. Reserved For Future Use

FACILITIES FOR INTERSTATE ACCESS

15. Reserved For Future Use

FACILITIES FOR INTERSTATE ACCESS

16. Reserved For Future Use

FACILITIES FOR INTERSTATE ACCESS

17. Reserved For Future Use

FACILITIES FOR INTERSTATE ACCESS

18. Reserved For Future Use

FACILITIES FOR INTERSTATE ACCESS

19. Reserved For Future Use



Effective: October 4, 2022

Original Page 20-1

## FACILITIES FOR INTERSTATE ACCESS

20. Optical Networking

Effective December 26, 1998 Dense Wave Division Multiplexing (DWDM) is Grandfathered to existing Customers Only.

Effective March 1, 2022 CUSTOM CONNECT with terms of 36, 60 or 84 months will be grandfathered until the expiration date of the current term. As of this effective date, 36, 60 and 84 month term renewals will not be offered on this plan. Upon expiration of the current term, rates will revert to month-to-month/one year.

CUSTOM CONNECT OC-192 Point-to-Point configurations are grandfathered as of February 11, 2019 and will no longer be available for new service requests. This does not impact CUSTOM CONNECT OC-192 Multipoint or Ring configurations.

20.1 General

This section contains the rules and regulations pertaining to the provisioning of SONET Access and Dense Wave Division Multiplexing (DWDM) Service. The regulations and rates specified herein are in addition to the applicable rates and regulations specified in other Sections of this service guide.

This service supports asynchronous bandwidth capacities at 1.5 Mbps and 45 Mbps in addition to synchronous Optical Carrier (OC) bandwidth capacities at OC-3, OC-3c, OC-12, OC-12c, OC-48, OC48c and OC192 bit rates and 1.25 Gbps or 2.5 Gbps wavelengths. The SONET add/drop multiplexer aggregates lesser bit speed services onto the dedicated SONET ring or the two-point SONET circuit configuration.

20.2 Description

Optical Networking is comprised of high speed SONET based and/or DWDM technology providing connectivity at, and transport between, two or more customer designated locations (CDLs).

All traffic must originate and/or terminate at the IC customer location.

## FACILITIES FOR INTERSTATE ACCESS

20. Optical Networking (Cont'd)20.3 Conditions

Optical Networking services are provided where facilities are available with sufficient bandwidth capacity to meet the customer's request.

The customer is responsible for providing all facilities and cabling necessary to connect customer equipment to this interface.

The customer will be billed additional charges for any charges levied the Company for space and power required to place equipment on the company's side of the network interface.

Customer Facility Assignment (CFA) is controlled by the Company, on all access customer serving wire centers on the IOF and extends to the terminating CDL. Should the customer require control of the facility assignment and order multiplexing on the IOF, the services from the multiplexer to the end user serving wire center will be ordered from Section 5 of this service guide.

It is the customer's responsibility to ensure that the customer's equipment provides industry standard electrical signals compatible with Optical Networking transport transmission. Technical specifications are contained in the following publications:

Bellcore Document GR-253-CORE, Issue 2, April, 1996  
Bellcore Document GR-1400-CORE, Issue 1, March, 1994  
Bellcore Document GT-1374-CORE, Issue 1, March, 1994  
American National Standard, ANSI T1.105-1996  
American National Standard, ANSI T1.102-1993

The Company will work cooperatively with the customer during a planning session to insure that the customer orders sufficient Optical Networking bandwidth capacity to satisfy the customer's requirements as well as other applicable Optical Networking services. This planning session must take place prior to an initial Optical Networking ASR.

## FACILITIES FOR INTERSTATE ACCESS

20. Optical Networking (Cont'd)20.4 Application of Rates and Charges(1) CONNECT<sup>[1]</sup>

The Connect rate element provides the platform for customer access to the Company's Optical Network. The Connect element provides the link between the CDL and the SWC of the CDL.

There are three types of Connects:

- Single Route Connect \*
- Dual Route Connect \*
- Ring Connect \*
- CO Connect \*
- Shared Connect \*
- Jointly Provided Custom Connect \*
- Wholly Provided Custom Connect \*
- Custom Connect<sup>[1]</sup>

## (a) Single Route Connect \*

The Single Route provides a connection to the Company's wire center(s) via a point-to-point route configuration. The Single Route Connect may be provided as electrical or optical interface in OC bandwidths of OC3, OC12, OC24 or OC48. The Single Route Connect may be ordered as switched or special access.

## (b) Dual Route Connect \*

The Dual Route Connect provides a connection to the Company's wire center(s) in which the working transmission path traverses a distinct and separate path from the protection transmission path. The Dual Route Connect may be provided as electrical or optical interface in OC bandwidths of OC3, OC12, OC24 or OC48. The Dual Route Connect may be ordered as switched or special access.

## (c) Ring Connect \*

The Ring Connect provides a connection to the Company's wire centers via a ring topology that provides no single point of failure. The Ring Connect has a minimum of three nodes one of which must be a Company wire center. The Ring Connect may be provided as either electrical or optical interface in OC bandwidths of OC3, OC12, OC24 or OC48. When two of the nodes are customer designated locations, at least one of those nodes must be electrical. The Ring Connect may be ordered as switched or special access.

\* Grandfathered to existing service effective December 26, 1998.

[1] Effective March 1, 2022 Custom Connect with terms of 36, 60 or 84 months will be grandfathered until the expiration date of the current term. As of this effective date, 36, 60 and 84 month term renewals will not be offered on this plan. Upon expiration of the current term, rates will revert to month-to-month/one year. CUSTOM CONNECT OC-192 Point-to-Point configurations are grandfathered as of February 11, 2019 and will no longer be available for new service requests. This does not impact CUSTOM CONNECT OC-192 Multipoint or Ring configurations.

## FACILITIES FOR INTERSTATE ACCESS

20. Optical Networking20.4 Application of Rates and Charges(1) CONNECT (Cont'd)

## (d) CO Connect \*

The CO Connect provides access to the Company's Optical Networking platform. The CO Connect is provided at DS3, DS1 and DS0 levels. The appropriate special access line from Section 5 will apply.

When a CO Connect is provided at a DS3 or DS1 level, the customer may order multiplexing, as shown in Section 5, at the end user serving wire center. The customer will be charged for the multiplexing in addition to the CO Connect.

When a CO Connect is ordered at a DS0 level, the customer must request a minimum of a DS1 interface at the IC customer wire center and will be charged for the appropriate payload (i.e., DS1 or DS3) at the IC customer wire center. The CO connect may be ordered as switched or special access.

## (e) Shared Connect \*

The Shared Connect is a SONET based DS1 or DS3 that is provided on a shared SONET facility basis to multiple customer designated locations. The Shared Connect is only available where existing SONET infrastructure is in place.

The Shared Connect may be provided as either a dual route or as ring topology.

## (f) Jointly Provided Custom Connect (Custom Connect- JP) \*

The Jointly Provided Custom Connect provides a connection to the Company's SONET wire center(s) to an access customer's designated location (CDL) where service is provided by another telephone company. The Jointly Provided Custom Connect is mileage sensitive and may be provided in OC bandwidths of OC3, OC12, OC24 and OC48 as an electrical option only, i.e., the Company provided electronics. Mileage will be calculated based on the V&H coordinates of the wire centers comprising each segment of the connect. The meet point billing mileage calculation is specified in 2.7.3.

Payloads are included in the monthly rate for the Jointly Provided Custom Connect. However, access to CDLs provided by the Company require other Optical Networking rate elements as ordered by the customer, i.e., Ring Connect and Payloads, CO Connect and SAL(s), Transport, etc. The serving wire center(s) of the Company provided CDLs must be part of the Jointly Provided Custom Connect.

The Jointly Provided Custom Connect may be ordered as switched or special access.

\* Grandfathered to existing service effective December 26, 1998.

## FACILITIES FOR INTERSTATE ACCESS

20. Optical Networking20.4 Application of Rates and Charges(1) CONNECT (Cont'd)

## (g) Wholly Provided Custom Connect (Custom Connect - WP) \*

The Wholly Provided Custom Connect provides a connection to the Company's SONET wire center(s), an interexchange access customer designated location (CDL), and the access customer's end user CDL(s) via a ring topology. The Wholly Provided Custom Connect may be provided in OC bandwidths of OC3, OC12 or OC48.

The Wholly Provided Custom Connect is comprised of four rate elements, CDL Node, CO Node, Custom Connect (CC) Transport and CC Rider. The CDL Node rate element is applicable for each customer designated location, the CO Node is applicable for each central office that is equipped with a fiber optic terminal in which the customer requests the ability to add/drop traffic to a CDL and the CC Transport rate element is applicable for transport from the serving wire centers of the customer designated locations and CO Nodes. The CC Rider is the customer service riding the CC Transport. The CC Rider may be provided at DS1, DS3, OC3 and OC3c bandwidth levels as required by the customer. The bandwidth of the CDL Nodes, CO Nodes and CC Transport rate elements must be the same.

The CC Transport provides distance sensitive transport on a ring topology. The transport is measured from the primary serving wire centers of the customer designated locations and the CO Nodes.

In addition to the Wholly Provided Custom Connect rate elements, the appropriate special access line (SAL) from Section 5 is applicable from the CO Node to the customer designated location where traffic is entering the Wholly Provided Custom Connect at a DS1 or DS3 bandwidth level as required by the customer.

The Wholly Provided Custom Connect may be ordered as switched or special access.

\* Grandfathered to existing service effective December 26, 1998.

## FACILITIES FOR INTERSTATE ACCESS

20. Optical Networking  
20.4 Application of Rates and Charges  
(1) CONNECT (Cont'd)

(h) Custom Connect<sup>[1]</sup>

The Custom Connect provides a connection to the Company's Optical Network and an access customer's designated location (CDL). The Custom Connect is comprised of CO Nodes, CDL Links, Transport and Riders. Each Custom Connect must consist of a minimum of two customer designated locations, one of which must be a CDL Link.

The Custom Connect may be ordered as switched or special access.

CO Node

The CO Node rate element is applicable for each central office that is equipped with a fiber optic terminal in which the customer requests the ability to add/drop traffic to a CDL. If the customer wants to drop traffic below a DS3 at the CO Node, the customer must request a minimum DS1 interface and appropriate special access lines from Section 5. The CO Node may also be used when the customer wants to add/drop DS1 or DS3 traffic to a CDL located between the service areas shown under Section 5.2.7(H). The appropriate multiplexing and access lines and transport rates from Section 5 will apply in addition to the CO Node and appropriate rider charges. The CO Node may be ordered at an OC3, OC12, OC48 or OC192 bandwidth capacity. The OC192 CO Node cannot drop traffic below the Ocn level. The CO Node may be ordered under a one (1) year, three (3) year, five (5) year or seven (7) year Term Payment Plan (TPP).

The CO Node may be ordered when a customer requires OC level multiplexing on the Custom Connect.

[1] Effective March 1, 2022 Custom Connect with terms of 36, 60 or 84 months will be grandfathered until the expiration date of the current term. As of this effective date, 36, 60 and 84 month term renewals will not be offered on this plan. Upon expiration of the current term, rates will revert to month-to-month/one year. CUSTOM CONNECT OC-192 Point-to-Point configurations are grandfathered as of February 11, 2019 and will no longer be available for new service requests. This does not impact CUSTOM CONNECT OC-192 Multipoint or Ring configurations.

## FACILITIES FOR INTERSTATE ACCESS

20. Optical Networking20.4 Application of Rates and Charges(1) CONNECT<sup>[1]</sup>

## (h) Custom Connect (Cont'd)

CDL Link

The CDL Link rate element is applicable for each customer designated location in which the customer requests the ability to add/drop traffic. The CDL Link is offered as Single Route, Diverse Route or Ring Route and may be ordered with or without Company provided electronics as OC3, OC12, OC48 or OC192 bandwidth capacity. Only one CDL Link per connect may be ordered without electronics.

If more than two Links or Nodes are ordered on the same order, the CDL Link must be ordered as a Ring Route CDL Link. A Custom Connect ordered via a ring topology will be provided with a service guarantee as shown in 2.4.4(A)(8).

The CDL Link may be ordered as OC3c, OC12c or OC48c Single Route or Diverse Route with Company provided electronics. OC3c, OC12c and OC48c rider charges are included in the monthly rate for OC3c, OC12c and OC48c CDL Links.

The CDL Link may also be ordered as 1.25 Gbps and 2.5 Gbps Single Route or Diverse Route. This CDL Link cannot ride a higher level facility and can only be ordered CDL to CDL.

The CDL Link may be ordered under a one (1) year, three (3) year, five (5) year or seven (7) year TPP.

CDL Link with Optical Cross Connect

The CDL Link with Optical Cross Connect provides the communications path between the Company provided electronics and a customer's transmission equipment and facilities where the customer is provided EIS as defined in Section 17. This rate element includes the CDL Link from the fiber optic terminal and the optical jumpers to facilitate the cross connect to the customer's transmission equipment and facilities within the Company wire center.

The CDL Link with Optical Cross Connect will be provided as single route without Company provided electronics as OC3, OC3c, OC12, OC12c, OC48, OC48c or OC192 as ordered by the customer.

In addition to the rate for the CDL Link with Optical Cross Connect, the appropriate CDL Link rate element is applicable from the customer-designated location to the serving wire center.

The CDL Link with Optical Cross Connect may be ordered under a one (1) year, three (3) year, five (5) year or seven (7) year TPP.

Rates for the CDL Link with Optical Cross Connect are shown in 20(J) will apply in addition to other charges specified in Section 17.

[1] Effective March 1, 2022 Custom Connect with terms of 36, 60 or 84 months will be grandfathered until the expiration date of the current term. As of this effective date, 36, 60 and 84 month term renewals will not be offered on this plan. Upon expiration of the current term, rates will revert to month-to-month/one year.

## FACILITIES FOR INTERSTATE ACCESS

20. Optical Networking20.4 Application of Rates and Charges(1) CONNECT<sup>[1]</sup>

## (h) Custom Connect (Cont'd)

Regeneration Charge

Due to the technical limitations of SONET facilities, additional regeneration equipment may be required for essential detection and retransmission of SONET signals between the customer's premises and the Company serving wire center for that premise. Additional regeneration equipment will only be provided by the Company when the actual fiber facility distance between the customer's premise and serving wire center exceeds SONET design limits.

A monthly recurring sonnet Regeneration charge, as set forth in 20 (J) following, will apply for each regenerator required for the provision of Custom Connect service.

Capacity Reconfiguration Charge

Upon ordering Custom Connect service, the customer is responsible for identifying the STS signal configuration. This information is used in determining the route and connection in the network.

If a new configuration is requested subsequent to the initial activation, a service reconfiguration charge will apply on a per service basis, as set forth in 20 (J). The service reconfiguration charge is in addition to all applicable configuration node and configuration rider charges associated with the new configuration.

Transport

Transport may be ordered as shared or dedicated. Shared Transport is applicable when the transport between Node and/or Links is ordered at different bandwidth levels. The Dedicated Transport is applicable when transport between the Nodes and/or Links is of the same bandwidth level.

Shared Transport may be ordered in bandwidths of DS1, DS3/STS1, OC3, OC3c, OC12, OC12c, OC48 or OC48c. Dedicated Transport may be ordered in bandwidths of OC3, OC3c, OC12, OC12c, OC48, OC48c or OC192, 1.25 Gbps or 2.5 Gbps. The transport is mileage sensitive and will be calculated based on the V&H coordinates of the wire centers comprising each segment of the connect. The meet point billing mileage calculation is specified in 2.7.3. The customer has the option to subscribe to \*Banded Optical Transport in place of Custom Connect Shared Transport.

The Transport is provided at a flat-rated monthly recurring charge.

[1] Effective March 1, 2022 Custom Connect with terms of 36, 60 or 84 months will be grandfathered until the expiration date of the current term. As of this effective date, 36, 60 and 84 month term renewals will not be offered on this plan. Upon expiration of the current term, rates will revert to month-to-month/one year.



## FACILITIES FOR INTERSTATE ACCESS

20. Optical Networking20.4 Application of Rates and Charges (Cont'd)(2) Optical Network Transport \*

The transport element provides for the interoffice Optical Network transport between wire centers on Company defined LANs. Each IC customer Connect must have its own transport. Transport cannot be shared among IC customer Connects.

Optical Network Transport may be provided as LAN-wide, LAN-wide Premium, Point-to-Point, or Ring Per-Mile Transport in bandwidth capacities of OC1, OC3, OC12, OC24 and OC48. J-SONET Transport may be purchased in DS0, DS1 or DS3 bandwidths. Band SONET Transport may be purchased in DS0, DS1, DS3, OC3 or OC12 Bandwidths.

- (a) LAN-wide Transport provides transport between two or more Incremental SONET designated wire centers located on the IOF transport. LAN-wide Transport is provided at a non-distance sensitive flat-rated monthly charge per LAN traversed. LAN-Wide Transport is not guaranteed. However, the customer will have protection routing topology. Multiple Connects served from any of the Incremental SONET designated terminating wire center on the LAN may utilize this element. LAN-wide Transport may be ordered as switched or special access.
- (b) LAN-wide Premium Transport provides the same as LAN-wide Transport. Provisioning of LAN-wide Premium Transport provides a quicker restoral time. LAN-wide Premium Transport is provided at a flat-rated monthly charge per LAN traversed. LAN-wide Premium Transport may be ordered as switched or special access.
- (c) Point-to-Point Transport provides transport between the serving wire centers associated with two CDLs. Point-to-Point Transport is provided at a distance sensitive rate on a per airline mile basis. Mileage is measured between the wire centers of the customer designated locations. Point-to-Point Transport may be ordered as switched or special access.
- (d) Ring Per-Mile Transport provides distance sensitive transport on a ring topology. The transport is measured in airline miles from the primary serving wire centers of the customer designated locations. Ring-Per-Mile Transport may be ordered as switched or special access.

Ring Per-Mile Transport provides a service guarantee as shown in 2.4.4(A)(8).

- (e) J-SONET Transport provides transport between the serving wire centers of the CDLs. J-SONET Transport may be provided at DS0, DS1 or DS3 bandwidth levels as required by the customer. The bandwidth of the transport must be the same as the bandwidth of the CO Connect or the payload, e.g., DS0 J-SONET requires a DS0 connect and DS3 J-SONET Transport requires a DS3 CO Connect. J-SONET Transport may be ordered as switched or special access.

J-SONET Transport is provided at a non-distance sensitive flat rated monthly charge per LAN traversed.

\* Grandfathered to existing service effective December 26, 1998.

## FACILITIES FOR INTERSTATE ACCESS

20. Optical Networking20.4 Application of Rates and Charges(2) Optical Network Transport \* (Cont'd)

- (f) Banded Optical Transport provides transport between the serving wire center of the interexchange access customer's location and the access customer's end user premises. Banded Optical Transport may be provided at DS0, DS1, DS3, OC3, E1, STS1, STM1, STM4, OC12 or OC48 bandwidth levels as required by the customer. Wholly provided Banded Optical Transport may also be provided at OC3c, OC12c and OC48c bandwidth levels. When Banded Optical is ordered at a DSO level, the customer must request a minimum of a DS1 interface at the IC customer wire center and will be charged for the appropriate rider (i.e., DS1 or DS3). Banded Optical Transport is provided with a service guarantee as shown in 2.4.4(A)(8). For subscription to Banded Optical Transport, the customer must have an accumulative demand requirement equivalent to an average of nine DS3s, i.e., 5,978 channels, per LATA. The bandwidth will be reviewed annually at a mutually agreed upon date by the customer and the Company. An allowance of minus 2% will be considered as having met the commitment level. Should the bandwidth fall below minus 2%, the customer will have thirty (30) days to meet the bandwidth requirement. If not met, the customer will be notified by the Company and will be required to convert from Banded Optical Transport to another Optical Networking Transport option.

Banded Optical Transport is provided at a flat-rated monthly charge for one (1) year, three (3) year, five (5) year, or seven (7) year Term Payment Plans (TPPs). The term period for Banded Optical Transport cannot exceed the term period of the Connect. Banded Optical Transport includes the special access line from the end user serving wire center to the end user premises, for both on-net and off-net, with the exception of jointly provided Banded Optical Transport. Banded Optical Transport will be provisioned at the highest network facility available at the time of the order. The monthly rate will be determined based on the mileage between the serving wire centers of the customer designated locations and is applicable on a per circuit basis. Mileage will be rounded up to the next whole mile except when the CDLs are collocated.

When both customer designated locations are provided by the Company, wholly provided, the monthly rates as shown in 20(J) are applicable. When one of the customer designated locations is provided by another telephone company, or the customer terminates at a multiplexer in a wire center on the IOF, jointly provided, the monthly rates as shown in 20(J) shall apply. For jointly provided transport with another telephone company, the meet point billing mileage calculation is specified in Section 2.7.3.

Banded Optical Transport may be ordered as switched or special access.

\* Grandfathered to existing service effective December 26, 1998.

## FACILITIES FOR INTERSTATE ACCESS

20. Optical Networking20.4 Application of Rates and Charges(2) Optical Network Transport \* (Cont'd)

- (g) Expanded Band Optical Transport provides transport between the interexchange access customer's location and the access customer's end user location. Expanded Band Optical Transport may be provided at DS1, DS3, OC3, OC3c, OC12, OC12c, STS1, E1 or STM1 bandwidth levels as required by the customer. For subscription to Expanded Band Optical Transport, the customer must have an accumulative demand requirement equivalent to an average of nine DS3's, i.e., 5,978 channels, per LATA. The bandwidth will be reviewed annually at a mutually agreed upon date by the customer and the Company. An allowance of minus 2% will be considered as having met the commitment level. Should the bandwidth fall below minus 2%, the customer will have thirty (30) days to meet the bandwidth requirement. If not met, the customer will be notified by the Company and will be required to convert from Expanded Band Optical to another Optical Network Transport option.

Expanded Band Optical Transport is provided at a flat-rated monthly charge for one (1) year, three (3) year, five (5) year or seven (7) year contract periods at the rates shown in 20(J). Expanded Band Optical Transport includes the special access line from the access customer's serving wire center to the access customer's premises and from the end user serving wire center to the end user premises. Expanded Band Optical Transport will be provisioned at the highest network facility available at the time of the order. The monthly rate will be determined based on the mileage between the serving wire centers of the customer designated locations and is applicable on a per circuit basis. Mileage will be rounded to the next whole mile except when CDLs are collocated.

(3) Payload \*

Payload is the customer service riding on the shared IOF transport and/or the activation of the service(s). Payload is provided at a flat-rated monthly recurring charge which includes add/drop multiplexing and is applicable at the wire center for each customer designated location, with the exception of CO Connects, Banded Optical Transport and Wholly Provided Custom Connect. Payload services include DS1, DS3, OC3, OC3c, OC12, OC12c, STS1 and STM1. Payload services may be ordered as switched or special access.

The monthly rates for DS1 payloads are shown in 20.9.

\* Grandfathered to existing service effective December 26, 1998.

## FACILITIES FOR INTERSTATE ACCESS

20. Optical Networking (Cont'd)20.5 Incremental Growth \*

Incremental Growth facilitates a customer's growth in increments of OC3. Incremental Growth applies only to Connect.

Incremental Growth may be ordered as switched or special access.

20.6 Rate Regulations <sup>[1]</sup>

Optical Networking may be ordered under a one (1), three (3), five (5), or seven (7) year Term Payment Plan (TPP). Any TPP for these services is subject to an TPP Termination Liability Charge as specified herein.

(1) Changes in Length of a TPP <sup>[1]</sup>

Prior to the expiration of a TPP period, the customer may elect to convert to a new TPP period of the same or different length, subject to the following conditions:

- No credit will be given for the new period for payments made under the original TPP arrangement.
- NRCs will not be reapplied for existing services.
- If the new TPP period is shorter in length than the time remaining under the existing TPP, the change to the new TPP period constitutes a disconnect of the existing TPP service and termination liability charges will apply.
- The rates for the new period will be the rates currently in effect at the time of the change.
- If the customer subscribes to a new TPP which is greater in length than the initial TPP term and discontinues one or all of the service elements prior to the expiration of the new termination liability period, the termination liability, as set forth below, will apply based on the remainder of the TPP period in effect at the time of the disconnect.

Year in which Service Is Discontinued	Liability Rate
1	100%
2	75%
3	50%
4 or more	25%

\* Grandfathered to existing service effective December 26, 1998.

[1] Effective March 1, 2022 Custom Connect with terms of 36, 60 or 84 months will be grandfathered until the expiration date of the current term. As of this effective date, 36, 60 and 84 month term renewals will not be offered on this plan. Upon expiration of the current term, rates will revert to month-to-month/one year.

Effective: October 4, 2022

Original Page 20-13

## FACILITIES FOR INTERSTATE ACCESS

20. Optical Networking20.6 Rate Regulations <sup>[1]</sup> (Cont'd)(2) Renewal Options

Ninety (90) days prior to the expiration of the existing TPP, the customer shall submit in writing to select current month-to-month/1 year service rates or disconnect service. If no notice is received, the Company will automatically renew at month-to-month/one year rates from the current service guide..

After completion of the initial TPP term and the customer subscribes to a new term that is longer in length the termination liability, as set forth below, will apply based on the remainder of the TPP period in effect at the time of the disconnect.

<u>Year in which Service Is Discontinued</u>	<u>Liability Rate</u>
1	20%
2	15%
3	10%
4 or more	5%

(3) Conversion

When an existing customer purchases Optical Networking, the customer may upgrade their existing special access services to Optical Networking. The upgrade may require physical network changes, as well as changes to existing billing arrangements. Physical changes consist of reterminating existing services not currently utilizing the Optical network.

Termination liability charges will not apply to the customer's existing services provided the Optical Networking TPP term commitment agreement is equal to or longer in length than the time remaining for the existing arrangement.

(4) Rate Changes

The TPP rates are exempt from Company initiated increases for the length of the plan, however, decreases will be passed on to the customer. Rate changes may occur as a result of FCC action.

(5) Termination Liability

In the event the customer discontinues one or all of the service elements (Connect, Banded Optical Transport) prior to the end of the termination liability period, initial termination liability charges, as set forth below, will apply based on the remainder of the TPP period in effect at the time of the disconnect.

<u>Year in which Service Is Discontinued</u>	<u>Liability Rate</u>
1	40%
2	35%
3	30%
4 or more	25%

[1] Effective March 1, 2022 Custom Connect with terms of 36, 60 or 84 months will be grandfathered until the expiration date of the current term. As of this effective date, 36, 60 and 84 month term renewals will not be offered on this plan. Upon expiration of the current term, rates will revert to month-to-month/one year.

## FACILITIES FOR INTERSTATE ACCESS

20. Optical Networking20.6 Rate Regulations <sup>[1]</sup>(Cont'd)(6) Termination Without Liability

For Banded Optical Transport, termination charges will not apply when the customer disconnects a DS0 or DS1 on a circuit by circuit basis provided the required accumulative bandwidth is met.

(7) Upgrade to Higher Bandwidth

The Customer who has grown incrementally, may elect to upgrade service to a higher bandwidth during a TPP period to gain economic efficiencies. Termination charges will not apply as long as the upgraded service remains connected at the same point of termination(s), unless the network is being redesigned to gain network efficiency. Nonrecurring charges associated with the new bandwidth upgrade shall apply.

20.7 Off-Net Wire Center

Off-Net wire center is a wire center not a designated Optical Networking wire center office. The customer may order a DS0, DS1 or DS3 to the Off-Net wire center. Mileage charges will be determined based on airline miles to the nearest on-net wire center at the transport rates shown in Section 5.

Circuits connected to the Off-Net wire center will be billed existing rates as shown in Section 5.

20.8 Reserved For Future Use

[1] Effective March 1, 2022 Custom Connect with terms of 36, 60 or 84 months will be grandfathered until the expiration date of the current term. As of this effective date, 36, 60 and 84 month term renewals will not be offered on this plan. Upon expiration of the current term, rates will revert to month-to-month/one year.

Effective: October 4, 2022

Original Page 20-15

## FACILITIES FOR INTERSTATE ACCESS

20. Optical Networking (Cont'd)20.9 Rates and Charges

## (1) Custom Connect CO Node - OC3

	<u>Nonrecurring Charge</u>	<u>One Year Monthly Rate</u>	<u>Three Year Monthly Rate</u> <sup>[1]</sup>	<u>Five Year Monthly Rate</u> <sup>[1]</sup>	<u>Seven Year Monthly Rate</u> <sup>[1]</sup>
<u>Jurisdiction</u>					
Alabama#	\$197.00	\$2,034.50	\$1,465.00	\$1,360.00	\$1,260.00
Missouri	\$1,500.00	\$1,235.00	\$900.00	\$850.00	\$800.00

## (2) Custom Connect CO Node - OC12

	<u>Nonrecurring Charge</u>	<u>One Year Monthly Rate</u>	<u>Three Year Monthly Rate</u> <sup>[1]</sup>	<u>Five Year Monthly Rate</u> <sup>[1]</sup>	<u>Seven Year Monthly Rate</u> <sup>[1]</sup>
<u>Jurisdiction</u>					
Alabama#	\$197.00	\$3,393.00	\$2,435.00	\$2,260.00	\$2,085.00
Missouri	\$3,000.00	\$2,925.00	\$2,150.00	\$2,050.00	\$1,975.00

## (3) Custom Connect CO Node - OC48

	<u>Nonrecurring Charge</u>	<u>One Year Monthly Rate</u>	<u>Three Year Monthly Rate</u> <sup>[1]</sup>	<u>Five Year Monthly Rate</u> <sup>[1]</sup>	<u>Seven Year Monthly Rate</u> <sup>[1]</sup>
<u>Jurisdiction</u>					
Alabama#	\$197.00	\$4,699.50	\$3,375.00	\$3,130.00	\$2,900.00
Missouri	\$3,000.00	\$5,850.00	\$4,300.00	\$4,100.00	\$3,900.00

(4) Custom Connect CO Node – OC192<sup>(1)</sup>

	<u>Nonrecurring Charge</u>	<u>One Year Monthly Rate</u>	<u>Three Year Monthly Rate</u> <sup>[1]</sup>	<u>Five Year Monthly Rate</u> <sup>[1]</sup>	<u>Seven Year Monthly Rate</u> <sup>[1]</sup>
<u>Jurisdiction</u>					
Alabama#	\$197.00	\$6,506.50	\$4,680.00	\$4,335.00	\$4,035.00
Missouri	\$6,000.00	\$14,625.00	\$10,750.00	\$10,250.00	\$9,750.00

# Rates applicable for special access only.

[1] Effective March 1, 2022 Custom Connect with terms of 36, 60 or 84 months will be grandfathered until the expiration date of the current term. As of this effective date, 36, 60 and 84 month term renewals will not be offered on this plan. Upon expiration of the current term, rates will revert to month-to-month/one year. CUSTOM CONNECT OC-192 Point-to-Point configurations are grandfathered as of February 11, 2019 and will no longer be available for new service requests. This does not impact CUSTOM CONNECT OC-192 Multipoint or Ring configurations

ISG2022-01(BLOC)

Effective: October 4, 2022

Original Page 20-16

## FACILITIES FOR INTERSTATE ACCESS

20. Optical Networking  
20.9 Rates and Charges (Cont'd)

## (5) Custom Connect CDL Link - Single Route with Company Electronics - OC3

	<u>Nonrecurring Charge</u>	<u>One Year Monthly Rate</u>	<u>Three Year Monthly Rate</u> <sup>[1]</sup>	<u>Five Year Monthly Rate</u> <sup>[1]</sup>	<u>Seven Year Monthly Rate</u> <sup>[1]</sup>
<u>Jurisdiction</u>					
Alabama#	\$315.00	\$4,485.00	\$2,560.00	\$2,255.00	\$2,000.00
Missouri	\$3,000.00	\$1,547.00	\$1,100.00	\$1,050.00	\$1,000.00

## (6) Custom Connect CDL Link - Single Route without Company Electronics - OC3

	<u>Nonrecurring Charge</u>	<u>One Year Monthly Rate</u>	<u>Three Year Monthly Rate</u> <sup>[1]</sup>	<u>Five Year Monthly Rate</u> <sup>[1]</sup>	<u>Seven Year Monthly Rate</u> <sup>[1]</sup>
<u>Jurisdiction</u>					
Alabama#	\$315.00	\$3,068.00	\$1,750.00	\$1,540.00	\$1,370.00
Missouri	\$1,500.00	\$864.50	\$650.00	\$620.00	\$580.00

## (7) Custom Connect CDL Link - Single Route with Company Electronics - OC3c

	<u>Nonrecurring Charge</u>	<u>One Year Monthly Rate</u>	<u>Three Year Monthly Rate</u> <sup>[1]</sup>	<u>Five Year Monthly Rate</u> <sup>[1]</sup>	<u>Seven Year Monthly Rate</u> <sup>[1]</sup>
<u>Jurisdiction</u>					
Alabama#	\$315.00	\$5,960.50	\$3,610.00	\$3,235.00	\$2,910.00
Missouri	\$6,000.00	\$4,290.00	\$3,150.00	\$2,950.00	\$2,800.00

# Rates applicable for special access only.

[1] Effective March 1, 2022 Custom Connect with terms of 36, 60 or 84 months will be grandfathered until the expiration date of the current term. As of this effective date, 36, 60 and 84 month term renewals will not be offered on this plan. Upon expiration of the current term, rates will revert to month-to-month/one year.



Effective: October 4, 2022

Original Page 20-17

## FACILITIES FOR INTERSTATE ACCESS

20. Optical Networking20.9 Rates and Charges (Cont'd)

## (8) Custom Connect CDL Link - Single Route with Company Electronics - OC12

	<u>Nonrecurring Charge</u>	<u>One Year Monthly Rate</u>	<u>Three Year Monthly Rate</u> <sup>[1]</sup>	<u>Five Year Monthly Rate</u> <sup>[1]</sup>	<u>Seven Year Monthly Rate</u> <sup>[1]</sup>
<u>Jurisdiction</u>					
Alabama#	\$315.00	\$5,460.00	\$3,250.00	\$2,900.00	\$2,600.00
Missouri	\$6,000.00	\$3,315.00	\$2,400.00	\$2,200.00	\$2,050.00

## (9) Custom Connect CDL Link - Single Route without Company Electronics-OC12

	<u>Nonrecurring Charge</u>	<u>One Year Monthly Rate</u>	<u>Three Year Monthly Rate</u> <sup>[1]</sup>	<u>Five Year Monthly Rate</u> <sup>[1]</sup>	<u>Seven Year Monthly Rate</u> <sup>[1]</sup>
<u>Jurisdiction</u>					
Alabama#	\$315.00	\$3,601.00	\$2,140.00	\$1,910.00	\$1,710.00
Missouri	\$1,500.00	\$845.00	\$620.00	\$600.00	\$580.00

## (10) Custom Connect CDL Link - Single Route with Company Electronics - OC12c

	<u>Nonrecurring Charge</u>	<u>One Year Monthly Rate</u>	<u>Three Year Monthly Rate</u> <sup>[1]</sup>	<u>Five Year Monthly Rate</u> <sup>[1]</sup>	<u>Seven Year Monthly Rate</u> <sup>[1]</sup>
<u>Jurisdiction</u>					
Alabama#	\$315.00	\$13,903.50	\$9,335.00	\$8,530.00	\$7,815.00
Missouri	\$6,000.00	\$8,710.00	\$6,350.00	\$6,150.00	\$5,950.00

# Rates applicable for special access only.

[1] Effective March 1, 2022 Custom Connect with terms of 36, 60 or 84 months will be grandfathered until the expiration date of the current term. As of this effective date, 36, 60 and 84 month term renewals will not be offered on this plan. Upon expiration of the current term, rates will revert to month-to-month/one year.

Effective: October 4, 2022

Original Page 20-18

## FACILITIES FOR INTERSTATE ACCESS

20. Optical Networking  
20.9 Rates and Charges (Cont'd)

## (11) Custom Connect CDL Link - Single Route with Company Electronics - OC48

<u>Jurisdiction</u>	<u>Nonrecurring Charge</u>	<u>One Year Monthly Rate</u>	<u>Three Year Monthly Rate</u> <sup>[1]</sup>	<u>Five Year Monthly Rate</u> <sup>[1]</sup>	<u>Seven Year Monthly Rate</u> <sup>[1]</sup>
Alabama#	\$315.00	\$13,227.50	\$8,850.00	\$8,080.00	\$7,400.00
Missouri	\$6,000.00	\$6,045.00	\$4,230.00	\$4,020.00	\$3,800.00

## (12) Custom Connect CDL Link - Single Route without Company Electronics- OC48

<u>Jurisdiction</u>	<u>Nonrecurring Charge</u>	<u>One Year Monthly Rate</u>	<u>Three Year Monthly Rate</u> <sup>[1]</sup>	<u>Five Year Monthly Rate</u> <sup>[1]</sup>	<u>Seven Year Monthly Rate</u> <sup>[1]</sup>
Alabama#	\$315.00	\$7,579.00	\$5,070.00	\$4,630.00	\$4,240.00
Missouri	\$1,500.00	\$910.00	\$650.00	\$620.00	\$600.00

## (13) Custom Connect CDL Link - Single Route with Company Electronics – OC48c

<u>Jurisdiction</u>	<u>Nonrecurring Charge</u>	<u>One Year Monthly Rate</u>	<u>Three Year Monthly Rate</u> <sup>[1]</sup>	<u>Five Year Monthly Rate</u> <sup>[1]</sup>	<u>Seven Year Monthly Rate</u> <sup>[1]</sup>
Alabama#	\$315.00	\$35,503.00	\$24,100.00	\$22,515.00	\$21,060.00
Missouri	\$6,000.00	\$16,250.00	\$12,250.00	\$12,000.00	\$11,750.00

# Rates applicable for special access only.

[1] Effective March 1, 2022 Custom Connect with terms of 36, 60 or 84 months will be grandfathered until the expiration date of the current term. As of this effective date, 36, 60 and 84 month term renewals will not be offered on this plan. Upon expiration of the current term, rates will revert to month-to-month/one year.

Effective: October 4, 2022

Original Page 20-19

## FACILITIES FOR INTERSTATE ACCESS

20. Optical Networking  
20.9 Rates and Charges (Cont'd)(14) Custom Connect CDL Link - Single Route with Company Electronics – OC192 <sup>(1)</sup>

	<u>Nonrecurring Charge</u>	<u>One Year Monthly Rate</u>	<u>Three Year Monthly Rate</u> <sup>[1]</sup>	<u>Five Year Monthly Rate</u> <sup>[1]</sup>	<u>Seven Year Monthly Rate</u> <sup>[1]</sup>
<u>Jurisdiction</u>					
Alabama#	\$315.00	\$32,045.00	\$24,100.00	\$22,515.00	\$21,060.00
Missouri	\$12,000.00	\$15,112.50	\$11,200.00	\$11,000.00	\$10,900.00

(15) Custom Connect CDL Link - Single Route without Company Electronics- OC192 <sup>(1)</sup>

	<u>Nonrecurring Charge</u>	<u>One Year Monthly Rate</u>	<u>Three Year Monthly Rate</u> <sup>[1]</sup>	<u>Five Year Monthly Rate</u> <sup>[1]</sup>	<u>Seven Year Monthly Rate</u> <sup>[1]</sup>
<u>Jurisdiction</u>					
Alabama#	\$315.00	\$15,951.00	\$12,010.00	\$11,225.00	\$10,515.00
Missouri	\$1,500.00	\$3,412.50	\$2,450.00	\$2,325.00	\$2,250.00

## (16) Custom Connect CDL Link - Diverse Route with Company Electronics - OC3

	<u>Nonrecurring Charge</u>	<u>One Year Monthly Rate</u>	<u>Three Year Monthly Rate</u> <sup>[1]</sup>	<u>Five Year Monthly Rate</u> <sup>[1]</sup>	<u>Seven Year Monthly Rate</u> <sup>[1]</sup>
<u>Jurisdiction</u>					
Alabama#	\$315.00	\$6,727.50	\$3,840.00	\$3,383.00	\$3,000.00
Missouri	\$3,000.00	\$2,327.00	\$1,700.00	\$1,650.00	\$1,600.00

# Rates applicable for special access only.

[1] Effective March 1, 2022 Custom Connect with terms of 36, 60 or 84 months will be grandfathered until the expiration date of the current term. As of this effective date, 36, 60 and 84 month term renewals will not be offered on this plan. Upon expiration of the current term, rates will revert to month-to-month/one year. CUSTOM CONNECT OC-192 Point-to-Point configurations are grandfathered as of February 11, 2019 and will no longer be available for new service requests. This does not impact CUSTOM CONNECT OC-192 Multipoint or Ring configurations.

Effective: October 4, 2022

Original Page 20-20

## FACILITIES FOR INTERSTATE ACCESS

20. Optical Networking  
20.9 Rates and Charges (Cont'd)

## (17) Custom Connect CDL Link - Diverse Route without Company Electronics - OC3

<u>Jurisdiction</u>	<u>Nonrecurring Charge</u>	<u>One Year Monthly Rate</u>	<u>Three Year Monthly Rate</u> <sup>[1]</sup>	<u>Five Year Monthly Rate</u> <sup>[1]</sup>	<u>Seven Year Monthly Rate</u> <sup>[1]</sup>
Alabama#	\$315.00	\$5,525.00	\$3,150.00	\$2,770.00	\$2,605.00
Missouri	\$3,000.00	\$1,560.00	\$1,165.00	\$1,125.00	\$1,100.00

## (18) Custom Connect CDL Link - Diverse Route with Company Electronics - OC3c

<u>Jurisdiction</u>	<u>Nonrecurring Charge</u>	<u>One Year Monthly Rate</u>	<u>Three Year Monthly Rate</u> <sup>[1]</sup>	<u>Five Year Monthly Rate</u> <sup>[1]</sup>	<u>Seven Year Monthly Rate</u> <sup>[1]</sup>
Alabama#	\$315.00	\$8,944.00	\$5,415.00	\$4,855.00	\$4,365.00
Missouri	\$6,000.00	\$5,102.50	\$3,650.00	\$3,525.00	\$3,400.00

## (19) Custom Connect CDL Link - Diverse Route with Company Electronics - OC12

<u>Jurisdiction</u>	<u>Nonrecurring Charge</u>	<u>One Year Monthly Rate</u>	<u>Three Year Monthly Rate</u> <sup>[1]</sup>	<u>Five Year Monthly Rate</u> <sup>[1]</sup>	<u>Seven Year Monthly Rate</u> <sup>[1]</sup>
Alabama#	\$315.00	\$8,190.00	\$4,875.00	\$4,350.00	\$3,900.00
Missouri	\$6,000.00	\$4,127.50	\$2,900.00	\$2,775.00	\$2,650.00

# Rates applicable for special access only.

[1] Effective March 1, 2022 Custom Connect with terms of 36, 60 or 84 months will be grandfathered until the expiration date of the current term. As of this effective date, 36, 60 and 84 month term renewals will not be offered on this plan. Upon expiration of the current term, rates will revert to month-to-month/one year.

Effective: October 4, 2022

Original Page 20-21

## FACILITIES FOR INTERSTATE ACCESS

20. Optical Networking  
20.9 Rates and Charges (Cont'd)

## (20) Custom Connect CDL Link - Diverse Route without Company Electronics - OC12

	<u>Nonrecurring Charge</u>	<u>One Year Monthly Rate</u>	<u>Three Year Monthly Rate</u> <sup>[1]</sup>	<u>Five Year Monthly Rate</u> <sup>[1]</sup>	<u>Seven Year Monthly Rate</u> <sup>[1]</sup>
<u>Jurisdiction</u>					
Alabama#	\$315.00	\$6,480.50	\$3,850.00	\$3,440.00	\$3,080.00
Missouri	\$3,000.00	\$1,560.00	\$1,165.00	\$1,125.00	\$1,100.00

## (21) Custom Connect CDL Link - Diverse Route with Company Electronics - OC12c

	<u>Nonrecurring Charge</u>	<u>One Year Monthly Rate</u>	<u>Three Year Monthly Rate</u> <sup>[1]</sup>	<u>Five Year Monthly Rate</u> <sup>[1]</sup>	<u>Seven Year Monthly Rate</u> <sup>[1]</sup>
<u>Jurisdiction</u>					
Alabama#	\$315.00	\$20,858.50	\$14,005.00	\$12,795.00	\$11,725.00
Missouri	\$6,000.00	\$9,555.00	\$7,050.00	\$6,825.00	\$6,625.00

## (22) Custom Connect CDL Link - Diverse Route with Company Electronics – OC48

	<u>Nonrecurring Charge</u>	<u>One Year Monthly Rate</u>	<u>Three Year Monthly Rate</u> <sup>[1]</sup>	<u>Five Year Monthly Rate</u> <sup>[1]</sup>	<u>Seven Year Monthly Rate</u> <sup>[1]</sup>
<u>Jurisdiction</u>					
Alabama#	\$315.00	\$19,844.50	\$13,275.00	\$12,120.00	\$11,100.00
Missouri	\$6,000.00	\$6,630.00	\$4,975.00	\$4,680.00	\$4,550.00

# Rates applicable for special access only.

[1] Effective March 1, 2022 Custom Connect with terms of 36, 60 or 84 months will be grandfathered until the expiration date of the current term. As of this effective date, 36, 60 and 84 month term renewals will not be offered on this plan. Upon expiration of the current term, rates will revert to month-to-month/one year.

Effective: October 4, 2022

Original Page 20-22

## FACILITIES FOR INTERSTATE ACCESS

20. Optical Networking  
20.9 Rates and Charges (Cont'd)

## (23) Custom Connect CDL Link - Diverse Route without Company Electronics - OC48

	<u>Nonrecurring Charge</u>	<u>One Year Monthly Rate</u>	<u>Three Year Monthly Rate</u> <sup>[1]</sup>	<u>Five Year Monthly Rate</u> <sup>[1]</sup>	<u>Seven Year Monthly Rate</u> <sup>[1]</sup>
<u>Jurisdiction</u>					
Alabama#	\$315.00	\$12,883.00	\$8,620.00	\$7,870.00	\$7,210.00
Missouri	\$3,000.00	\$1,560.00	\$1,100.00	\$1,025.00	\$975.00

## (24) Custom Connect CDL Link - Diverse Route with Company Electronics – OC48c

	<u>Nonrecurring Charge</u>	<u>One Year Monthly Rate</u>	<u>Three Year Monthly Rate</u> <sup>[1]</sup>	<u>Five Year Monthly Rate</u> <sup>[1]</sup>	<u>Seven Year Monthly Rate</u> <sup>[1]</sup>
<u>Jurisdiction</u>					
Alabama#	\$315.00	\$53,254.50	\$36,150.00	\$33,773.00	\$31,590.00
Missouri	\$6,000.00	\$17,160.00	\$13,000.00	\$12,500.00	\$12,250.00

(25) Custom Connect CDL Link - Diverse Route with Company Electronics – OC192<sup>(1)</sup>

	<u>Nonrecurring Charge</u>	<u>One Year Monthly Rate</u>	<u>Three Year Monthly Rate</u> <sup>[1]</sup>	<u>Five Year Monthly Rate</u> <sup>[1]</sup>	<u>Seven Year Monthly Rate</u> <sup>[1]</sup>
<u>Jurisdiction</u>					
Alabama#	\$315.00	\$48,067.50	\$36,150.00	\$33,775.00	\$31,590.00
Missouri	\$12,000.00	\$18,882.50	\$13,200.00	\$12,550.00	\$11,875.00

# Rates applicable for special access only.

[1] Effective March 1, 2022 Custom Connect with terms of 36, 60 or 84 months will be grandfathered until the expiration date of the current term. As of this effective date, 36, 60 and 84 month term renewals will not be offered on this plan. Upon expiration of the current term, rates will revert to month-to-month/one year. CUSTOM CONNECT OC-192 Point-to-Point configurations are grandfathered as of February 11, 2019 and will no longer be available for new service requests. This does not impact CUSTOM CONNECT OC-192 Multipoint or Ring configurations.

Effective: October 4, 2022

Original Page 20-23

## FACILITIES FOR INTERSTATE ACCESS

20. Optical Networking  
20.9 Rates and Charges (Cont'd)(26) Custom Connect CDL Link - Diverse Route without Company Electronics – OC192 <sup>[1]</sup>

	<u>Nonrecurring Charge</u>	<u>One Year Monthly Rate</u>	<u>Three Year Monthly Rate</u> <sup>[1]</sup>	<u>Five Year Monthly Rate</u> <sup>[1]</sup>	<u>Seven Year Monthly Rate</u> <sup>[1]</sup>
<u>Jurisdiction</u>					
Alabama#	\$315.00	\$25,525.50	\$19,220.00	\$17,960.00	\$16,825.00
Missouri	\$3,000.00	\$5,460.00	\$3,925.00	\$3,725.00	\$3,600.00

## (27) Custom Connect CDL Link - Ring Route with Company Electronics - OC3

	<u>Nonrecurring Charge</u>	<u>One Year Monthly Rate</u>	<u>Three Year Monthly Rate</u> <sup>[1]</sup>	<u>Five Year Monthly Rate</u> <sup>[1]</sup>	<u>Seven Year Monthly Rate</u> <sup>[1]</sup>
<u>Jurisdiction</u>					
Alabama#	\$315.00	\$8,970.00	\$5,120.00	\$4,510.00	\$4,000.00
Missouri	\$3,000.00	\$3,276.00	\$2,450.00	\$2,400.00	\$2,350.00

## (28) Custom Connect CDL Link - Ring Route without Company Electronics - OC3

	<u>Nonrecurring Charge</u>	<u>One Year Monthly Rate</u>	<u>Three Year Monthly Rate</u> <sup>[1]</sup>	<u>Five Year Monthly Rate</u> <sup>[1]</sup>	<u>Seven Year Monthly Rate</u> <sup>[1]</sup>
<u>Jurisdiction</u>					
Alabama#	\$315.00	\$6,136.00	\$3,500.00	\$3,080.00	\$2,740.00
Missouri	\$3,000.00	\$2,658.50	\$2,020.00	\$1,995.00	\$1,970.00

# Rates applicable for special access only.

[1] Effective March 1, 2022 Custom Connect with terms of 36, 60 or 84 months will be grandfathered until the expiration date of the current term. As of this effective date, 36, 60 and 84 month term renewals will not be offered on this plan. Upon expiration of the current term, rates will revert to month-to-month/one year. CUSTOM CONNECT OC-192 Point-to-Point configurations are grandfathered as of February 11, 2019 and will no longer be available for new service requests. This does not impact CUSTOM CONNECT OC-192 Multipoint or Ring configurations.

Effective: October 4, 2022

Original Page 20-24

## FACILITIES FOR INTERSTATE ACCESS

20. Optical Networking  
20.9 Rates and Charges (Cont'd)

## (29) Custom Connect CDL Link - Ring Route with Company Electronics - OC12

	<u>Nonrecurring Charge</u>	<u>One Year Monthly Rate</u>	<u>Three Year Monthly Rate</u> <sup>[1]</sup>	<u>Five Year Monthly Rate</u> <sup>[1]</sup>	<u>Seven Year Monthly Rate</u> <sup>[1]</sup>
<u>Jurisdiction</u>					
Alabama#	\$315.00	\$10,920.00	\$6,500.00	\$5,800.00	\$5,200.00
Missouri	\$6,000.00	\$5,135.00	\$3,800.00	\$3,650.00	\$3,475.00

## (30) Custom Connect CDL Link - Ring Route without Company Electronics - OC12

	<u>Nonrecurring Charge</u>	<u>One Year Monthly Rate</u>	<u>Three Year Monthly Rate</u> <sup>[1]</sup>	<u>Five Year Monthly Rate</u> <sup>[1]</sup>	<u>Seven Year Monthly Rate</u> <sup>[1]</sup>
<u>Jurisdiction</u>					
Alabama#	\$315.00	\$7,202.00	\$4,280.00	\$3,820.00	\$3,420.00
Missouri	\$3,000.00	\$2,658.50	\$2,020.00	\$1,995.00	\$1,970.00

## (31) Custom Connect CDL Link - Ring Route with Company Electronics - OC48

	<u>Nonrecurring Charge</u>	<u>One Year Monthly Rate</u>	<u>Three Year Monthly Rate</u> <sup>[1]</sup>	<u>Five Year Monthly Rate</u> <sup>[1]</sup>	<u>Seven Year Monthly Rate</u> <sup>[1]</sup>
<u>Jurisdiction</u>					
Alabama#	\$315.00	\$26,455.00	\$17,700.00	\$16,160.00	\$14,800.00
Missouri	\$6,000.00	\$7,475.00	\$5,500.00	\$5,250.00	\$5,000.00

## (32) Custom Connect CDL Link - Ring Route without Company Electronics - OC48

	<u>Nonrecurring Charge</u>	<u>One Year Monthly Rate</u>	<u>Three Year Monthly Rate</u> <sup>[1]</sup>	<u>Five Year Monthly Rate</u> <sup>[1]</sup>	<u>Seven Year Monthly Rate</u> <sup>[1]</sup>
<u>Jurisdiction</u>					
Alabama#	\$315.00	\$15,158.00	\$10,140.00	\$9,260.00	\$8,480.00
Missouri	\$3,000.00	\$2,658.50	\$2,020.00	\$1,995.00	\$1,970.00

# Rates applicable for special access only.

[1] Effective March 1, 2022 Custom Connect with terms of 36, 60 or 84 months will be grandfathered until the expiration date of the current term. As of this effective date, 36, 60 and 84 month term renewals will not be offered on this plan. Upon expiration of the current term, rates will revert to month-to-month/one year.



FACILITIES FOR INTERSTATE ACCESS

20. Optical Networking  
 20.9 Rates and Charges (Cont'd)

(33) Custom Connect CDL Link - Ring Route with Company Electronics – OC192

<u>Jurisdiction</u>	<u>Nonrecurring Charge</u>	<u>One Year Monthly Rate</u>	<u>Three Year Monthly Rate</u> <sup>[1]</sup>	<u>Five Year Monthly Rate</u> <sup>[1]</sup>	<u>Seven Year Monthly Rate</u> <sup>[1]</sup>
Alabama#	\$315.00	\$64,090.00	\$48,200.00	\$45,030.00	\$42,120.00
Missouri	\$12,000.00	\$20,312.50	\$14,900.00	\$14,050.00	\$13,500.00

(34) Custom Connect CDL Link - Ring Route without Company Electronics – OC192

<u>Jurisdiction</u>	<u>Nonrecurring Charge</u>	<u>One Year Monthly Rate</u>	<u>Three Year Monthly Rate</u> <sup>[1]</sup>	<u>Five Year Monthly Rate</u> <sup>[1]</sup>	<u>Seven Year Monthly Rate</u> <sup>[1]</sup>
Alabama#	\$315.00	\$31,902.00	\$24,020.00	\$22,450.00	\$21,030.00
Missouri	\$3,000.00	\$6,825.00	\$4,900.00	\$4,650.00	\$4,500.00

(35) Custom Connect - Rider - DS1

<u>Jurisdiction</u>	<u>Monthly Rate</u> <sup>[1]</sup>
Alabama#	\$65.00
Missouri	\$97.50

(36) Custom Connect - Rider – DS3

<u>Jurisdiction</u>	<u>Monthly Rate</u> <sup>[1]</sup>
Alabama#	\$175.50
Missouri	\$325.00

# Rates applicable for special access only.

[1] Effective March 1, 2022 Custom Connect with terms of 36, 60 or 84 months will be grandfathered until the expiration date of the current term. As of this effective date, 36, 60 and 84 month term renewals will not be offered on this plan. Upon expiration of the current term, rates will revert to month-to-month/one year.

Effective: October 4, 2022

Original Page 20-26

## FACILITIES FOR INTERSTATE ACCESS

20. Optical Networking20.9 Rates and Charges (Cont'd)

## (37) Custom Connect - Rider – STS1

<u>Jurisdiction</u>	<u>Monthly Rate</u> <sup>[1]</sup>
Alabama#	\$175.50
Missouri	\$312.00

## (38) Custom Connect - Rider – OC3

<u>Jurisdiction</u>	
Alabama#	\$474.50
Missouri	\$975.00

## (39) Custom Connect - Rider – OC12

<u>Jurisdiction</u>	
Alabama#	\$1,280.50
Missouri	\$2,925.00

## (40) Custom Connect - Rider – OC48

<u>Jurisdiction</u>	
Alabama#	\$3,458.00
Missouri	\$5,850.00

## (41) Custom Connect - Rider – 10M

<u>Jurisdiction</u>	
Alabama#	\$135.00
Missouri	\$250.00

# Rates applicable for special access only.

[1] Effective March 1, 2022 Custom Connect with terms of 36, 60 or 84 months will be grandfathered until the expiration date of the current term. As of this effective date, 36, 60 and 84 month term renewals will not be offered on this plan. Upon expiration of the current term, rates will revert to month-to-month/one year.

Effective: October 4, 2022

Original Page 20-27

## FACILITIES FOR INTERSTATE ACCESS

20. Optical Networking  
20.9 Rates and Charges (Cont'd)

	<u>Monthly Rate</u> <sup>[1]</sup>
(42) Custom Connect - Rider – 20M	
<u>Jurisdiction</u>	
Alabama#	\$150.00
Missouri	\$275.00
(43) Custom Connect - Rider – 50M	
<u>Jurisdiction</u>	
Alabama#	\$270.00
Missouri	\$500.00
(44) Custom Connect - Rider – 100M	
<u>Jurisdiction</u>	
Alabama#	\$300.00
Missouri	\$550.00
(45) Custom Connect - Rider – 150M	
<u>Jurisdiction</u>	
Alabama#	\$365.00
Missouri	\$675.00
(46) Custom Connect - Rider – 300M	
<u>Jurisdiction</u>	
Alabama#	\$730.00
Missouri	\$1,350.00

# Rates applicable for special access only.

[1] Effective March 1, 2022 Custom Connect with terms of 36, 60 or 84 months will be grandfathered until the expiration date of the current term. As of this effective date, 36, 60 and 84 month term renewals will not be offered on this plan. Upon expiration of the current term, rates will revert to month-to-month/one year.

FACILITIES FOR INTERSTATE ACCESS

20. Optical Networking  
 20.9 Rates and Charges (Cont'd)

	<u>Monthly Rate</u> <sup>[1]</sup>
(47) Custom Connect - Rider – 450M	
<u>Jurisdiction</u>	
Alabama#	\$985.00
Missouri	\$1,825.00
(48) Custom Connect - Rider – 600M	
<u>Jurisdiction</u>	
Alabama#	\$1,085.00
Missouri	\$2,010.00
(49) Custom Connect - Rider – 1G	
<u>Jurisdiction</u>	
Alabama#	\$1,970.00
Missouri	\$3,650.00
(50) Custom Connect - Shared Transport – DS1	
	<u>Per Mile</u>
	<u>Monthly Rate</u> <sup>[1]</sup>
<u>Jurisdiction</u>	
Alabama#	\$91.00
Missouri	\$15.60

# Rates applicable for special access only.

[1] Effective March 1, 2022 Custom Connect with terms of 36, 60 or 84 months will be grandfathered until the expiration date of the current term. As of this effective date, 36, 60 and 84 month term renewals will not be offered on this plan. Upon expiration of the current term, rates will revert to month-to-month/one year.

Effective: October 4, 2022

Original Page 20-29

## FACILITIES FOR INTERSTATE ACCESS

20. Optical Networking20.9 Rates and Charges (Cont'd)

## (51) Custom Connect - Shared Transport – DS3/STS1

<u>Jurisdiction</u>	<u>Per Mile Monthly Rate</u> <sup>[1]</sup>
Alabama#	\$234.00
Missouri	\$136.50

## (52) Custom Connect - Shared Transport – OC3/OC3c

<u>Jurisdiction</u>	<u>Per Mile Monthly Rate</u> <sup>[1]</sup>
Alabama#	\$520.00
Missouri	\$273.00

## (53) Custom Connect - Shared Transport - OC12/OC12c

<u>Jurisdiction</u>	<u>Per Mile Monthly Rate</u> <sup>[1]</sup>
Alabama#	\$1,300.00
Missouri	\$585.00

## (54) Custom Connect - Shared Transport – OC48/OC48c

<u>Jurisdiction</u>	<u>Per Mile Monthly Rate</u> <sup>[1]</sup>
Alabama#	\$4,225.00
Missouri	\$1,462.50

# Rates applicable for special access only.

[1] Effective March 1, 2022 Custom Connect with terms of 36, 60 or 84 months will be grandfathered until the expiration date of the current term. As of this effective date, 36, 60 and 84 month term renewals will not be offered on this plan. Upon expiration of the current term, rates will revert to month-to-month.

Effective: October 4, 2022

Original Page 20-30

## FACILITIES FOR INTERSTATE ACCESS

20. Optical Networking20.9 Rates and Charges (Cont'd)

## (55) Custom Connect – Dedicated Transport - OC3/OC3c

<u>Jurisdiction</u>	<u>Per Mile Monthly Rate</u> <sup>[1]</sup>
Alabama#	\$390.00
Missouri	\$221.00

## (56) Custom Connect - Dedicated Transport - OC12/OC12c

<u>Jurisdiction</u>	<u>Per Mile Monthly Rate</u> <sup>[1]</sup>
Alabama#	\$871.00
Missouri	\$312.00

## (57) Custom Connect – Dedicated Transport - OC48/OC48c

<u>Jurisdiction</u>	<u>Per Mile Monthly Rate</u> <sup>[1]</sup>
Alabama#	\$2,847.00
Missouri	\$674.70

(58) Custom Connect – Dedicated Transport – OC192 <sup>(1)</sup>

<u>Jurisdiction</u>	<u>Per Mile Monthly Rate</u> <sup>[1]</sup>
Alabama#	\$9,308.00
Missouri	\$1,462.50

# Rates applicable for special access only.

[1] Effective March 1, 2022 Custom Connect with terms of 36, 60 or 84 months will be grandfathered until the expiration date of the current term. As of this effective date, 36, 60 and 84 month term renewals will not be offered on this plan. Upon expiration of the current term, rates will revert to month-to-month/one year. CUSTOM CONNECT OC-192 Point-to-Point configurations are grandfathered as of February 11, 2019 and will no longer be available for new service requests. This does not impact CUSTOM CONNECT OC-192 Multipoint or Ring configurations.

Effective: October 4, 2022

Original Page 20-31

## FACILITIES FOR INTERSTATE ACCESS

20. Optical Networking20.9 Rates and Charges (Cont'd)

## (59) Custom Connect – Regeneration Charge – OC3

<u>Jurisdiction</u>	<u>One Year Monthly Rate</u>	<u>Three Year Monthly Rate</u> <sup>[1]</sup>	<u>Five Year Monthly Rate</u> <sup>[1]</sup>	<u>Seven Year Monthly Rate</u> <sup>[1]</sup>
Alabama#	\$2,470.00	\$1,500.00	\$1,300.00	\$1,125.00
Missouri	\$2,470.00	\$1,500.00	\$1,300.00	\$1,125.00

## (60) Custom Connect – Regeneration Charge – OC12

<u>Jurisdiction</u>	<u>One Year Monthly Rate</u>	<u>Three Year Monthly Rate</u> <sup>[1]</sup>	<u>Five Year Monthly Rate</u> <sup>[1]</sup>	<u>Seven Year Monthly Rate</u> <sup>[1]</sup>
Alabama#	\$4,225.00	\$2,600.00	\$2,300.00	\$2,035.00
Missouri	\$4,225.00	\$2,600.00	\$2,300.00	\$2,035.00

## (61) Custom Connect – Regeneration Charge – OC48

<u>Jurisdiction</u>	<u>One Year Monthly Rate</u>	<u>Three Year Monthly Rate</u> <sup>[1]</sup>	<u>Five Year Monthly Rate</u> <sup>[1]</sup>	<u>Seven Year Monthly Rate</u> <sup>[1]</sup>
Alabama#	\$6,240.00	\$4,600.00	\$4,400.00	\$4,210.00
Missouri	\$6,240.00	\$4,600.00	\$4,400.00	\$4,210.00

(62) Custom Connect – Regeneration Charge – OC192<sup>(1)</sup>

<u>Jurisdiction</u>	<u>One Year Monthly Rate</u>	<u>Three Year Monthly Rate</u> <sup>[1]</sup>	<u>Five Year Monthly Rate</u> <sup>[1]</sup>	<u>Seven Year Monthly Rate</u> <sup>[1]</sup>
Alabama#	\$9,425.00	\$6,875.00	\$6,250.00	\$5,680.00
Missouri	\$9,425.00	\$6,875.00	\$6,250.00	\$5,680.00

# Rates applicable for special access only.

[1] Effective March 1, 2022 Custom Connect with terms of 36, 60 or 84 months will be grandfathered until the expiration date of the current term. As of this effective date, 36, 60 and 84 month term renewals will not be offered on this plan. Upon expiration of the current term, rates will revert to month-to-month/one year. CUSTOM CONNECT OC-192 Point-to-Point configurations are grandfathered as of February 11, 2019 and will no longer be available for new service requests. This does not impact CUSTOM CONNECT OC-192 Multipoint or Ring configurations.

FACILITIES FOR INTERSTATE ACCESS

20. Optical Networking  
 20.9 Rates and Charges (Cont'd)

(63) Capacity Reconfiguration Charge – per STS1/DS3 equivalent

<u>Jurisdiction</u>	<u>Non-Recurring Charge</u> <sup>[1]</sup>
Alabama#	\$625.00
Missouri	\$625.00

# Rates applicable for special access only.

[1] Effective March 1, 2022 Custom Connect with terms of 36, 60 or 84 months will be grandfathered until the expiration date of the current term. As of this effective date, 36, 60 and 84 month term renewals will not be offered on this plan. Upon expiration of the current term, rates will revert to month-to-month/one year.